

MRE series

1,000kg / 1,200kg / 1,400kg

Tilting Mast Reach Truck



- Complete AC infrastructure on drive, hoist and steering motors
- 180° and 360° steering at the touch of a button
- AccuTouch™ mini-lever module or joystick controls
- Vehicle Control Manager - VCM
- Dual CANbus wiring

VDI 2198 – General Specifications MR10E, MR12E, MR14E

			Yale	Yale	Yale
Distinguishing mark	1.1	Manufacturer (abbreviation)		Yale	Yale
	1.2	Manufacturer's type designation		MR10E	MR12E
	1.3	Drive: electric (battery or mains), diesel, petrol, fuel gas		Electric (battery)	Electric (battery)
	1.4	Operator type: hand, pedestrian, standing, seated, order-picker		Seated	Seated
	1.5	Rated capacity/Rated load	Q (t)	1.0	1.2
	1.6	Load centre distance	c (mm)	600	600
	1.8	Load distance, centre of drive axle to fork	x (mm)	181	181
	1.9	Wheelbase	y (mm)	1300	1300
	1.9	Wheelbase			1400
Weights	2.1	Service weight	kg	2845	2845
	2.3	Axle loading, unladen front/rear ⁽⁵⁾	kg	1622 / 1223	1622 / 1223
	2.4	Axle loading fork advanced, laden front/rear	kg	810 / 3035	695 / 3350
	2.5	Axle loading fork retracted, laden front/rear	kg	1288 / 2557	1222 / 2823
	2.5	Axle loading fork retracted, laden front/rear			1605 / 2743
Tyres/chassis	3.1	Tyres: polyurethane, tophane, vulkollan, front/rear		Vulkollan / Vulkollan	Vulkollan / Vulkollan
	3.2	Tyre size, front	ø (mm x mm)	305 x 140	305 x 140
	3.3	Tyre size, rear	ø (mm x mm)	220 x 85	220 x 85
	3.5	Wheels, number front/rear (x = driven wheels)		1 x / 2	1 x / 2
	3.7	Tread, rear	b ₁₁ (mm)	990	990
	3.7	Tread, rear			1155
	3.7	Tread, rear			1155
Dimensions	4.1	Tilt of mast/fork carriage forward/backward	α / β (°)	1 / 3	1 / 3
	4.2	Height of mast, lowered	h ₁ (mm)	2191	2191
	4.3	Free lift	h ₂ (mm)	1706	1706
	4.4	Lift	h ₃ (mm)	5000	5000
	4.5	Height, mast extended ⁽¹⁾	h ₄ (mm)	5560	5560
	4.7	Height of overhead guard (cabin) ⁽²⁾	h ₆ (mm)	2175	2175
	4.8	Seat height relating to SIP	h ₇ (mm)	1082	1082
	4.10	Height of wheel arms	h ₈ (mm)	235	235
	4.19	Overall length	l ₁ (mm)	2500	2500
	4.20	Length to face of forks	l ₂ (mm)	1350	1350
	4.21	Overall width ⁽³⁾	b ₁ /b ₂ (mm)	1125	1125
	4.22	Fork dimensions DIN ISO 2331	s/e/l (mm)	40 / 80 / 1150	40 / 80 / 1150
	4.23	Fork carriage ISO 2328, class/type A, B		2A	2A
	4.24	Fork-carriage width	b ₃ (mm)	700	700
	4.25	Distance between fork-arms min./max. ⁽⁷⁾	b ₅ (mm)	220 / 640	220 / 640
	4.26	Distance between wheel arms/loading surfaces	b ₄ (mm)	900	900
	4.28	Reach distance	l ₄ (mm)	341	341
	4.31	Ground clearance, laden, below mast	m ₁ (mm)	75	75
	4.32	Ground clearance, centre of wheelbase	m ₂ (mm)	75 ⁽⁸⁾	75 ⁽⁸⁾
	4.34.1	Aisle width for pallets 1000mm x 1200mm crossways	A _{st} (mm)	2770	2770
	4.34.2	Aisle width for pallets 800mm x 1200mm lengthwise	A _{st} (mm)	2850	2850
	4.35	Turning radius	W _a (mm)	1555	1555
	4.37	Length across wheel arms	l ₇ (mm)	1660	1660
4.42	Step height (from ground to running board)	mm	550	550	
4.43	Step height (between intermediate steps between running board and floor)	mm	371	371	
Performance data	5.1	Travel speed, laden/unladen	km/h	11 / 11	11 / 11
	5.1.1	Travel speed, laden/unladen, backwards	km/h	11 / 11	11 / 11
	5.2	Lift speed, laden/unladen	m/s	0.45 / 0.70	0.40 / 0.70
	5.3	Lowering speed, laden/unladen	m/s	0.55 / 0.45	0.55 / 0.45
	5.4	Reaching speed, laden/unladen	m/s	0.15 / 0.15	0.15 / 0.15
	5.7	Gradeability, laden/unladen	%	9.0 / 12.7	8.5 / 12.7
	5.8	Max. gradeability laden/unladen	%	14.6 / 20.2	13,8 / 20.2
	5.9	Acceleration time laden/unladen	s	5.5 / 4.9	5.6 / 4.9
	5.10	Service brake		Electric	Electric
	5.10	Service brake			Electric
Electric engine	6.1	Drive motor S2 60 minute rating	kW	5.4	5.4
	6.2	Lift motor, S3 15% rating	kW	9.9	9.9
	6.3	Battery according to DIN 43531/35 /36 A,B,C, no		B	B
	6.4	Battery voltage/nominal capacity K5	(V)/(Ah)	48 / 560 ⁽⁶⁾	48 / 560 ⁽⁶⁾
	6.5	Battery weight ⁽⁴⁾	kg	937	937
	6.6	Energy consumption according to VDI cycle	kWh/h @ no. of cycles	2.9	3.4
8.1	Type of drive unit		AC-Controller	AC-Controller	
10.7	Sound pressure level at the driver's seat	dB (A)	69.55	69.55	

⁽¹⁾ With load backrest 1000mm height, h₄ + 508mm; with load backrest 1500mm height, h₄ + 1008mm

⁽²⁾ With beacon h₆ + 120mm. ; With OHG Grid Protector h₆ + 20mm ; With OHG Screen Protector h₆ + 30mm.

⁽³⁾ With load wheels lateral covers: 1289mm (MR14E).

⁽⁴⁾ These values may vary of +/- 5%.

⁽⁵⁾ Forks retracted.

⁽⁶⁾ See "Batteries table".

⁽⁷⁾ Side shift stroke is +/-75mm.

⁽⁸⁾ With side rollers options: 10mm

All values are nominal values and they are subject to tolerances.

For further information, please contact the manufacturer.

Yale products might be subject to change without notice.

Lift trucks illustrated may feature optional equipment.

Values may vary with alternative configurations.

Truck Dimensions

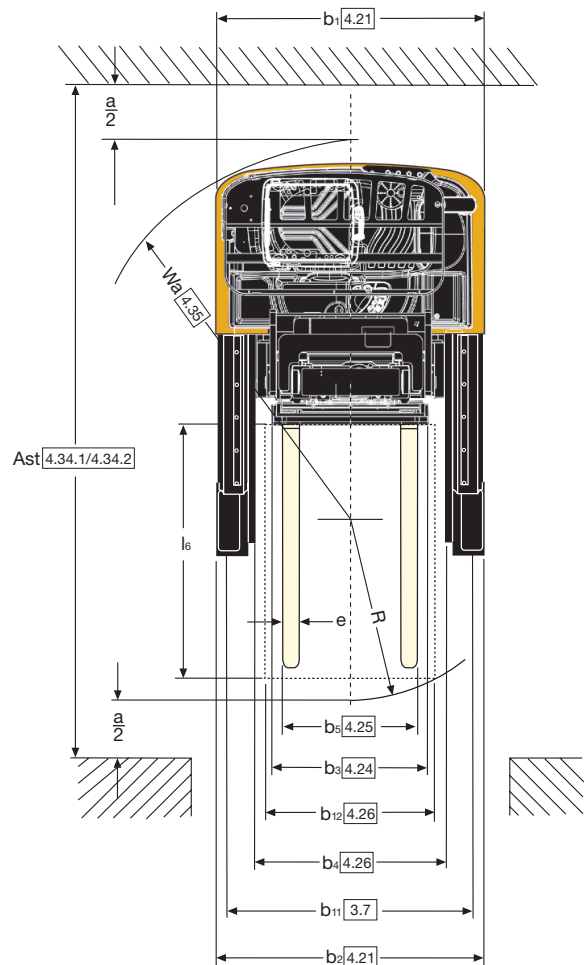
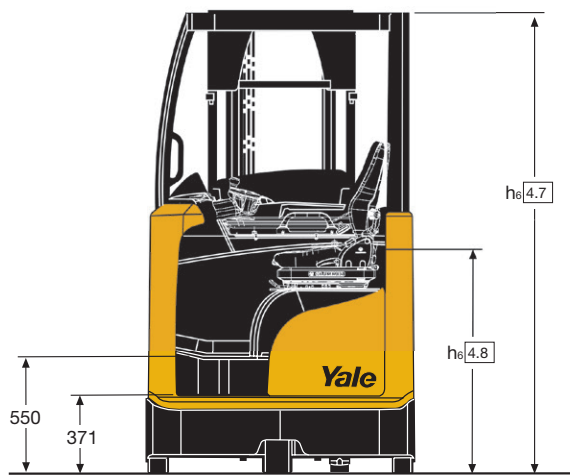
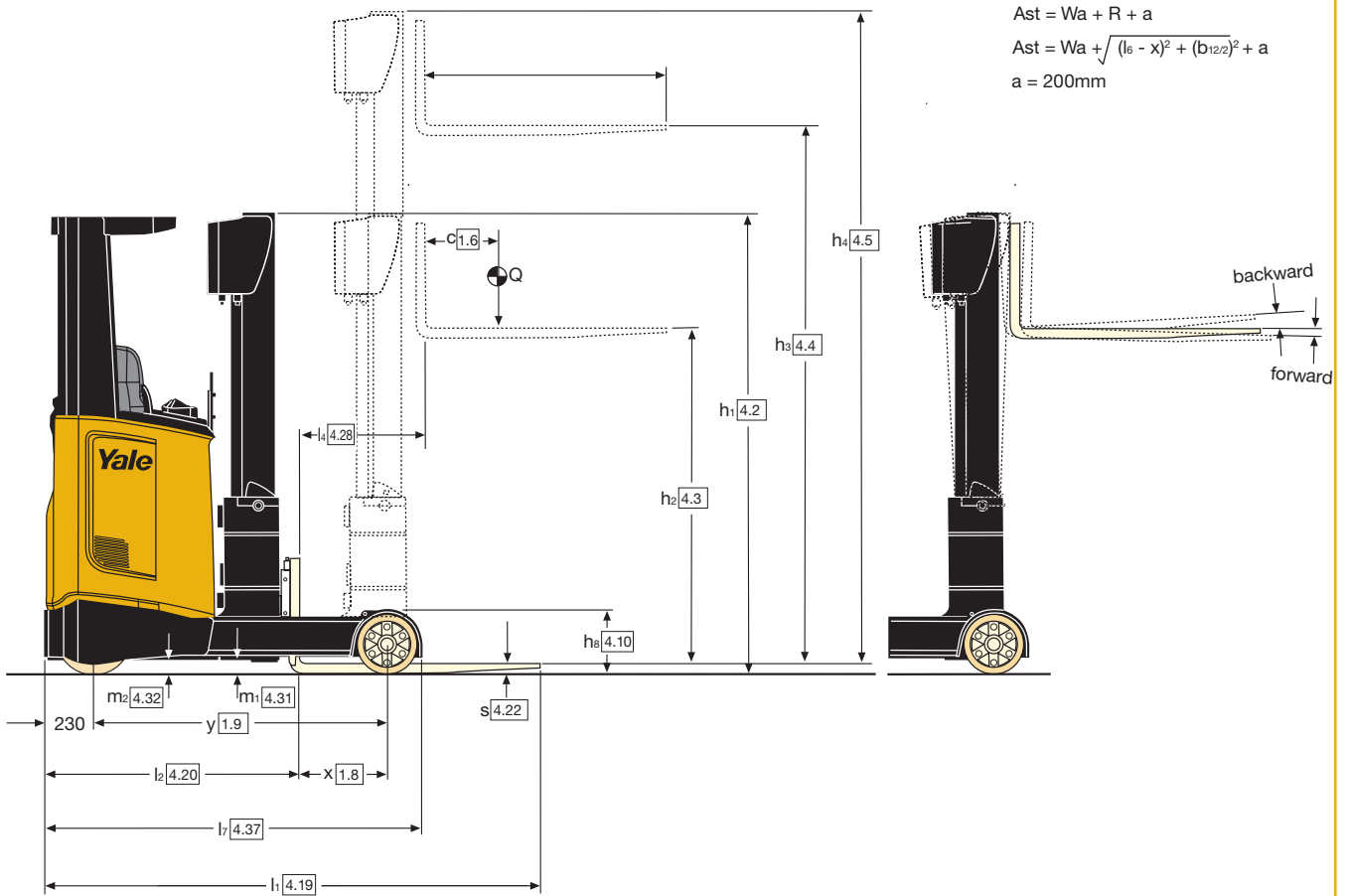

MR10E, MR12E truck dimensions for batteries

Distinguishing mark	1.2	Manufacturer's type designation	MR10E						
			1.8	Load distance, centre of drive axle to fork	x (mm)	361	361	271	271
1.9	Wheelbase	y (mm)	1300	1300	1300	1300	1300	1300	
Weights	2.1	Service weight	kg	2389	2389	2602	2602	2845	2845
	2.3	Axle loading, unladen front/rear ⁽²⁾	kg	1522 / 867	1522 / 867	1571 / 1031	1571 / 1031	1622 / 1223	1622 / 1223
	2.4	Axle loading fork advanced, laden front/rear (MR10E)	kg	577 / 2812	577 / 2812	693 / 2909	693 / 2909	810 / 3035	810 / 3035
	2.4	Axle loading fork advanced, laden front/rear (MR12E)	kg	462 / 3127	462 / 3127	577 / 3225	577 / 3225	695 / 3350	695 / 3350
	2.5	Axle loading fork retracted, laden front/rear (MR10E)	kg	1327 / 2062	1327 / 2062	1306 / 2296	1306 / 2296	1288 / 2557	1288 / 2557
2.5	Axle loading fork retracted, laden front/rear (MR12E)	kg	1288 / 2301	1288 / 2301	1254 / 2548	1254 / 2548	1222 / 2823	1222 / 2823	
Dimensions	4.19	Overall length	l ₁ (mm)	2320	2320	2410	2410	2500	2500
	4.20	Length to face of forks	l ₂ (mm)	1170	1170	1260	1260	1350	1350
	4.28	Reach distance	l ₄ (mm)	521	521	431	431	341	341
	4.34.1	Aisle width for pallets 1000mm x 1200mm crossways	A _{st} (mm)	2632	2632	2700	2700	2770	2770
	4.34.2	Aisle width for pallets 800mm x 1200mm lengthways	A _{st} (mm)	2685	2685	2766	2766	2850	2850
4.35	Turning radius	W _a (mm)	1555	1555	1555	1555	1555	1555	
Electric engine	6.3	Battery according to DIN 43531/35 /36 A, B, C, no		B	B	B	B	B	B
	6.4	Battery voltage/nominal capacity K5	(V) / (Ah)	48 / 280	48 / 310	48 / 420	48 / 465	48 / 560	48 / 620
	6.5	Battery weight ⁽¹⁾	kg	541	543	746	750	937	945

⁽¹⁾ These values may vary of +/- 5%. ⁽²⁾ Forks retracted. All weights (2.1 to 2.5) are with lowest mast and standard forks.

MR14E truck dimensions for batteries

Distinguishing mark	1.2	Manufacturer's type designation	MR14E				
			1.8	Load distance, centre of drive axle to fork	x (mm)	443	443
1.9	Wheelbase	y (mm)	1400	1400	1400	1400	
Weights	2.1	Service weight	kg	2716	2716	2948	2948
	2.3	Axle loading, unladen front/rear ⁽²⁾	kg	1758 / 958	1758 / 958	1851 / 1097	1851 / 1097
	2.4	Axle loading fork advanced, laden front/rear	kg	562 / 3554	562 / 3554	694 / 3654	694 / 3654
	2.5	Axle loading fork retracted, laden front/rear	kg	1568 / 2548	1568 / 2548	1605 / 2743	1605 / 2743
Dimensions	4.19	Overall length	l ₁ (mm)	2351	2351	2423	2423
	4.20	Length to face of forks	l ₂ (mm)	1205	1205	1277	1277
	4.28	Reach distance	l ₄ (mm)	617	617	545	545
	4.34.1	Aisle width for pallets 1000mm x 1200mm crossways	A _{st} (mm)	2702	2702	2741	2741
	4.34.2	Aisle width for pallets 800mm x 1200mm lengthways	A _{st} (mm)	2743	2743	2792	2792
4.35	Turning radius	W _a (mm)	1672	1672	1672	1672	
Electric engine	6.3	Battery according to DIN 43531/35 /36 A, B, C, no		C	C	C	C
	6.4	Battery voltage/nominal capacity K5	(V) / (Ah)	48 / 420	48 / 465	48 / 560	48 / 620
	6.5	Battery weight ⁽¹⁾	kg	750	750	939	950

⁽¹⁾ These values may vary of +/- 5%.

⁽²⁾ Forks retracted.

All weights (2.1 to 2.5) are with lowest mast and standard forks.

All values are nominal values and they are subject to tolerances. For further information, please contact the manufacturer.

Yale products might be subject to change without notice. Lift trucks illustrated may feature optional equipment.

Values may vary with alternative configurations.

MR10E, MR12E, MR14E - Mast details, 3 stage full free lift (B708)

Model	Tilt α / β	Lift (h ₃) mm	Free lift (h ₂) mm	Height of mast lowered (h ₁) mm	Height of mast extended (h ₄) ⁽¹⁾ mm
MR10E	1 / 3	5000	1706	2191	5560
	1 / 3	5250	1792	2277	5810
	1 / 3	5500	1878	2363	6060
	1 / 3	5750	1964	2449	6310
	1 / 3	6000	2050	2535	6560
MR12E	1 / 3	6250	2136	2621	6810
MR14E	0.5 / 1	6500	2222	2707	7060
	0.5 / 1	6750	2308	2793	7310
	0.5 / 1	7000	2394	2879	7560
	0.5 / 1	7250	2480	2965	7810
	0.5 / 1	7500	2566	3051	8060

⁽¹⁾ With load backrest 1000mm height, h₄ + 508mm; with load backrest 1500mm height, h₄ + 1008mm

⁽²⁾ All weights are: mast structures (weldment, cylinders, chain, pulley) + carriage + oil. EXCLUDED: forks, accessories.

⁽³⁾ With load backrest 700mm width, 1000mm height, weight + 18kg; with load backrest 700mm width, 1500mm height, weight + 26kg

All values are nominal values and they are subject to tolerances.

For further information, please contact the manufacturer.

Yale products might be subject to change without notice.

Lift trucks illustrated may feature optional equipment.

Values may vary with alternative configurations.



MRE series

Models: MR10E, MR12E, MR14E

Overhead Guard

The one piece welded overhead guard gives a good visibility to all directions. The two different pillar profiles give adequate stiffness strength, with a minimum impact on visibility. As option drive-in overhead guards are available.



Operator compartment

The operator compartment structure is a one piece welded structure developed for long term durability. It is bolted on the frame having boxed bottom part for stiff compartment and reduced vibrations to the operator.

The step with grip profile has a maximum depth of 130mm and low height of 370mm.

Frame

Completely welded base frame is available in 2 basic widths and 2 different lengths.

Seats

Two different full-suspension seats with additional options are available, both of which are adjustable for operator weight, fore/aft position and backrest angle.

Steering console

The steering console is one hand adjustable for length to provide the optimum position for the operator.

To improve operators left arm ergonomics the steering column is slightly 3° angled anti clockwise.

Steering system

The steering system is a fully fly-by-wire system. The steer wheel input and the steer motor output are connected to the controller and managed by the VCM.



The steer positioning sensors provide feedback of the actual steer position. The standard steering has a 180° steer angle, a 360° option is available and enabled by the VCM software. A third option allows switching from 180° to 360° by pressing a steering mode selection switch on the dashboard. Speed reduction on cornering is automatic and can be adjusted.

Foot pedals

The operator presence switch is slightly rotated to the mid line off the operator seat to improve operator left foot position. The thick one piece floor mat absorbs vibrations and noise out of the motor compartment.

Dash display

The display is integrated in the dashboard in front of the operator. In this location the display is easy to read and to operate.

The standard display utilises the proven display design from Yale ECB trucks.

Vehicle Control Manager

The Vehicle Control Manager (VCM) is the central module of the truck and it is linked to the truck modules via Dual CANbus system to increase reliability and truck dependability. With this proven technology used in the automobile sector point to point wiring is greatly reduced.

Hydraulic controls

The Hydraulic controls are integrated in an ergonomic sliding armrest under the driver's right hand. The standard controls is proven AccuTouch™ mini-levers module with separate horn and direction switches. A joystick with integrated mini lever joystick for best ergonomic hydraulic operation is available as option.





Mast

A 3 stage full free lift mast reduces the total mast channel width. The mast tilts forward up to 1° and backward up to 3°, depending on the lift height.

Lift cylinders position optimised to increase operator visibility and cross members are not in direct line of visibility for critical heights.

Motors

The AC drive motor is standard across the model range.

Optimised acceleration and travel speed performance (up to 11km/h) delivers high load handling efficiency productivity. Easy access through swing-open motor compartment door. The steering motor also uses AC technology for precise steering control. On power up the drive wheel is automatically centred. A removable plate allows access to the drive tyre/gear reducer for servicing. The motor compartment including the hoist motor is ventilated.



MRE series

Models: MR10E, MR12E, MR14E



HYSTER-YALE UK LIMITED

trading as **Yale Europe Materials Handling**
Centennial House, Frimley Business Park,
Frimley, Surrey GU16 7SG, United Kingdom.



Tel: +44 (0) 1276 538500
Fax: +44 (0) 1276 538559

www.yale-forklifts.eu



Publication part no. 220990390 Rev.00 Printed in The Netherlands (0718HG) EN.

Safety: This truck conforms to the current EU requirements. Specification is subject to change without notice.

Yale, VERACITOR and  are registered trademarks. "PEOPLE, PRODUCTS, PRODUCTIVITY", PREMIER, Hi-Vis, and CSS are trademarks in the United States and certain other jurisdictions. MATERIALS HANDLING CENTRAL and MATERIAL HANDLING CENTRAL are Service Marks in the United States and certain other jurisdictions.  is a Registered Copyright.

©Yale Europe Materials Handling 2018. All rights reserved. Truck shown with optional equipment.
Country of Registration: England and Wales. Company Registration Number: 02636775