

GP 15-35MX

Internal Combustion
Counterbalanced Forklift

1500-3500 KG



About Yale®

The Yale GP15-35MX counterbalanced forklift has been engineered to provide the perfect combination of power, speed, low fuel consumption and clean performance.

Built for demanding work cycles and available with a range of standard and optional features, the GP15-35MX model line-up is a powerful addition to maintain optimum customer performance.

- Available in LPG, Diesel and Dual Fuel
- Load capacity from 1,500-3,500kg
- Advanced control and operational functions; Traction Interlock, Hydraulic Interlock, side shift and fork positioners
- Wide variety of attachments
- Ergonomic design
- Designed for optimum accessibility in servicing
- Backed by an extensive dealer network
- Aftermarket parts, service and support

All Yale® products are backed by a regional dealer network which shares the manufacturer's commitment to Yale maintenance and parts support that is highly dependable and highly competitive over the whole life of the truck.

Yale dealerships provide flexible truck servicing solutions and are linked to one of the industry's most sophisticated parts distribution operations. You'll find support for Yale Lift Trucks throughout the Asia-Pacific region, provided by a big regional footprint stretching from Australia and New Zealand on through Singapore, Malaysia, Indonesia, Thailand, South Korea, Taiwan, Vietnam, the Philippines, Guam and India.





MX Series Features



ACRYLIC COVER*

Provides a clear view above the operator whilst protecting from rain and falling objects.



REVERSE ASSIST GRIP*

Enables operators to reverse without the need to take their hands off the steering wheel or grip. Also includes a thumb activated horn button for ease of operation.

ERGONOMIC SEAT

Operators can select their desired seating position with the option of a wide slide and reclining range. The weight adjustment knob on the full suspension seat ensures the most suitable suspension for the individual.

EASY OPERATOR ACCESS

The low wide step, ample shoulder clearance and flow lined design of engine hood ensures easy operator accessibility upon unit ingress/egress.



CONTINUOUS STABILITY ENHANCEMENT (CSE)

The maintenance free CSE enhances lateral stability without compromising uneven surface travel, through reducing truck lean by limiting the articulation of the steer axle.



ALL WEATHER STEEL CABIN*

Steel cabin protects the operator and provides comfort under harsh working conditions.

*Optional



OPERATIONAL ALERTS

Audible and visible operational alerts including signal lights, rotating beacons and back-up alarm.

HI-VIS™ MAST

Enhanced operator visibility through the Hi-Vis™ Mast to the fork tips, means the operator can travel forward with greater confidence.



SIDE SHIFT*

Optional feature for adjusting and aligning loaded goods, enabling utmost productivity.



ADJUSTABLE STEERING COLUMN

Offset steering column provides ideal left hand steering while the small diameter steering wheel reduces risk of shoulder injury.

OPERATOR PRESENCE SYSTEM

Traction Interlock automatically reverts the truck to neutral and Hydraulic Interlock disables the load levers when the operator is not seated to prevent incidents caused by an unintentional operation of the pedals or levers.

All your materials handling needs under control

The Yale® MX Series is a perfect illustration of the ongoing Yale commitment to innovative design, exceptional quality and industry leading performance.

The MX takes productivity, operator comfort, serviceability and dependability to a new high, and cost of ownership to a new low.

Whether it's pioneering new features designed to provide more efficient handling than ever before or ingenious improvements to help optimise lift truck reliability, trust the MX to deliver an unprecedented level of control over all your materials handling operations.

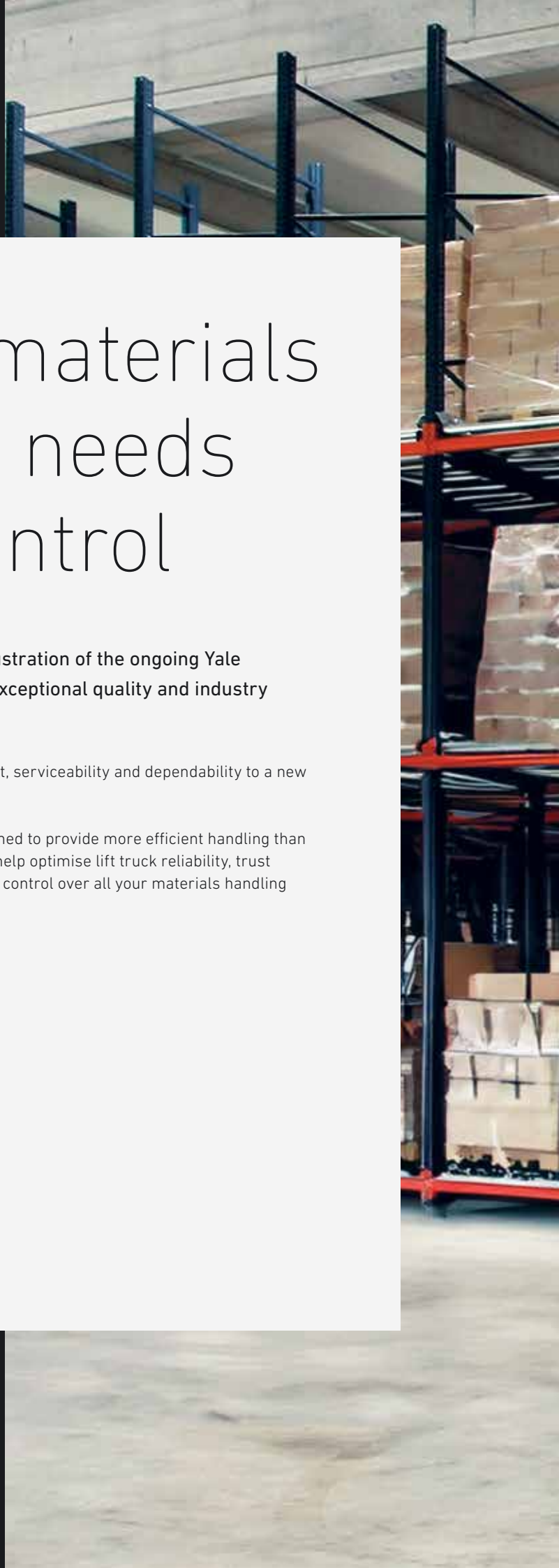



Setting the standard for operational efficiency



INNOVATIVE COOLING SYSTEM

The cooling system operates at lower temperatures. This offers significant improvement when it comes to cooling air flow, increasing component life and minimising the risk of overheating in heavy-duty applications. Optimised ducting and high volume tunnels allow Yale® MX lift trucks to run longer in a cooler state. Radiators are shockproof mounted for long life.

Yale MX transmissions gear profiles optimised to reduce operator noise in conjunction with isolated powertrain, minimising operator fatigue and improving comfort.

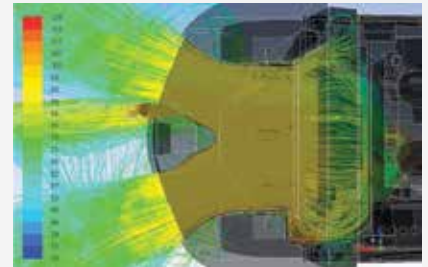

Maximised airflow for enhanced cooling.



Serpentine or square wave radiator – all models.

INTEGRATED DASH DISPLAY

- Hour meter, date, time and alarm
- Travel speed/load weight indicator
- Coolant temperature level and fuel gauge indicator
- Password entry
- Error codes
- Visual warnings; battery charge, engine oil pressure, transmission fluid temperature, service reminder and seat belt.



Dash display

CONTINUOUS STABILITY ENHANCEMENT (CSE)

The maintenance free CSE enhances lateral stability without compromising uneven surface travel, through reducing truck lean by limiting the articulation of the steer axle.



CSE



Comfortably more productive

Yale has always prided itself on the intelligent ergonomics of its fork lift trucks and the MX Series, like many a Yale® truck before it, sets the standards for comfort and control.

Take the hydraulic control module with shorter reach and throw levers requiring less effort to operate. Or the exceptional user visibility for this class of truck afforded by the Yale Hi-Vis™ mast. In fact, wherever you look in the cabin, there's a feature designed to add to the comfort of the operator, from the low step height to the fully adjustable suspension seat, from the interactive dash display to the rear drive handle with horn.

Add other operator friendly features such as the low noise hydraulic pump and cabin together with the seamless forward and reverse directional changes, controlled through two optional methods, being the steer column mounted directional lever or the foot directional control (FDC) and it's easy to see why drivers love the MX – and employers love the way it increases their productivity.



1 SHIFT LEVER
As standard, two levers operate the turn signal and forward/reverse operation. The right hand side turn signal includes a light switch (with auto canceller). Left hand lever enables a smooth change of forward/reverse.



2 ERGONOMIC STEERING WHEEL
With a diameter of 300mm, the small wheel is positioned off-set on the left, reducing fatigue and allowing for light operability with only a small rotation of hand movement required.



3 PARKING LEVER
This small stroke lever makes setting the brake easy. Lever includes a release button.



4 INCHING PEDALS
Two types of inching pedals are available to increase the load speed. Pedals are on a suspended mount to free floor space.

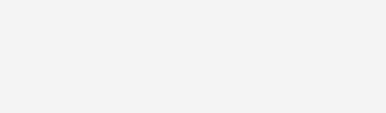

5 HI-VIS™ MAST
Enhanced operator visibility through the Hi-Vis™ Mast to the fork tips, means the operator can travel forward with greater confidence.

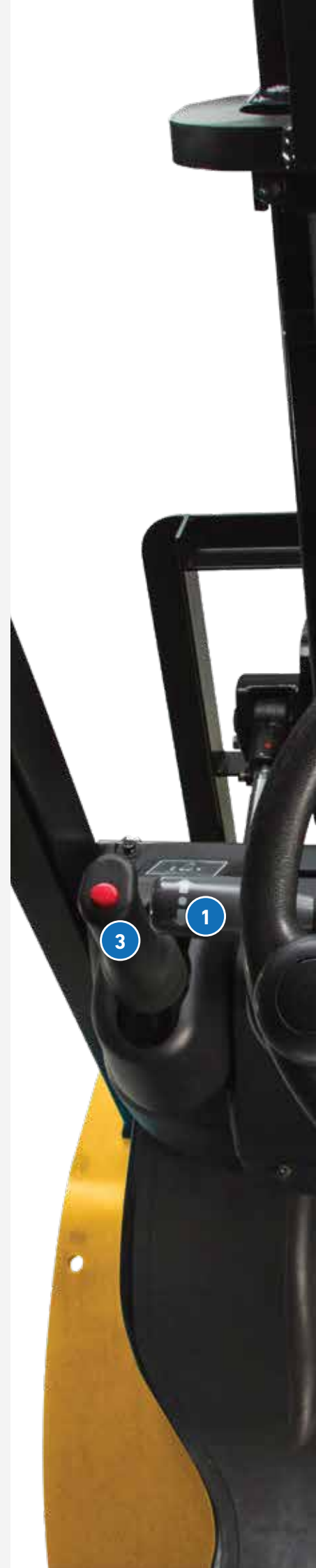



5

2

4

Operators prefer Yale[®] MX lift trucks



With a wide range of ergonomic and technologically advanced features, operators prefer Yale MX lift trucks to keep warehouse operations running efficiently.



1

REVERSE ASSIST GRIP*

Enables operators to reverse without the need to take their hands off the steering wheel or grip. Also includes a thumb activated horn button for ease of operation.



2

TRACTION INTERLOCK MECHANISM - WHEN OPERATOR IS NOT PRESENT

The Traction Interlock function automatically reverts the truck to neutral when an operator is not seated.



3

HYDRAULIC INTERLOCK MECHANISM - WHEN OPERATOR IS NOT SEATED

The Hydraulic Interlock disables the load levers when the operator is not seated to prevent incidents caused by an unintentional operation of the lever.



4

SIDE SHIFT*

Optional feature for adjusting and aligning loaded goods, enabling utmost productivity.

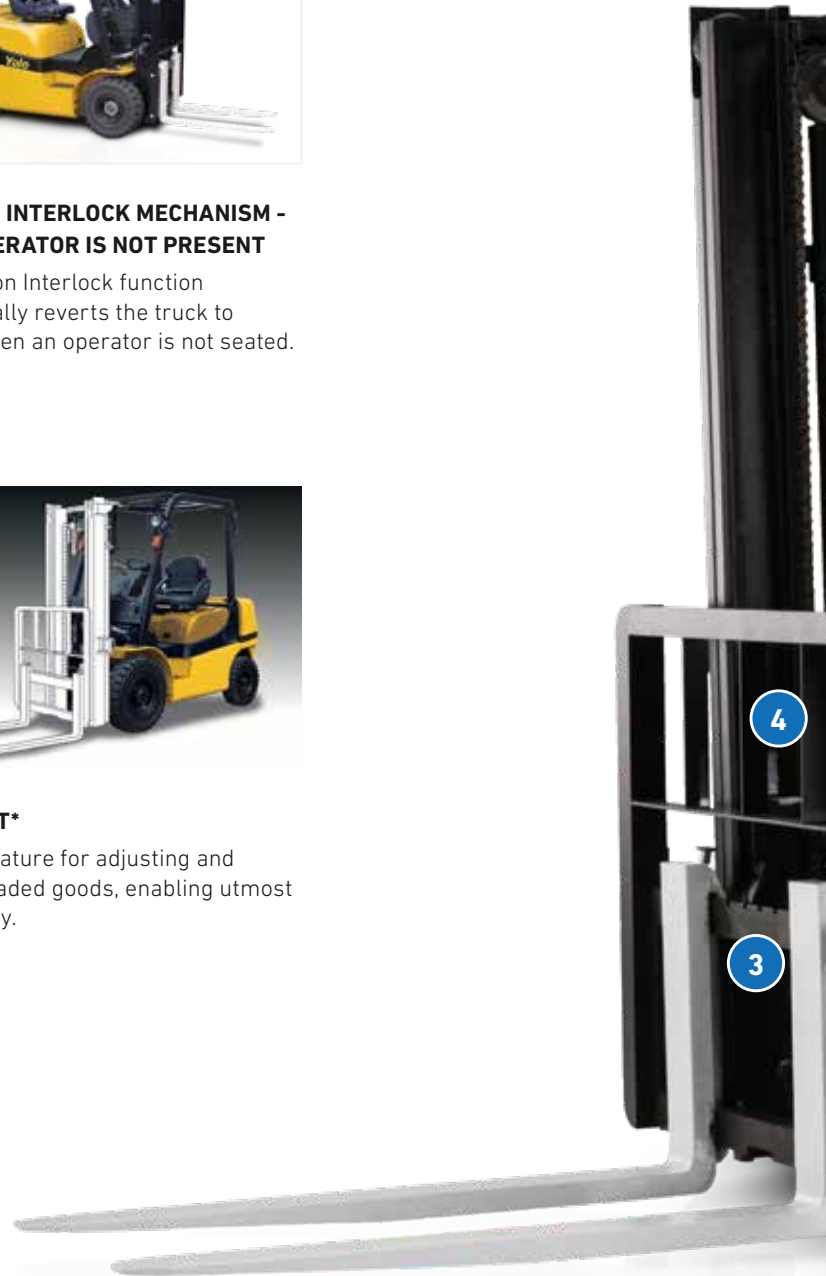

*Optional

5



ISOLATED POWERTRAIN AND FULL SUSPENSION SEAT

Helps to ensure that the operator remains comfortable and productive throughout the shift via the fully adjustable and ergonomic seat, and vibration damping from the isolated powertrain.

6



DRIVING COMFORT

Smaller steering wheel, adjustable steering column and coupled with synchronous steering creates a comfortable and secure working environment.

7



EZ™ - LP GAS TANK BRACKET

The LP tank swings out and drops down for virtually effortless removal and replacement.



Cutting down downtime

The Yale® MX Series doesn't just make it easier to carry out vital servicing tasks. It's a truck that has been designed to actually require less maintenance.

Yale MX lift trucks offer easy service access with a one-piece, rear-opening hood providing cowl-to-counterweight access. An easy to remove floor plate requires no tools and offers complete access to the powertrain.

Equipped with V-ECU the MX's truck functions are continuously monitored and keeps the operator informed of service needs. There's also state of the art on-board diagnostics on the advanced dash display to communicate error codes, enabling quick and accurate repairs.

What's more, when maintenance does need to take place, the MX is designed to make servicing as fast, convenient and simple as possible. It's extremely easy to perform engine compartment daily checks, check and replenish coolant levels and remove the radiator filler cap.

All backed up by the most dependable and most comprehensive parts availability in the industry, the Yale MX gives you a greater degree of control over the efficiency and uptime of your operation than ever before.



1 INTERACTIVE DASH DISPLAY

The interactive dash displays the most relevant information to the truck's current status. By actively showing service reminders and error codes, as well as warning indicators, it enables optimisation of lift truck diagnosis, reducing overall down time.



2 REDUCED SERVICE INTERVALS

500 hour service intervals for planned maintenance.



3 EASY MAINTENANCE

One piece, easy opening hood allows for easy access to the engine compartment.



Total truck reliability

With the MX Series from Yale, total reliability comes built in. Put simply, every last component has been designed to provide long-lasting performance day in, day out, year after year.

Rugged durability is at the heart of the MX. Robust clutch packs, stronger gears and shafts, powertrain protection systems, enhanced monitoring – they all help to boost reliability, maximise uptime and keep your truck performing at its best. There's also a cooling system creating airflow through optimised ducting and high volume tunnels, helping to dramatically increase component life and minimise the risk of overheating in heavy duty applications.

From the shockproof mounted radiators to the check valves incorporated into the cushioned lift cylinders of the world-renowned Yale® mast design, from the sealed connectors that create leak-free joints, enabling the entire truck to be pressure washed, the MX delivers world-class reliability.

By utilising cutting edge technology and superior manufacturing facilities, Yale engineers have delivered the highest serviceability ratings in the industry.

With the reputation for delivering world-class product reliability and to show our confidence in the MX series, it makes sense to back them with industry leading warranty.

That's why Yale is offering the MX series with a standard 3 years/3000 hours* manufacturer warranty and lifetime chassis warranty.



*Comprises of 1 year/2000 hours on complete truck and 3 years/3000 hours on powertrain.





Low cost of ownership built in

The purchase price of materials handling equipment is only one small part of the overall cost of running a fleet of equipment. There is a host of other factors to take into account including periodic maintenance, unscheduled repairs, the cost of replacement tyres, brakes and fuel. Only then can you arrive at a true lifetime cost of ownership.

The Yale® MX Series has been designed to minimise overall operating costs throughout the life of the truck.

The MX helps you take control of fuel costs. In fact, with the MX at the heart of your materials handling operation, you can rest easy knowing you're utilising one of the most fuel efficient trucks in its class. Load sensing hydraulics helps to deliver increased operational efficiency, while each of the seven engines provide superb performance with truly outstanding fuel economy.

Service intervals for planned maintenance extend to 500 hours, reducing service costs and adding to your bottom line.

Last but not least, with its uncluttered layout and ease of access, plus simplified daily checks and reduced service requirements, not to mention its world-class reliability, the MX substantially lowers both labour costs and maintenance costs.





Manage cost, optimise productivity and protect your assets

YALE® VISION WIRELESS ASSET MANAGEMENT

Take your fleet operation to the next level with wireless asset management from Yale. Yale Vision provides true wireless fleet management, can drive fleet efficiency, improves operator performance, reduces your carbon footprint and lowers your overall material handling costs.

- Manage your total cost of operation
- Ensure maximum productivity from your lift truck investment
- Monitor operator behavior, promote safe operator behaviour
- Convenient web-based access, and your choice of three levels of management

DATA IS GREAT, BUT YOUR YALE DEALER WILL MAKE IT WORK FOR YOU

Yale Vision is a great addition to your management toolkit. But when you partner with your Yale Dealer, you get the best of both worlds – great fleet data plus the unmatched knowledge and experience that can help you get the most out of every truck in your fleet.

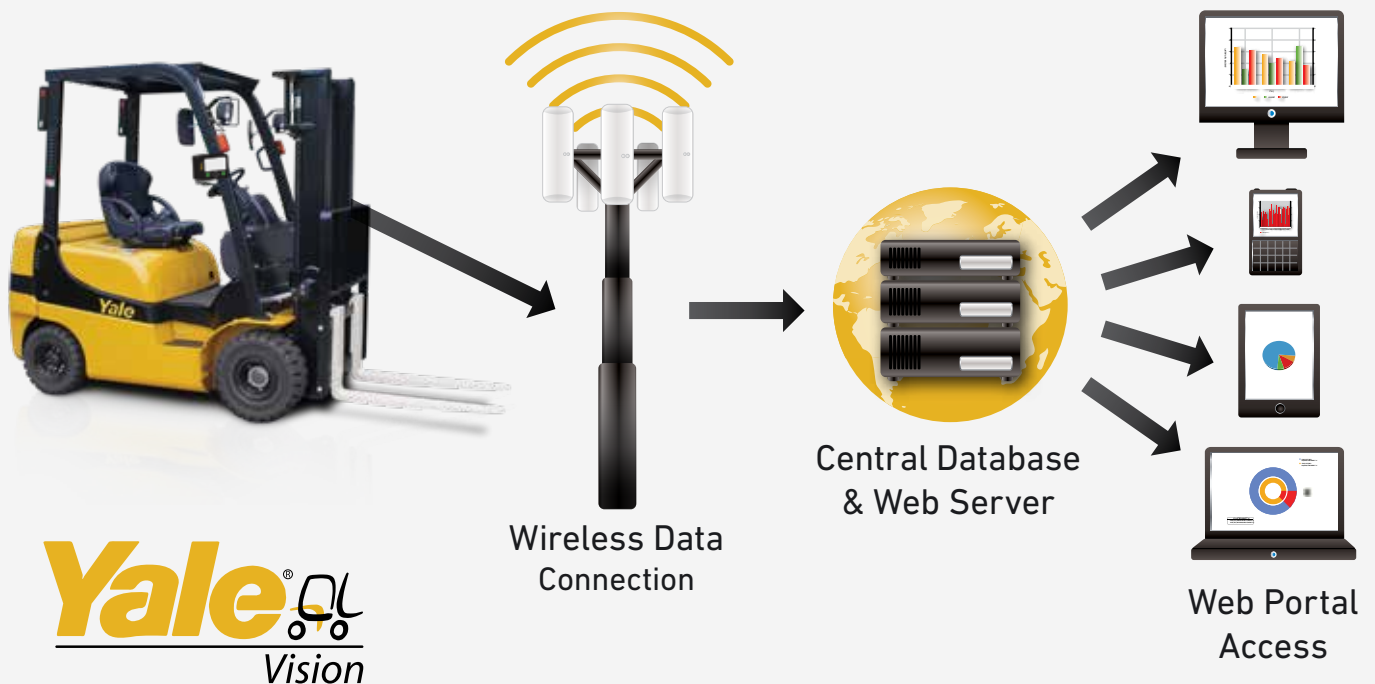

GENERAL SPECIFICATIONS

SPECIFICATION				Dual Fuel/LPG													
				YALE													
1		Manufacturer		GTP/GLP15MX		GTP/GLP18MX		GTP/GLP205MX		GTP/GLP20MX		GTP/GLP25MX		GTP/GLP30MX		GTP/GLP35MX	
2	Model			1500		1750		2000		2500		3000		3500			
3	Capacity	kg		1500		1750		2000		2500		3000		3500			
4	Load centre	mm		500													
7	Tyres			Pneumatic													
8	Wheels	No.front/rear (x=Drive)		2X/2													
9	Lift height	mm	A	3000													
10	Standard free lift	mm	B	145		150		155		160		165					
12	Fork carriage	Carriage width/ITA class	H	920/2		1020/2		1070/3									
13	Fork	Thickness/width/length	mm	35/100/920		40/122/920		40/122/1070		45/122/1070		50/150/1070					
14	Tilt of mast	Forward/backward	deg	6/10													
	Fork spread	Max/min	M/N	915/205		910/250		1010/250		1060/250		1065/305					
	Overall length	Length to tip of forks	mm	F+G	3200	3240	3275	3470	3685	3835	3905						
15	Truck length	Length to face of forks	mm	G	2280	2320	2355	2550	2615	2765	2835						
16	Overall width	Tyre/frame	mm		1070/1070	1135/1070		1160/1140		1235/1140							
16A	Overall width	Tyre/frame (Dual tread)	mm		1190/1070		1590/1140		1490/1140								
17	Height	Height with lowered mast	mm	P	1995				2060		2140						
18		Height with extended mast	mm	K	4105		4120		4125								
19		Height of overhead guard canopy	mm	J	2060		2130		2150								
20	Seat height	mm		920		990		1010									
21	Turning radius	mm	E	1960	1995	2030	2185	2245	2365	2415							
22	Load length 'X'	Centre of front wheel to face of forks	mm	410		415		465		490		505					
23	Right angle stacking aisle width	Add load length and clearance	mm	2165	2205	2240	2470	2530	2650	2715							
24	Travel speed	Laden/unladen with standard engine	km/h	18/19	18/19.5				19/20		15.5/16						
		Laden/unladen with optional engine	km/h	NA				18/19.5		NA							
25	Lifting speed	Laden/unladen with standard engine	mm/s	625/680	615/680		525/580	515/580	515/575	435/485							
		Laden/unladen with optional engine	mm/s	NA				635/695	625/695	NA							
26	Lowering speed	Laden/unladen	mm/s	495/520													
	Drawbar pull	Laden/unladen @ 1.5km/h with standard engine	N	19200	19100	19200	18900		19000	21900							
		Gradeability	N	NA				20400	20500	NA							
	Gradeability	Laden/unladen @ 1.5km/h with standard engine	%	37/24	33/22	30/20	30/26	26/22	24/22	23/19							
		Laden/unladen @ 1.5km/h with optional engine	%	NA				35/26	30/22	NA							
32	Unladen weight	Standard tread	kg	2620	2830	3050	3360	3690	4200	4690							
33	Axle loads	Laden front/rear	kg	3620/500	3990/590	4400/650	4730/630	5470/730	6360/840	7220/970							
34		Unladen front/rear	kg	1150/1470	1110/1720	1100/1950	1550/1810	1480/2210	1620/2580	1670/3020							
36	Tyre sizes	Front (standard tread)		6.00-9-10PR	21x8-9-14PR		7.00-12-12PR		28x9-15-12PR	28x9-15 SOLID							
		Front (dual tread)		21x8-9-14PR				7.00-12-12PR		6.00-15 SOLID							
37		Rear		5.00-8-8PR	18x7-8-10PR		6.00-9-10PR		6.50-10-10PR	6.50-10 SOLID							
38	Wheelbase	mm	L	1410				1625		1700							
39	Tread	Standard tread: front/rear	mm	915/905	950/930		970/1000		1010/1000								
39A		Dual tread: front/rear	mm	1000/905	1000/930		1405/1000		1330/1000								
40	Ground clearance	At lowest point	mm	110				120		140							
41		Centre of wheel base	mm	120				190		210							
42	Service brake	Mechanical/hydraulic/electric/pneumatic		Hydraulic													
43	Parking brake	Foot/hand		Hand													
49	Standard engine	Manufacturer/model		GCT K21				GCT K25									
50		Permanent output	kW	31				34									
51		At revs	rpm	2250				2100									
		Rated torque	Nm/rpm	158/1600				186/1600									
52		No. of cylinder/cubic capacity	cm ³	4/2065				4/2488									
49	Optional engine	Manufacturer/Model		NA				GCT K25		NA							
50		Permanent output	kW	NA				34		NA							
51		At revs	rpm	NA				2100		NA							
		Rated torque	Nm/rpm	NA				186/1600		NA							
52		No. of cylinder/cubic capacity	cm ³	NA				4/2488		NA							
	Fuel tank	Ltr		52				69									
53	Fuel consumption	Ltr/h		ⓘ													
55	Transmission	With ICE drive		AT													
57	Working pressure	For attachments	Mpa	18.1				15.7									
58	Noise level - standard engine	BITA/ISO Leq 3dB Doubling	dB(A)	ⓘ													

GENERAL SPECIFICATIONS

SPECIFICATION				LPG - EFI							
				YALE							
				GLP15MX	GLP18MX	GLP20SMX	GLP20MX	GLP25MX	GLP30MX	GLP35MX	
1	Manufacturer										
2	Model			GLP15MX	GLP18MX	GLP20SMX	GLP20MX	GLP25MX	GLP30MX	GLP35MX	
3	Capacity	kg		1500	1750	2000		2500	3000	3500	
4	Load centre	mm		500							
7	Tyres			Pneumatic							
8	Wheels	No.front/rear (x=Drive)		2X/2							
9	Lift height	mm	A	3000							
10	Standard free lift	mm	B	145		150	155		160	165	
12	Fork carriage	Carriage width/ITA class	H	920/2		1020/2		1070/3			
13	Fork	Thickness/width/length	mm	35/100/920		40/122/920		45/122/1070		50/150/1070	
14	Tilt of mast	Forward/backward	deg	C/D 6/10							
	Fork spread	Max/min	M/N	915/205		910/250	1010/250		1060/250	1065/305	
	Overall length	Length to tip of forks	mm	F+G	3200	3240	3275	3470	3685	3835	3905
15	Truck length	Length to face of forks	mm	G	2280	2320	2355	2550	2615	2765	2835
16	Overall width	Tyre/frame	mm		1070/1070	1135/1070		1160/1140		1235/1140	
16A	Overall width	Tyre/frame (Dual tread)	mm		1190/1070			1590/1140			1490/1140
17	Height	Height with lowered mast	mm	P	1995				2060	2140	
18		Height with extended mast	mm	K	4105		4120		4125		
19		Height of overhead guard canopy	mm	J	2060		2130		2150		
20	Seat height	mm		920			990		1010		
21	Turning radius	mm	E	1960	1995	2030	2185	2245	2365	2415	
22	Load length 'X'	Centre of front wheel to face of forks	mm	410		415	465		490	505	
23	Right angle stacking aisle width	Add load length and clearance	mm	2165	2205	2240	2470	2530	2650	2715	
24	Travel speed	Laden/unladen with standard engine	km/h	18/19.5				19/20		19.5/20	
		Laden/unladen with optional engine	km/h	18/19.5				19/20		19.5/20	
	Lifting speed	Laden/unladen with standard engine	mm/s	675/700		670/700	685/710	680/710	565/585	475/490	
		Laden/unladen with optional engine	mm/s	NA							
	26	Lowering speed	Laden/unladen	mm/s	515/540						
	Drawbar pull	Laden/unladen @ 1.5km/h with standard engine	N	21900	21700	21800	25100	25200	23400	21500	
Gradeability		N	NA								
Gradeability	Laden/unladen @ 1.5km/h with standard engine	%	47/24	42/22	38/19	40/26	34/22	27/21	22/19		
	Laden/unladen @ 1.5km/h with optional engine	%	NA								
32	Unladen weight	Standard tread	kg	2620	2830	3050	3360	3690	4200	4690	
33	Axle loads	Laden front/rear	kg	3620/500	3990/590	4400/650	4730/630	5470/730	6360/840	7220/970	
		Unladen front/rear	kg	1150/1470	1110/1720	1100/1950	1550/1810	1480/2210	1620/2580	1670/3020	
36	Tyre sizes	Front (standard tread)		6.00-9-10PR	21x8-9-14PR		7.00-12-12PR		28x9-15-12PR	28x9-15 SOLID	
		Front (dual tread)		21x8-9-14PR			7.00-12-12PR		6.00-15 SOLID		
		Rear		5.00-8-8PR	18x7-8-10PR		6.00-9-10PR		6.50-10-10PR	6.50-10 SOLID	
38	Wheelbase	mm	L	1410			1625		1700		
39	Tread	Standard tread: front/rear	mm	915/905	950/930		970/1000		1010/1000		
		Dual tread: front/rear	mm	1000/905	1000/930		1405/1000		1330/1000		
40	Ground clearance	At lowest point	mm	Q	110			120		140	
		Centre of wheel base	mm	120			190		210		
42	Service brake	Mechanical/hydraulic/electric/pneumatic		Hydraulic							
43	Parking brake	Foot/hand		Hand							
49	Standard engine	Manufacturer/model		GCT K21			GCT K25				
		Permanent output	kW	38.5			44.7				
		At revs	rpm	2700							
		Rated torque	Nm/rpm	145/2000			169/1600				
		No. of cylinder/cubic capacity	cm ³	4/2065			4/2488				
		Manufacturer/Model		NA							
	Optional engine	Permanent output	kW	NA							
		At revs	rpm	NA							
		Rated torque	Nm/rpm	NA							
		No. of cylinder/cubic capacity	cm ³	NA							
	Fuel tank	Ltr	52			69					
53	Fuel consumption	Ltr/h	☞								
55	Transmission	With ICE drive		AT							
57	Working pressure	For attachments	Mpa	18.1						15.7	
		BITA/ISO Leq 3dB Doubling	dB(A)	☞							

GENERAL SPECIFICATIONS

SPECIFICATION				Diesel									
				YALE									
				GDP15MX	GDP18MX	GDP20SMX	GDP20MX	GDP25MX	GDP30MX	GDP35MX			
1	Manufacturer												
2	Model			GDP15MX	GDP18MX	GDP20SMX	GDP20MX	GDP25MX	GDP30MX	GDP35MX			
3	Capacity	kg		1500	1750	2000		2500	3000	3500			
4	Load centre	mm		500									
7	Tyres			Pneumatic									
8	Wheels	No.front/rear (x=Drive)		2X/2									
DIMENSIONS		9	Lift height	mm	A	3000							
		10	Standard free lift	mm	B	145		150	155		160	165	
		12	Fork carriage	Carriage width/ITA class	H	920/2			1020/2		1070/3		
		13	Fork	Thickness/width/length	mm	35/100/920		40/122/920		40/122/1070	45/122/1070	50/150/1070	
		14	Tilt of mast	Forward/backward	deg	C/D	6/10						
			Fork spread	Max/min	mm	M/N	915/205		910/250	1010/250		1060/250	1065/305
			Overall length	Length to tip of forks	mm	F+G	3200	3240	3275	3470	3685	3835	3905
		15	Truck length	Length to face of forks	mm	G	2280	2320	2355	2550	2615	2765	2835
		16	Overall width	Tyre/frame	mm		1070/1070	1135/1070		1160/1140		1235/1140	
		16A	Overall width	Tyre/frame (Dual tread)	mm		1190/1070			1590/1140			1490/1140
		17		Height with lowered mast	mm	P	1995					2060	2140
		18	Height	Height with extended mast	mm	K	4105		4120		4125		
		19		Height of overhead guard canopy	mm	J	2060		2130		2150		
20	Seat height		mm		920		990		1010				
21	Turning radius		mm	E	1960	1995	2030	2185	2245	2365	2415		
22	Load length 'X'	Centre of front wheel to face of forks	mm		410		415	465		490	505		
23	Right angle stacking aisle width	Add load length and clearance	mm		2165	2205	2240	2470	2530	2650	2715		
PERFORMANCE		24	Travel speed	Laden/unladen with standard engine	km/h	17/18.0	17/18.5		17.5/19		17.5/18.5	17.5/18	
		Laden/unladen with optional engine		km/h	17/18.0	17/18.5		17.5/19		17.5/18.5	17.5/18		
		25	Lifting speed	Laden/unladen with standard engine	mm/s	675/710	665/710	655/710	620/670	610/670	560/570	475/490	
		Laden/unladen with optional engine		mm/s	NA			675/690		NA			
		26	Lowering speed	Laden/unladen	mm/s	495/520							
			Drawbar pull	Laden/unladen @ 1.5km/h with standard engine	N	17500	17400	17500	16700		22300	20400	
	Gradeability	N		NA			21800	21900	NA				
	Gradeability	Laden/unladen @ 1.5km/h with standard engine	%	36/24	32/22	29/20	26/26	22/23	27/22	21/19			
		Laden/unladen @ 1.5km/h with optional engine	%	NA			35/26	30/23	NA				
WEIGHT		32	Unladen weight	Standard tread	kg	2700	2910	3130	3440	3770	4280	4770	
		33	Axle loads	Laden front/rear	kg	3630/550	4020/640	4430/700	4760/680	5500/780	6390/890	7250/1020	
		34		Unladen front/rear	kg	1120/1420	1140/1770	1130/2000	1580/1860	1510/2260	1650/2630	1700/3070	
CHASSIS AND WHEELS		36	Tyre sizes	Front (standard tread)		6.00-9-10PR	21x8-9-14PR		7.00-12-12PR		28x9-15-12PR	28x9-15 SOLID	
		37		Front (dual tread)		21x8-9-14PR			7.00-12-12PR		6.00-15 SOLID		
		37		Rear		5.00-8-8PR	18x7-8-10PR		6.00-9-10PR		6.50-10-10PR	6.50-10 SOLID	
		38	Wheelbase		mm	L	1410			1625		1700	
		39	Tread	Standard tread: front/rear	mm		915/905	950/930		970/1000		1010/1000	
		39A		Dual tread: front/rear	mm		1000/905	1000/930		1405/1000		1330/1000	
		40	Ground clearance	At lowest point	mm	Q	110			120		140	
41	Centre of wheel base	mm			120			190		210			
42	Service brake	Mechanical/hydraulic/electric/pneumatic			Hydraulic								
43	Parking brake	Foot/hand			Hand								
DRIVE		49	Standard engine	Manufacturer/model		YANMAR 4TNE92				YANMAR 4TNE98			
		50		Permanent output	kW	29				43			
		51		At revs	rpm	2050				2300			
				Rated torque	Nm/rpm	150/1400				198/1600			
		52		No. of cylinder/cubic capacity	cm ³	4/2659				4/3319			
		49	Optional engine	Manufacturer/Model		NA	YANMAR 4TNE98				NA		
		50		Permanent output	kW	NA	43				NA		
		51		At revs	rpm	NA	2300				NA		
				Rated torque	Nm/rpm	NA	198/1600				NA		
		52		No. of cylinder/cubic capacity	cm ³	NA	4/3319				NA		
	Fuel tank	Ltr		52					69				
53	Fuel consumption	Ltr/h											
55	Transmission	With ICE drive		AT									
OTHERS		57	Working pressure	For attachments	Mpa	18.1				15.7			
		58	Noise level - standard engine	BITA/ISO Leq 3dB Doubling	dB(A)								

GENERAL SPECIFICATIONS

		Diesel – Tier 4							
SPECIFICATION	1	Manufacturer	YALE						
	2	Model	GP20MX	GP25MX	GP30MX	GP35MX			
	3	Capacity	kg	2000	2500	3000	3500		
	4	Load centre	mm	500					
	7	Tyres		Pneumatic					
	8	Wheels	No.front/rear (x=Drive)	2X/2					
	9	Lift height	mm	A	3000				
	10	Standard free lift	mm	B	155	160	165		
DIMENSIONS	12	Fork carriage	Carriage width/ITA class	H	1020/2	1070/3			
	13	Fork	Thickness/width/length	mm	40/122/920	45/122/1070	50/150/1070		
	14	Tilt of mast	Forward/backward	deg	C/D	6/10			
		Fork spread	Max/min	mm	M/N	1010/250	1060/250	1065/305	
		Overall length	Length to tip of forks	mm	F+G	3470	3685	3835	3905
	15	Truck length	Length to face of forks	mm	G	2550	2615	2765	2835
	16	Overall width	Tyre/frame	mm		1160/1140		1235/1140	
	16A	Overall width	Tyre/frame (Dual tread)	mm		1590/1140			1490/1140
	17	Height	Height with lowered mast	mm	P	1995	2060	2140	
	18		Height with extended mast	mm	K	4120			
	19		Height of overhead guard canopy	mm	J	2130	2150		
	20	Seat height		mm		990	1010		
	21	Turning radius		mm	E	2185	2245	2365	2415
	22	Load length 'X'	Centre of front wheel to face of forks	mm		465	490	505	
	23	Right angle stacking aisle width	Add load length and clearance	mm		2470	2530	2650	2715
PERFORMANCE	24	Travel speed	Laden/unladen with standard engine	km/h	18/19.5		17.5/18.5		
	Laden/unladen with optional engine		km/h	NA					
	25	Lifting speed	Laden/unladen with standard engine	mm/s	675/700		560/575	490/505	
	Laden/unladen with optional engine		mm/s	NA					
	26	Lowering speed	Laden/unladen	mm/s	495/520				
		Drawbar pull	Laden/unladen @ 1.5km/h with standard engine	N	21600	21700	22200	20300	
Gradeability			N	NA					
	Gradeability	Laden/unladen @ 1.5km/h with standard engine	%	35/25	30/22	26/21	21/19		
		Laden/unladen @ 1.5km/h with optional engine	%	NA					
WEIGHT	32	Unladen weight	Standard tread	kg	3650	3790	4290	4690	
	33	Axle loads	Laden front/rear	kg	5080/580	5550/740	6470/840	7410/910	
	34		Unladen front/rear	kg	1870/1780	1570/2220	1720/2580	1760/2960	
CHASSIS AND WHEELS	36	Tyre sizes	Front (standard tread)		7.00-12-12PR		28x9-15-12PR	28x9-15 SOLID	
			Front (dual tread)		7.00-12-12PR			6.00-15 SOLID	
			Rear		6.00-9-10PR	6.50-10-10PR	6.50-10 SOLID		
	38	Wheelbase		mm	L	1625	1700		
	39	Tread	Standard tread: front/rear	mm		970/1000	1010/1000		
	39A		Dual tread: front/rear	mm		1405/1000		1330/1000	
	40	Ground clearance	At lowest point	mm	Q	120	140		
	41		Centre of wheel base	mm		190	210		
	42	Service brake	Mechanical/hydraulic/electric/pneumatic			Hydraulic			
43	Parking brake	Foot/hand			Hand				
DRIVE	49	Standard engine	Manufacturer/model			KUBOTA V2403			
			Permanent output	kW		43			
			At revs	rpm		2400			
			Rated torque	Nm/rpm		199/1500			
	52		No. of cylinder/cubic capacity	cm ³		4/2434			
	50	Optional engine	Manufacturer/Model			NA			
			Permanent output	kW		NA			
			At revs	rpm		NA			
			Rated torque	Nm/rpm		NA			
	52		No. of cylinder/cubic capacity	cm ³		NA			
			Fuel tank	Ltr		69			
	53		Fuel consumption	Ltr/h		☎			
55	Transmission	With ICE drive			AT				
OTHERS	57	Working pressure	For attachments	Mpa		18.1	15.7		
	58	Noise level - standard engine	BITA/ISO Leq 3dB Doubling	dB(A)		☎			

Mast Specifications

GP15MX				
Maximum Fork Height mm	Back Tilt deg	Overall Lowered Height mm	Overall Extended Height mm	Free Lift mm
SIMPLEX MAST				
3035	10	1995	4105	145
3335	10	2145	4405	145
3535	10	2245	4605	145
3735	10	2345	4805	145
4035	6	2595	5105	145
4335	6	2745	5405	145
4535	6	2845	5605	145
4835	6	2995	5905	145
5035	6	3095	6105	145
DUPLEX MAST				
3025	10	1995	4095	925
3325	10	2145	4395	1075
3525	10	2245	4595	1175
3725	10	2345	4795	1275
4125	6	2595	5195	1525
TRIPLEX MAST				
4025	6	1895	5095	825
4375	6	1995	5445	925
4525	6	2045	5595	975
4825	6	2145	5895	1075
5125	6	2245	6195	1175
5425	6	2345	6495	1275
6025	6	2595	7095	1525

GP18MX				
Maximum Fork Height mm	Back Tilt deg	Overall Lowered Height mm	Overall Extended Height mm	Free Lift mm
SIMPLEX MAST				
3035	10	1995	4105	145
3335	10	2145	4405	145
3535	10	2245	4605	145
3735	10	2345	4805	145
4035	6	2595	5105	145
4335	6	2745	5405	145
4535	6	2845	5605	145
4835	6	2995	5905	145
5035	6	3095	6105	145
DUPLEX MAST				
3025	10	1995	4095	925
3325	10	2145	4395	1075
3525	10	2245	4595	1175
3725	10	2345	4795	1275
4125	6	2595	5195	1525
TRIPLEX MAST				
4025	6	1895	5095	825
4375	6	1995	5445	925
4525	6	2045	5595	975
4825	6	2145	5895	1075
5125	6	2245	6195	1175
5425	6	2345	6495	1275
6025	6	2595	7095	1525

GP20SMX				
Maximum Fork Height mm	Back Tilt deg	Overall Lowered Height mm	Overall Extended Height mm	Free Lift mm
SIMPLEX MAST				
3040	10	1995	4105	150
3340	10	2145	4405	150
3540	10	2245	4605	150
3740	10	2345	4805	150
4040	6	2595	5105	150
4340	6	2745	5405	150
4540	6	2845	5605	150
4840	6	2995	5905	150
5040	6	3095	6105	150
DUPLEX MAST				
3030	10	1995	4095	930
3330	10	2145	4395	1080
3530	10	2245	4595	1180
3730	10	2345	4795	1280
4130	6	2595	5195	1530
TRIPLEX MAST				
4030	6	1895	5095	830
4380	6	1995	5445	930
4530	6	2045	5595	980
4830	6	2145	5895	1080
5130	6	2245	6195	1180
5430	6	2345	6495	1280
6030	6	2595	7095	1530

GP20-25MX				
Maximum Fork Height mm	Back Tilt deg	Overall Lowered Height mm	Overall Extended Height mm	Free Lift mm
SIMPLEX MAST				
3050	10	1995	4120	155
3350	10	2170	4420	155
3550	10	2270	4620	155
3750	10	2420	4820	155
4050	10	2620	5120	155
4350	6	2770	5420	155
4550	6	2870	5620	155
4850	6	3020	5920	155
5050	6	3120	6120	155
DUPLEX MAST				
3000	10	1995	4070	925
3390	10	2270	4460	1200
3590	10	2370	4660	1300
3840	10	2520	4910	1450
4190	6	2720	5260	1650
TRIPLEX MAST				
4135	6	1970	5210	900
4345	6	2040	5420	970
4585	6	2120	5660	1050
4840	6	2205	5910	1135
5035	6	2270	6110	1200
5335	6	2370	6410	1300
5535	6	2470	6610	1400
5685	6	2520	6760	1450
6035	6	2720	7110	1650

Mast Specifications

GP30MX				
Maximum Fork Height mm	Back Tilt deg	Overall Lowered Height mm	Overall Extended Height mm	Free Lift mm
SIMPLEX MAST				
3055	10	2060	4125	160
3355	10	2210	4425	160
3555	10	2310	4625	160
3755	10	2440	4825	160
4055	10	2640	5125	160
4355	6	2790	5425	160
4555	6	2890	5625	160
4855	6	3040	5925	160
5055	6	3140	6125	160
DUPLEX MAST				
3080	10	2140	4150	1070
3380	10	2290	4450	1220
3580	10	2390	4650	1320
3830	10	2540	4900	1470
4180	6	2740	5250	1670
TRIPLEX MAST				
4125	6	1990	5195	920
4335	6	2060	5405	990
4575	6	2140	5645	1070
4705	6	2225	5775	1155
5025	6	2390	6095	1320
5325	6	2540	6395	1470
5525	6	2640	6595	1570
5725	6	2740	6795	1670
6025	6	2890	7095	1820

GP35MX				
Maximum Fork Height mm	Back Tilt deg	Overall Lowered Height mm	Overall Extended Height mm	Free Lift mm
SIMPLEX MAST				
3060	10	2140	4080	165
3360	10	2290	4380	165
3560	10	2390	4580	165
3760	10	2490	4780	165
4060	10	2690	5080	165
4360	6	2840	5380	165
4560	6	2940	5580	165
4860	6	3090	5880	165
5060	6	3190	6080	165
DUPLEX MAST				
3085	10	2190	4105	1120
3385	10	2340	4405	1270
3585	10	2440	4605	1370
3835	10	2590	4855	1520
4185	6	2790	5205	1720
TRIPLEX MAST				
4130	6	2040	5150	970
4340	6	2110	5360	1040
4580	6	2190	5600	1120
4830	6	2340	5850	1270
5030	6	2440	6050	1370
5330	6	2590	6350	1520
5530	6	2690	6550	1620
5730	6	2790	6750	1720
6030	6	2940	7050	1870

Note: Overall Extended Height and Free Lift based on standard load backrest height of 1070mm.

Capacity Charts

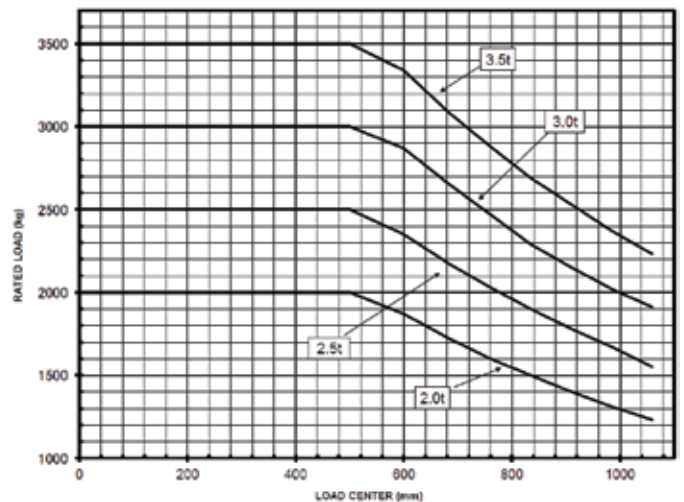
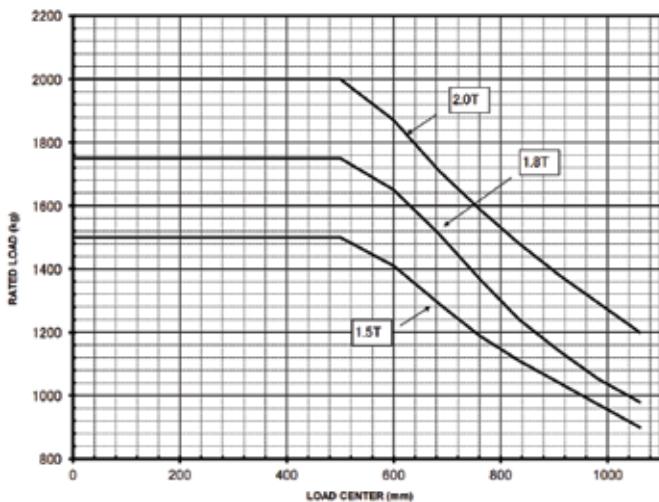

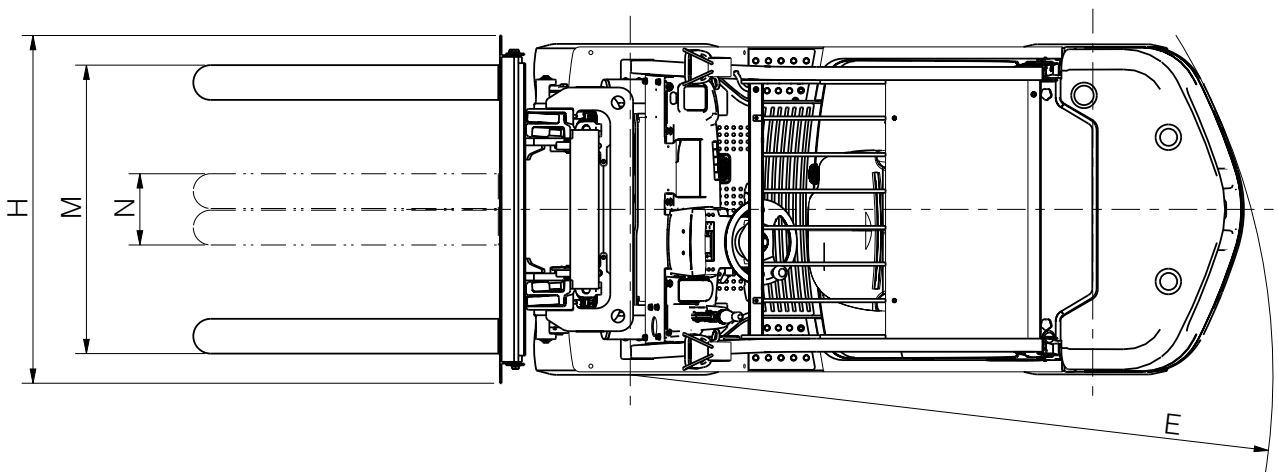
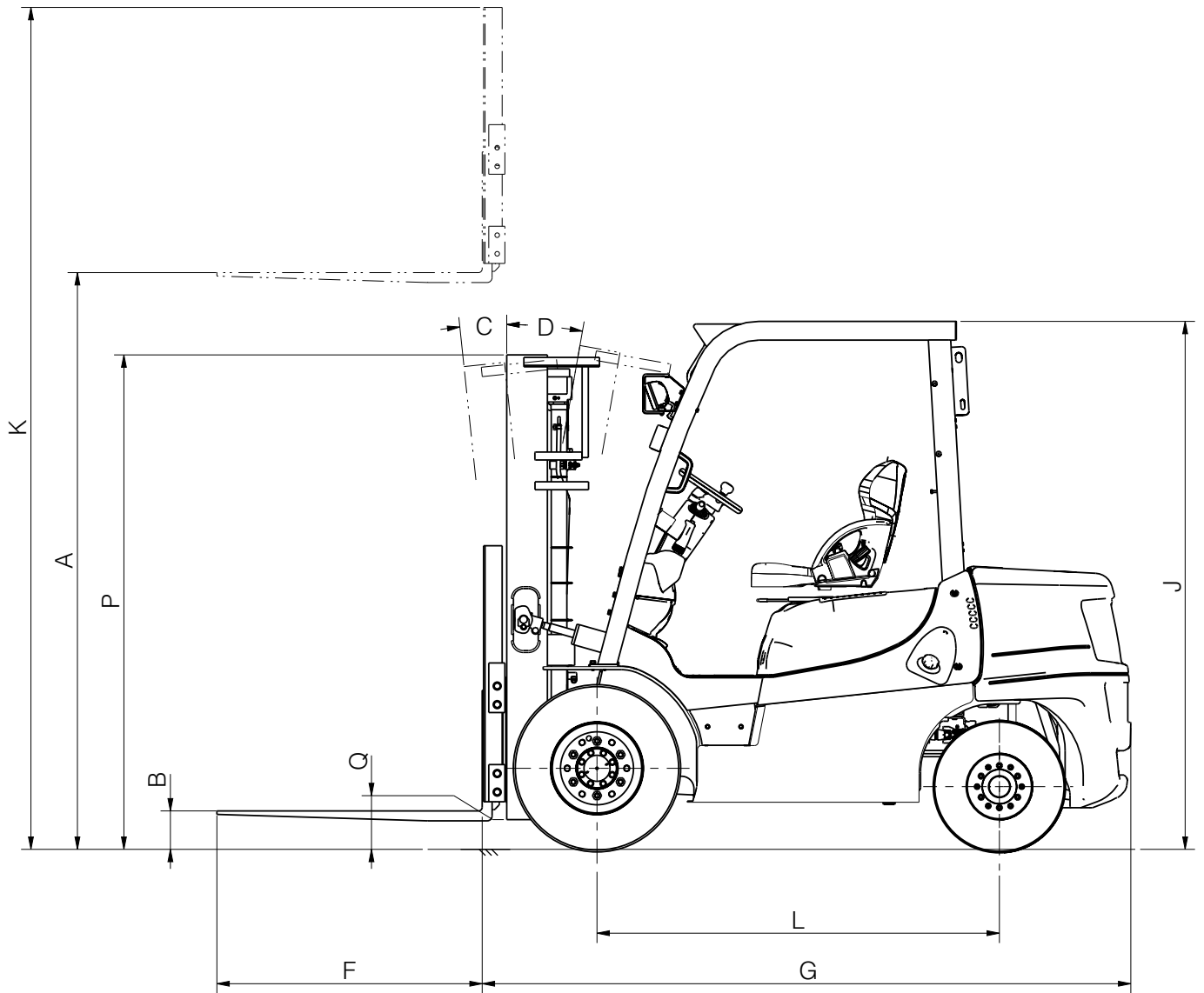

Standard & optional features

STANDARD

- Simplex mast

- Operator presence
 - Hydraulic Interlock
 - Traction Interlock

- Cowl mounted levers

- Trunnion mount mast

- Full halogen light kit including turn indicators

- Head light guards

- Rotating LED beacon

- Swing down LPG bracket

- Small diameter steering wheel

- Rubber floor mat

- Entry assist grip

- Electric directional shift lever

- Neutral start

- Reverse alarm

- Separate inch/brake pedal

- Comprehensive dash display

- Single element air cleaner

- Rubber mount rear axle

- Wide mast with wide field vision

OPTIONS

- Engine options – LPG, Diesel, Dual Fuel

- Mast options
 - simplex mast – 3,000mm to 5,000mm lift
 - duplex mast – 3,300mm to 4,100mm lift
 - triplex mast – 4,000mm to 6,000mm lift

- Integral side shift carriage

- Fork lengths – 920mm to 2,120mm

- Tyre options – pneumatic, solid, non-marking

- Control valve options

- Front screens

- Rain covers

- Cabs

- Pre-cleaner for air filter

- LED lighting

- Speed meter

- Load weight meter

- Special paint

- Reverse assist grip with horn button

- Yale® Vision Telemetry

About Yale



Yale Lift Truck Technologies leverages over a century of material handling experience and substantial investment in innovation to bring the most advanced technology-driven lift truck solutions to market. The company offers a full line of award-winning lift trucks, including reach trucks, order pickers, turret trucks, pallet jacks and trucks, pallet stackers, tow tractors and counterbalanced forklifts, as well as powerful operator assist solutions, proven robotics and a wide range of power sources to help customers adapt to today's demanding supply chain. Yale and its independent dealer network support these solutions with comprehensive after-sales service, parts, financing and training.

Yale Lift Truck Technologies is a trading name of Hyster-Yale Asia-Pacific Pty Ltd., a wholly owned subsidiary of Hyster-Yale Materials Handling, Inc. (NYSE:HY) which is headquartered in Cleveland, Ohio and operates globally.

MATERIALS HANDLING FOR:

3PL

Auto Parts Distribution

Beverage

Cold & Frozen Foods

Food Distribution

Food Processing

Furniture & Furnishings

Government

Health & Pharma

Home Centers

Retail & E-commerce

Yale Pacific

1/23 Rowood Road, Prospect NSW 2148

Tel: +61 (2) 9795 3800 | Fax: +61 (2) 9792 8484

Yale Asia

16 Tuas Avenue 20, Singapore 638827

Tel: +65 6863 3387 | Fax: +65 6863 3349

yale.com

© 2023 Hyster-Yale Group, Inc., all rights reserved. YALE and  are trademarks of Hyster-Yale Group, Inc. Trucks may be shown with optional equipment and/or features not available in all regions. Specifications and details in this brochure are subject to change without prior notification.