

ERC series

2500 / 3000kg

4 Wheel Electric Forklift



SPEC SHEET

Models: ERC050VGL, ERC060VGL

TRUCK DIMENSIONS ERC050-060VGL

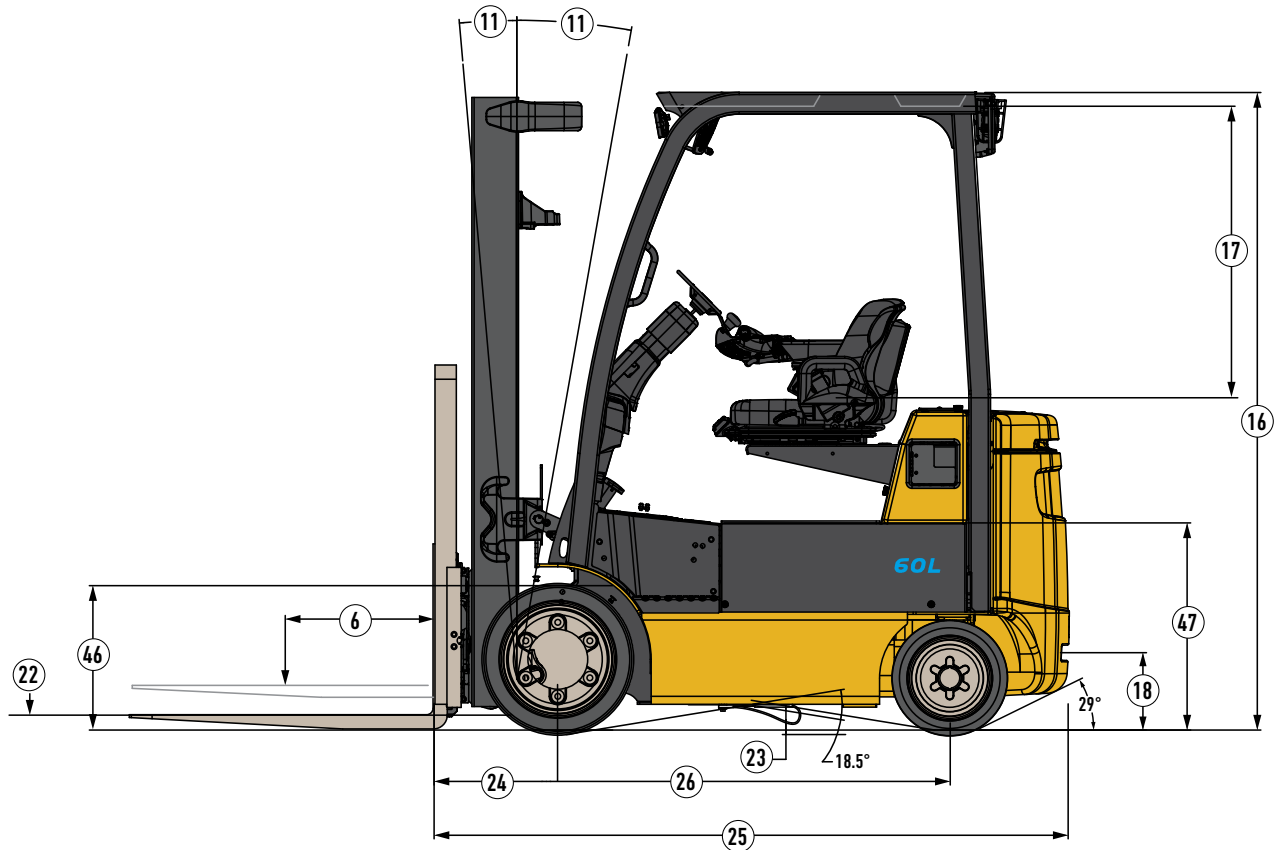
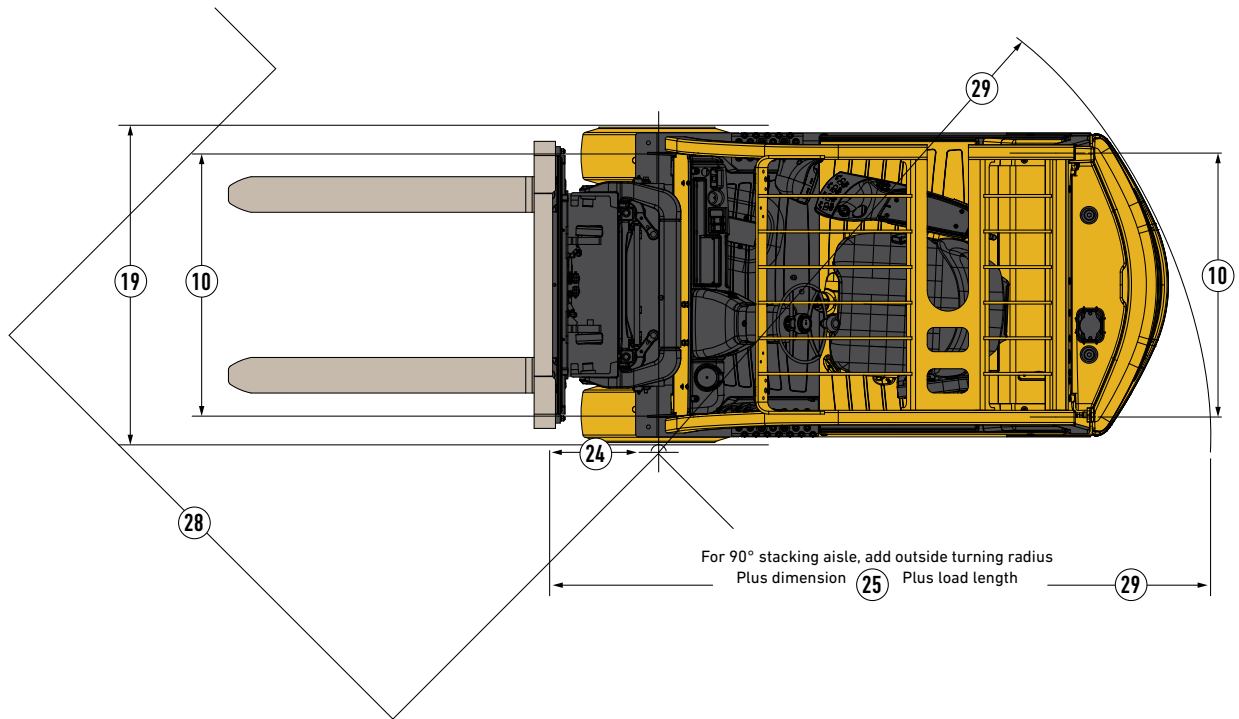

Circled truck dimensions correspond to the line numbers in the General Specifications chart. Dimensions are listed in inches (millimeters).

GENERAL SPECIFICATIONS ERC050-060VGL

GENERAL				Yale	
1	Manufacturer			ERC050VGL	ERC060VGL
2	Model designation			Electric	
3	Power type			Sit	
4	Operator type				
5	Rated capacity		lb (kg)	5000 (2268)	6000 (2722)
6	Load center		in (mm)	24 (610)	
TIRES				Cushion/ Cushion	
7	Tire type - cushion, solid, pneumatic etc.	Drive/steer		Cushion/ Cushion	
8	Tire size	Drive/steer	in	21x7x15 / 16x5x10.5	21x7x15 / 16x5x10.5
9	Wheels - numbers	X=Driven	in (mm)	2X / 2	
10	Tread	Tires	in (mm)	35.1/41.9/37 (892/1064/940)	35.6/40.9/36 (905/1039/915)
11	Mast tilt	Std Opt Opt	degrees	5F5B 10F/5B (5F/4B)	
12	Mast - lowered height	Std mast	in (mm)	83 (2085)	
13	Free lift - top of fork	Std 2 stg limited free lift mast	in (mm)	5(140)	
14	Opt 2 stg full free mast with/without LBR		in (mm)	33/60 (860/1525)	33/56 (855/1440)
15	Lift height-top of fork	Std 2 stg limited free lift mast	in (mm)	125 (3192)	118 (3009)
16	Mast - extended height/wheel to fork tips	Std mast with/without LBR	in (mm)	174/148 (4415/3740)	167/144 (4235/3655)
17	Overhead guard height	Std/drive in rack/opt/opt flat plate	in (mm)	91.5/91.5/89.5/87.4 (2324/2324/2273/2213)	
18	SIP to bottom std OHG	R5usp at mid-point Std/susp/swivel	in (mm)	35.3/34.4/34.3 (899/874/872)	
19	Tow pin height	Vertical center of pin	in (mm)	11 (280)	
20	Overall width	Standard tread/wide tread	in (mm)	42.1/48.9 (1070/1242)	43.6/48.9 (1108/1242)
21	Forks	Thickness x width x length	in (mm)	1.6 x 3.9 x 42 (40 x 100 x 1067)	2 x 4.9 x 42 (50 x 125 x 1067)
22	Standard carriage width	Class II	in (mm)	38.5 (977)	
23	Ground clearance	Lowest point	in (mm)	3.6/3.3 (91/85)	
24	Ground clearance	Center of truck	in (mm)	3.9/3.6 (98/92)	3.7/3.6 (94/92)
25	Load distance	Center of wheel to face of forks	in (mm)	15.4 (390)	15.8 (402)
26	Length to face of forks	Chassis length	in (mm)	84.3 (2143)	86.5 (2199)
27	Wheelbase		in (mm)	54.2 (1377)	
28	Right angle stack		in (mm)	137.5 (3493)	139.2 (3536)
29	Equal aisle	90° Intersecting aisle	in (mm)	73.1 (1858)	74.2 (1885)
30	Outside turning radius		in (mm)	74.2 (1884)	75.4 (1915)
WT.					
31	Truck weight	NL	lb (kg)	9180 (4170)	10240 (4650)
32	Axle loading - drive	Static w/max. wt. battery	lb (kg)	4090 (1860) / 12730 (1460)	4180 (1900) / 14590 (6620)
33	Axle loading - steer	Static w/max. wt. battery	lb (kg)	5100 (2315) / 5780 (665)	6070 (2755) / 6620 (755)
34	Travel speed	Extended shift OFF	mph (km/h)	12.3/12.5 (19.8/20.1)	
35	Lift speed	Extended shift ON	mph (km/h)	12.2/12.2 (19.7/19.7)	12.2/12.1 (19.7/19.4)
36	Lower speed	Std 2 stg FFL mast	ft/min (m/sec)	142/96 (0.72/0.49)	124/83 (0.63/0.42)
37	Gradeability	Opt 2 stg FFL mast	ft/min (m/sec)	130/93 (0.66/0.47)	116/81 (0.59/0.41)
38	Drawbar pull	Opt 3 stg FFL mast	ft/min (m/sec)	134/94 (0.68/0.48)	118/81 (0.6/0.41)
39	Brake	Opt 4 stg FFL mast	ft/min (m/sec)	136/94 (0.69/0.48)	
40	Gradeability	Std 2 stg FFL mast	ft/min (m/sec)	100/112 (0.51/0.57)	91/110 (0.46/0.56)
41	Drawbar pull	Opt 2 stg FFL mast	ft/min (m/sec)	91/106 (0.46/0.54)	73/102 (0.37/0.52)
42	Gradeability	Opt 3 stg FFL mast	ft/min (m/sec)	93/108 (0.47/0.55)	79/104 (0.4/0.53)
43	Gradeability	Opt 4 stg FFL mast	ft/min (m/sec)	77/91 (0.39/0.46)	
44	Gradeability	5 minute rating	%	39/33	36/28
45	Gradeability	60 minute rating	%	32/19	29/16
46	Drawbar pull	5 minute rating	ibf	3773/4926	3883/4830
47	Drawbar pull	60 minute rating	ibf	3208/2993	3181/2912
48	Brake	Method of control	Service/parking	Hydraulic / mechanical	
49	Brake	Method of operation	Service/parking	Foot / foot	
ELECTRIC				Lithium-ion	
39	Battery	Type		80	
40	Traction motor	60 minute rating	Volts	80	
41	Pump motor	15% rating	hp (kW)	31.6 (23.6)	
42	Traction motor	Type/control method	hp (kW)	32.2 (24)	
43	Pump motor	Type/control method		AC / transistor	
44	Number of speeds	Traction/pump		AC / transistor	
45	Step height			Infinitely variable / Infinitely variable	
46	Floor height	Lowest point	in (mm)	18.7 (475)	
47	Attachment relief pressure		in (mm)	27.4 (696)	
48	Auxiliary relief pressure	3rd and 4th function	psi (bar)	2250 (155)	
49	Sound level	Measured per ANSI B56.11.5	gal/min (l/min)	11 (40)	
50	Sound level		dB (A)	65	

NL = no load, RL = rated load

The following chargers are approved to use with the ERC050-060VGL lithium-ion battery:

- Posicharge ProCORE (80V) - 10kW, 15kW, 20kW or 30kW single cable
- EcoTec Fast Charge Access (80V) - 80-500-32FC or 80-650-32FC

Above specifications, unless otherwise listed, are for a standard truck without optional equipment.

Right angle stack and equal intersecting aisle are calculated using a 40" wide pallet.

MAST DIMENSIONS ERC050VGL

Maximum Fork Height (TOF)	Overall Lowered Height	Overall Extended Highest		Free Lift (TOF)		Approx. Total Wt. of Std. Equipped Truck
		w/ Load Backrest	w/o Load Backrest	w/ Load Backrest	w/o Load Backrest	ERC050VGL
in (mm)	in (mm)	in (mm)	in (mm)	in (mm)	in (mm)	lbs (kg)
2-STAGE LIMITED FREE LIFT (LFL) HI-VIS™₂ MAST						
125 (3192)	83 (2085)	174 (4415)	147 (3749)	5 (140)	5 (140)	9180 (4170)
133 (3392)	86 (2185)	182 (4615)	155 (3949)	5 (140)	5 (140)	9220 (4185)
1137 (3492)	88 (2235)	186 (4715)	159 (4049)	5 (140)	5 (140)	9240 (4195)
2-STAGE FULL FREE LIFT (LFL) HI-VIS™ MAST						
126 (3202)	83 (2085)	175 (4425)	148 (3759)	33 (862)	60 (1528)	9220 (4185)
133 (3402)	86 (2185)	183 (4625)	155 (3959)	37 (964)	64 (1628)	9260 (4205)
137 (3502)	88 (2235)	186 (4725)	159 (4059)	39 (1012)	66 (1678)	9280 (4215)
3-STAGE FULL FREE LIFT (LFL) HI-VIS™₂ MAST						
189 (4800)	83 (2085)	238 (6023)	210 (5399)	33 (862)	60 (1546)	9560 (4340)
194 (4950)	85 (2135)	243 (6173)	216 (5489)	36 (917)	62 (1596)	9580 (4350)
200 (5100)	88 (2235)	249 (6323)	222 (5639)	39 (1012)	66 (1696)	9630 (4370)
218 (5550)	94 (2385)	267 (6773)	239 (6089)	45 (1162)	72 (1846)	9720 (4415)
236 (6000)	102 (2585)	285 (7223)	257 (6539)	53 (1362)	80 (2046)	9910 (4500)
4-STAGE FULL FREE LIFT (LFL) HI-VIS™ MAST						
240 (6098)	84 (2133)	289 (7321)	263 (6678)	35 (910)	61 (1553)	10100 (4585)
252 (6404)	88 (2235)	301 (7627)	275 (6984)	39 (1012)	65 (1655)	10160 (4610)
264 (6710)	92 (2336)	313 (7933)	287 (7290)	43 (1113)	69 (1756)	10220 (4640)

MAST DIMENSIONS ERC060VGL

Maximum Fork Height (TOF)	Overall Lowered Height	Overall Extended Highest		Free Lift (TOF)		Approx. Total Wt. of Std. Equipped Truck
		w/ Load Backrest	w/o Load Backrest	w/ Load Backrest	w/o Load Backrest	ERC060VGL
in (mm)	in (mm)	in (mm)	in (mm)	in (mm)	in (mm)	lbs (kg)
2-STAGE LIMITED FREE LIFT (LFL) HI-VIS™₂ MAST						
118 (3009)	83 (2085)	167 (4237)	143 (3654)	5 (150)	5 (150)	10240 (4650)
126 (3209)	86 (2185)	175 (4437)	151 (3854)	5 (150)	5 (150)	10280 (4665)
130 (3309)	88 (2235)	179 (4537)	155 (3954)	5 (150)	5 (150)	10300 (4675)
2-STAGE FULL FREE LIFT (LFL) HI-VIS™ MAST						
118 (3010)	83 (2085)	167 (4237)	144 (3655)	33 (857)	56 (1440)	10280 (4665)
126 (3210)	86 (2185)	175 (4437)	151 (3855)	37 (957)	60 (1540)	10320 (4685)
130 (3310)	88 (2235)	179 (4537)	155 (3955)	39 (1007)	62 (1590)	10340 (4695)
3-STAGE FULL FREE LIFT (LFL) HI-VIS™₂ MAST						
175 (4468)	83 (2085)	225 (5696)	200 (5095)	33 (857)	57 (1458)	10610 (4815)
181 (4618)	85 (2135)	231 (5846)	206 (5245)	35 (907)	59 (1508)	10640 (4830)
187 (4768)	88 (2235)	237 (5996)	212 (5395)	39 (1007)	63 (1608)	10660 (4840)
205 (5218)	94 (2385)	254 (6446)	230 (5845)	45 (1157)	69 (1758)	10770 (4890)
223 (5668)	102 (2585)	272 (6896)	248 (6295)	53 (1357)	77 (1958)	10910 (4955)
4-STAGE FULL FREE LIFT (LFL) HI-VIS™ MAST						
240 (6098)	84 (2133)	289 (7321)	263 (6678)	35 (910)	61 (1553)	11000 (4995)
252 (6404)	88 (2235)	301 (7627)	275 (6984)	39 (1012)	65 (1655)	11060 (5020)
264 (6710)	92 (2336)	313 (7933)	287 (7290)	43 (1113)	69 (1756)	11120 (5050)

FEATURES LIST

STANDARD FEATURES

80V electrical system
80V @ 420Ah battery
2-stage limited free lift (LFL) Hi-Vis™2 mast with maximum fork height of 125" (3192mm) (ERC045-055VG) or 118" (4800mm) (ERC060-070VG)
5° forward and 5° back mast tilt
38.5" (980mm) wide Class II (ERC045-055VG) or Class III (ERC060-070VG) hook-type carriage with 38.5" (980 mm) high load backrest extension
42" (1067mm) long forks
Smooth tread rubber drive tire and steer tire
Premium Performance Package
Standard construction
12" steering wheel with integral spinner knob
Non-suspension vinyl seat
Black, non-cinch seat belt with Emergency Locking Retractor
Foot applied / hand released park brake
Key switch start
88.5" grid style overhead guard
Foot Direction Control Pedal
3-function hydraulic control valve
AC traction and pump motors (completely brushless)
Transistor drive and pump control
Advanced VSM (vehicle system manager)
Progressive thermal management system
Fully integrated CANbus communication
On-demand power steering
Continuous Stability System (CSS™)
Power assist braking
Auto Deceleration System (ADS) with regenerative braking
Multifunction display
- Battery state of charge with low battery lift interrupt
- Hour meter
- Performance mode indicator
- Fault indicator
- 4 operator selectable, programmable performance modes
Easy ingress/egress with low step height and contoured handhold
Operator convenience station - storage areas, beverage & clipboard holders
Accutouch electro-hydraulic mini-lever controls with fully adjustable armrest
Adjustable tilt steering column with low profile cowl
Cushioned floor mat
Static strap
Tow pin
Seatside power disconnect button
On-board software: program, test & diagnose; password protected
Electronic horn with integral relay (long life / no adjustments)
36 month / 6,000 hour powertrain warranty
12 month / 2,000 hour full truck warranty
84 month / 12,000 hour lithium-ion battery warranty
Operating manual

OPTIONAL FEATURES

Cooler/freezer package—operating temp: -20°F to +120°F
2-stage full free lift (FFL) Hi-Vis™ mast
-3-stage full free lift (FFL) Hi-Vis™2 mast
-4-stage full free lift (FFL) Hi-Vis™ mast
Carriage with integral sideshift
Carriage with integral sideshifting fork positioner
Attachment carriages
Mast tilt option – 10° forward / 5° back
Mast tilt option – 5° forward / 4° back
Return to set tilt
Air Ride suspension seat
Accumulator
4-function hydraulic control valve
Non-marking, rubber, or lug tread tires
Wide tread tires
Non-suspension seat (cloth)
Full-suspension seat (vinyl or cloth)
Full-suspension swivel seat (vinyl or cloth)
86.5" grid style overhead guard
84.1" flat plate overhead guard
88.5" drive-in rack grid style overhead guard
Keyless start (with auxiliary key switch)
Seatside directional control
Automatic electro-mechanical park brake
Telescopic steering column with tilt memory
LED and halogen work light packages
LED dome / reading light
Basic & premium LED brake/tail/back-up light packages
Key switch controlled lights
Audible alarm – reverse operation (manually adjustable to 87, 97 or 102 dB)
Visible amber strobe light - continuous activated, overhead guard mounted
Rear drive handle with integrated horn button
Mirrors – dual side view or panoramic
Load weight indicator
Impact monitor
Operator password
Operator daily checklist
System monitor – hydraulic low fluid level indicator and hydraulic filter service indicator
Hydraulic attachment extension tubes with quick disconnect fittings
Fire extinguisher – 2.5 lb. dry chemical
Synchronous steering
Red, high-visibility, non-cinch seat belt with or without start interlock
Low mount display

About Yale®



Yale Materials Handling Corporation is one of the oldest manufacturers of lift trucks in the world. We've been in the business of lifting since 1875 and we apply that experience to help customers solve materials handling challenges. Our full line of lift trucks range in capacity from 2,000 to 36,000 pounds and are powered by internal combustion engines or electric options. Yale also offers robotic solutions, telemetry, fleet management, parts, financing and training. From traditional lift truck equipment to emerging technologies, our goal, every day, is to work with our nationwide dealer network to continually improve and provide the solutions you need, when and how you need them.

MATERIALS HANDLING FOR:



3PL



Auto Parts
Distribution



Beverage



Cold & Frozen
Foods



Food
Distribution



Food
Processing



Furniture &
Furnishings



Health &
Pharma



Home
Centers



Printing &
Publishing



Retail &
E-Commerce

Yale Materials Handling Corporation

P.O. Box 7367
Greenville, NC 27835-7367
U.S.A.

www.yale.com

YALE,  and PEOPLE. PRODUCTS. PRODUCTIVITY, are trademarks, service marks or registered marks in the United States and certain other jurisdictions. © Yale Materials Handling Corporation 2021. All Rights Reserved.

Trucks may be shown with optional equipment. Truck performance may be affected by the condition of the vehicle, how it is equipped and the application. Specifications are subject to change without notice. Consult your Yale® Dealer if any of the information shown is critical to your application.

CERTIFICATION: Yale lift trucks meet the design and construction requirements of B56.1-1969, per OSHA Section 1910.178(a)(2), and also comply with the B56.1 revision in effect at time of manufacture.