



MP 30UX

Light-duty walkie
pallet jack

3,300 lbs.



MP30UX features

The Yale® MP30UX light-duty walkie pallet jack combines ergonomic features, reliable technology and energy efficiency in a cost-effective package for less-demanding applications. The simply efficient, low-maintenance solution is backed by the Yale brand and nationwide dealer network to meet productivity requirements and help reduce operational costs, day after day.



CONTROL HANDLE

Standard control handle offers left and right hand operation

PRODUCTIVITY

- Small turning radius 57.2" (1454mm)
- Performs well on gradients
- Long handle helps reduce steering effort
- Drive capability when tiller is upright, helps reduce turning space
- Entry rollers help facilitate fork entry
- Variable speed control
- Built-in charger
- Low speed switch in the handle
- Floating balance wheel automatically adjusts height and helps improve stability when unloading

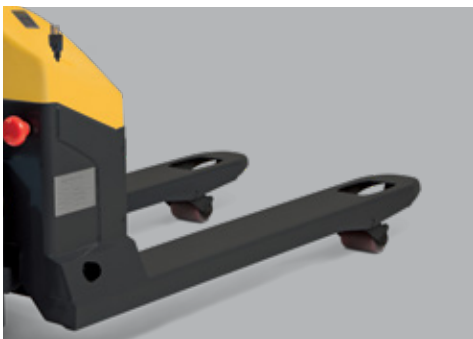

ENTRY ROLLERS HELP FACILITATE FORK ENTRY

SERVICEABILITY

- Fast and efficient servicing
- Simple components
- Computer-based diagnostics not required
- Sealed maintenance-free batteries
- Tandem wheel option available

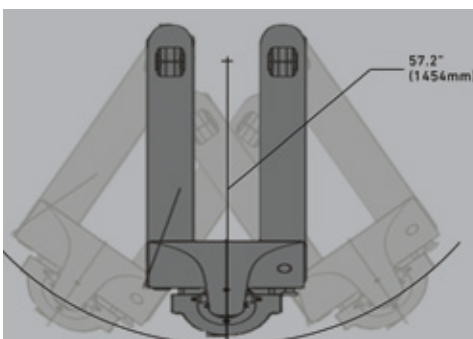

SMALL TURNING RADIUS

OPTIMUM STRUCTURAL DESIGN

- Formed heavy-gauge steel helps provide maximum fork strength and longevity
- Pull rod design helps protect against bending
- Durable plastic covers
- Compact and lightweight design

SAFETY FEATURES

- Emergency stop button
- Emergency reversing belly button
- Casters to help increase stability

GENERAL SPECIFICATIONS - MP30UX

GENERAL			
1	Power type		24-volt
2	Operator type		Pedestrian
3	Rated capacity	lb. (kg)	3300 (1500)
4	Load center	in. (mm)	23.6 (600)
5	Fork length	in. (mm)	45.28 (1150)
6	Fork overall width	in. (mm)	26.97 (685) / 20.47 (520)
7	Fork width (individual fork)	in. (mm)	6.30 (160)
8	Wheelbase (raised/lowered)	in. (mm)	50.67 (1287) / 53.42 (1357)
9	Overall length	in. (mm)	65.11 (1654)
10	Outside turning radius (raised)	in. (mm)	57.24 (1454)
11	Right angle stack (39.37 x 47.24 crossways)	in. (mm)	73 (1854)
12	Overall lift height - top of forks	in. (mm)	7.48 (190)
13	Lowered height - top of forks	in. (mm)	2.95 (75)
14	Total lift	in. (mm)	4.52 (115)
15	Truck overall width	in. (mm)	26.97 (685) / 22.12 (562)
16	Chassis length	in. (mm)	19.84 (504)
17	Height of tiller (max.)	in. (mm)	50 (1270)
18	Battery compartment - standard	in. (mm)	8.97 (228) / 5.43 (138) / 8.42 (214)
19	Maximum gradeability (loaded/unloaded)	%	5 / 10
20	Maximum travel speed (loaded/unloaded)	mph (km/h)	2.7 (4.3) / 3 (4.8)
21	Traction motor control method type		DC
22	Service brake type		Electric
23	Truck weight (approximate) with battery - NL/RL	lb. (kg)	451.95 (205) / 3758.9 (1705)
24	Drive tire - size type (number of wheels)	in. (mm)	Ø7.68 (195) x 2.75 (70) poly (1)
25	Load wheel - size/type (number of wheels)	in. (mm)	Ø2.91 (74) x 3.54 (90) Poly single Ø2.91 (74) x 2.75 (70) Poly tandem
26	Battery type		Sealed
27	Battery ampere hours	Ah	65
28	Battery weight	lb. (kg)	79.37 (36)
29	On board charger	V	100-240
30	Sound level at the drivers ear according to EN/DIN 12 053	dB (A)	<68

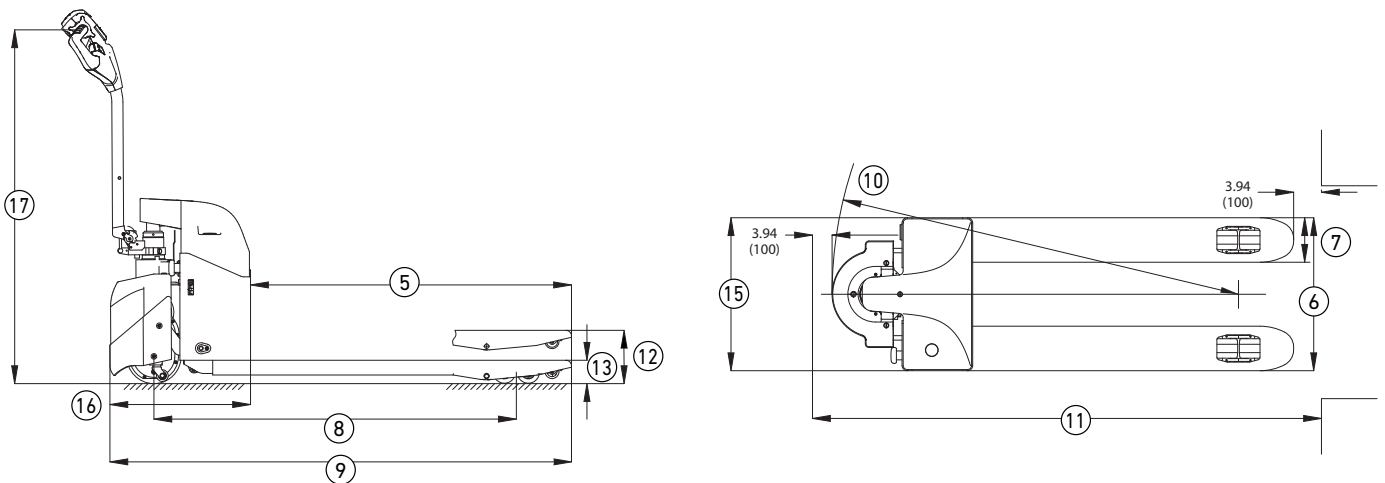

Circled truck dimensions correspond to the line numbers in the General Specifications chart. Dimensions are listed in inches (millimeters.)

About Yale

Yale Lift Truck Technologies leverages over a century of material handling experience and substantial investment in innovation to bring the most advanced technology-driven lift truck solutions to market. The company offers a full line of award-winning lift trucks, including reach trucks, order pickers, turret trucks, pallet jacks and trucks, pallet stackers, tow tractors and counterbalanced forklifts, as well as powerful operator assist solutions, proven robotics and a wide range of power sources to help customers adapt to today's demanding supply chain. Yale and its independent dealer network support these solutions with comprehensive after-sales service, parts, financing and training.



Yale Lift Truck Technologies
P.O. Box 7367
Greenville, NC 27835-7367
U.S.A.



EXPLORE MORE
ONLINE.
←

yale.com

© 2023 Hyster-Yale Group, Inc., all rights reserved. YALE and  are trademarks of Hyster-Yale Group, Inc.

Trucks may be shown with optional equipment and/or features not available in all regions. Truck performance may be affected by the condition of the vehicle, how it is equipped and the application. Specifications are subject to change without notice. Consult your Yale® Dealer if any of the information shown is critical to your application.

CERTIFICATION: Yale lift trucks meet the design and construction requirements of B56.1-1969, per OSHA Section 1910.178(a)(2), and also comply with the B56.1 revision in effect at time of manufacture.

MATERIALS HANDLING FOR:

Third-party logistics (3PL)

Auto parts distribution

Beverage

Cold & frozen foods

Food distribution

Food processing

Furniture & furnishings

Government

Health & pharma

Home centers & durables

Retail & e-commerce