

DC/EC Series

Diesel Powered Forklift Trucks

8,000kg, 9,000kg, 10,000kg, 12,000kg, 13,000kg, 14,000kg and 16,000kg

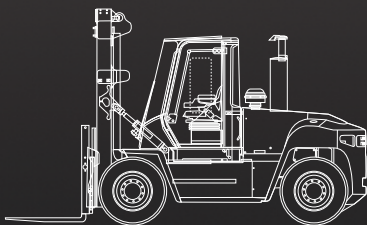

- Choice of Powertrain and Hydraulic configurations, to suit specific customer requirements.
- Load Sensing Hydraulics, with highly efficient 'variable displacement' pumps
- Nominal lifting capacities including side shift carriage - Full capacity up to 6200mm lift height
- New transmissions, with smooth auto-shift system, also featuring protective lock-out on forward-reverse shifting and engine and transmission protection systems as standard
- Fastest lifting speeds, with a practical average of up to 0.35 m/sec
- Excellent ergonomics with renowned Yale ERGO Cab

Yale 
People. Products. Productivity.™

Truck Dimensions

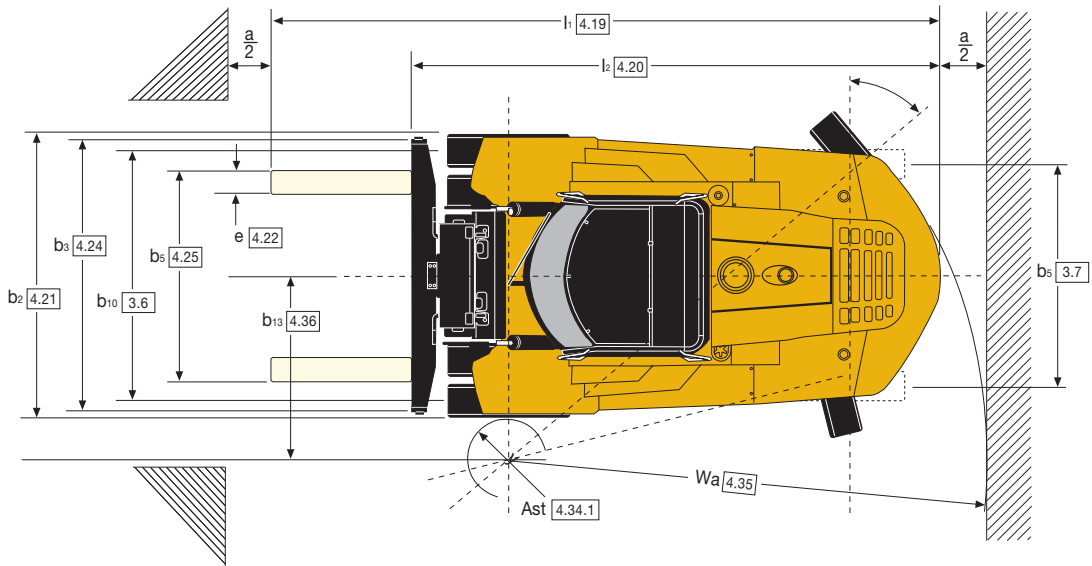
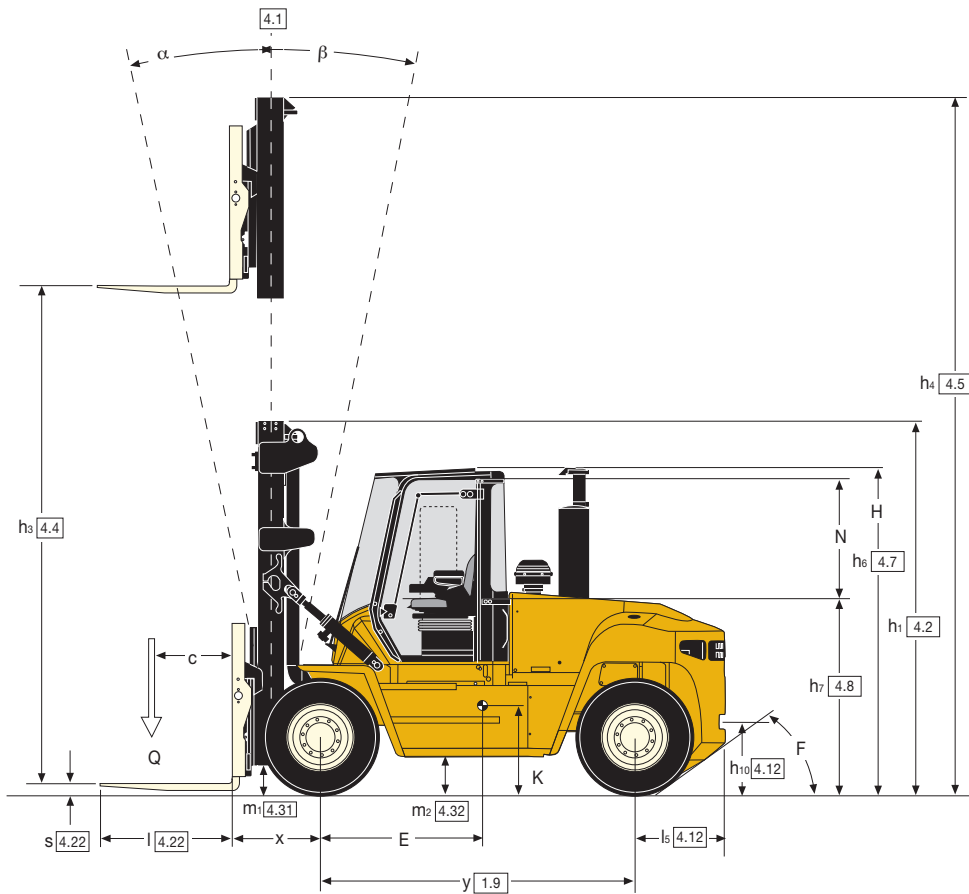

Rated capacities

Load Centre

Distance from forks to centre of gravity of load.

Rated Load

Based on vertical masts as shown in VDI table.

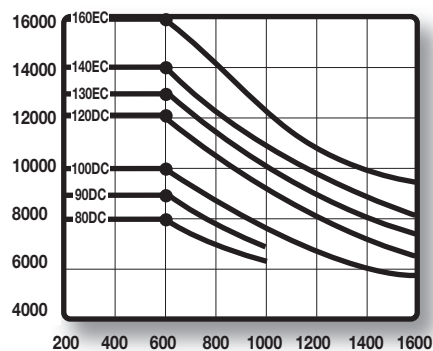

\odot = Centre of gravity of unladen truck
 $Ast = Wa + x + l_6 + a$ (if $b_{12/2} < b_{13}$)
 a = Minimum operating distance
 l_6 = load lengths
 b_{12} = load width
 (VDI-standard = 200 mm BITA recommendation = 300 mm)

Mast details and capacity ratings (kg) - Pneumatic tyres

Model					GDP 80 DC		GDP 90 DC		GDP 100 DCS	
Tyres					9.00 - 20 14PR		9.00 - 20 14PR		10.00 - 20 16PR	
Width across tyres					2425mm		2425mm		2448mm	
Mast	OAH h1	FFH h2+s	MFH h3+s	h4	Forks	Integral Sideshift	Forks	Integral Sideshift	Forks	Integral Sideshift
					600	600	600	600	600	600
					LC	LC	LC	LC	LC	LC
2-Stage LFL (V)	3329*	-	3750	5172*	8600	8000	9500	9000	10600	10000
	3779*	-	4650	6072*	8600	8000	9500	9000	10600	10000
	4155*	-	5400	6822*	8600	8000	9500	9000	10600	10000
3-Stage FFL (F)	3021*	1401	5600	7006*	7300	7080	8200	7980	9740	9180
	3154*	1534	6000	7406*	7160	6940	8060	7820	9680	9140
	3321*	1701	6500	7906*	6980	6760	7860	7640	9440	8900
	3487*	1867	7000	8406*	6780	6580	7640	7420	9180	8700

Mast details and capacity ratings (kg) - Pneumatic tyres

Model					GDP 100 DC		GDP 120 DC	
Tyres					10.00 - 20 16PR		10.00 - 20 16PR	
Width across tyres					2448mm		2448mm	
Mast	OAH h1	FFH h2+s	MFH h3+s	h4	Forks	Integral Sideshift	Forks	Integral Sideshift
					600	600	600	600
					LC	LC	LC	LC
2-Stage LFL (V)	3630	-	3750	5470	10450	10000	12700	12000
	4080	-	4650	6370	10450	10000	12700	12000
	4455	-	5400	7120	10450	10000	12700	12000
	4855	-	6200	7920	10450	10000	12700	12000
	5105	-	6700	8420	10300	9700	12400	11700
3-Stage FFL (F)	3045	1435	5600	7030	10060	9440	11420	10720
	3180	1570	6000	7430	9900	9280	11240	10560
	3345	1735	6500	7930	9680	9080	11020	10360
	3510	1900	7000	8430	9640	8860	10780	10140

Mast details and capacity ratings (kg) - Pneumatic tyres

Model					GDP 130 EC		GDP 140 EC		GDP 160 EC	
Tyres					12.00 - 20 16PR		12.00 - 20 16PR		12.00 - 20 16PR	
Width across tyres					2607mm		2607mm		2607mm	
Mast	OAH h1	FFH h2+s	MFH h3+s	h4	Forks	Integral Sideshift	Forks	Integral Sideshift	Forks	Integral Sideshift
					600	600	600	600	600	600
					LC	LC	LC	LC	LC	LC
2-Stage LFL (V)	3640	-	3750	5470**	13600	13000	15000	14000	16400	16000
	4090	-	4650	6370**	13600	13000	15000	14000	16400	16000
	4465	-	5400	7120**	13600	13000	15000	14000	16400	16000
	4865	-	6200	7920**	13600	13000	15000	14000	16400	16000
	5115	-	6700	8420**	13450	12700	14800	13800	16200	15800
3-Stage FFL (F)	3070	1300**	4400	6080**	12800	11940	13720	12820	15600	14620
	3270	1500**	5000	6680**	12740	11880	13660	12760	15540	14560
	3600	1830**	6000	7680**	12340	11520	13260	12380	15120	14160
	3940	2160**	7000	8680**	11760	10980	12680	11840	14520	13600

*Add 25mm if optional 10.00 x 20 tyres are fitted.

**Deduct 20mm for GDP130EC with 11.00 x 20 tyres.

Powertrains

	1.3	Drive: electric (battery or mains), diesel, petrol, LPG		Diesel	Diesel	Diesel
Engine	7.1	Engine manufacturer/type		Cummins QSB 6.7 Stage IIIA	Cummins QSB 4.5 Stage IIIB	Cummins QSB 6.7 Stage IIIB
	7.2	Engine power according to ISO1585 (nominal)	kW @rpm	116 @ 2300	119 @ 2300	122 @ 2300
	7.2.1	Engine power according to ISO1585 (maximum)	kW @rpm	116 @ 2300	122 @ 2200	125 @ 2200
	7.3	Rated speed	min ⁻¹	2300	2300	2300
	7.3.1	Torque (maximum)	Nm@rpm	597 @ 1500	624 @ 1500	732 @ 1500
	7.4	Number of cylinders/displacement	cm ³	6 / 6700	4 / 4500	6 / 6700
	7.5	Fuel consumption according VDI cycle	l/h	call	call	call
	Drive train	8.1	Type of drive unit		hydrodynamic 3 speed	hydrodynamic 3 speed
8.2		Transmission manufacturer/type		ZF / WG161	ZF / WG161	ZF / WG161
8.6		Wheel drive/drive axle manufacturer/type		Axle Tech / PRC 425	Axle Tech / PRC 425	Axle Tech / PRC 425
8.11		Service brake		oil-immersed / wet disc	oil-immersed / wet disc	oil-immersed / wet disc
8.12		Parking brake		dry disc on drive axle	dry disc on drive axle	dry disc on drive axle

VDI 2198 - General Specifications

		Yale		Yale		Yale			
		GDP 80 DC		GDP 90 DC		GDP 100 DCS			
Characteristics	1.1	Manufacturer (abbreviation)							
	1.2	Manufacturer's type designation							
	1.3	Drive: electric (battery or mains), diesel, petrol, LPG	Diesel		Diesel		Diesel		
	1.4	Operator type: hand, pedestrian, standing, seated, order-picker	Seat		Seat		Seat		
	1.5	Rated capacity/rated load	Q (kg)	8000	9000	10000			
	1.6	Load centre distance	c (mm)	600	600	600			
	1.8	Load distance, centre of drive axle to fork	x (mm)	785	785	819			
	1.9	Wheelbase	y (mm)	2700	2700	2700			
	Weights	2.1	Service weight	kg	12413	12748	15287		
2.2		Axle loading, laden front/rear	kg	19132	1881	20585	1720	23144	2107
2.3		Axle loading, unladen front/rear	kg	6304	6109	6288	6460	7943	7344
Wheels and Tyres	3.1	Tyres: L=pneumatic, V=solid, SE=pneumatic-shaped solid	L		L		L		
	3.2	Tyre size, front	9.00-20 14PR		9.00-20 14PR		10.00-20 16PR		
	3.3	Tyre size, rear	9.00-20 14PR		9.00-20 14PR		10.00-20 16PR		
	3.5	Wheels, number front/rear (x = driven wheels)	4X / 2		4X / 2		4X / 2		
	3.6	Tread, front	b10 (mm)	2190	2190	2190			
	3.7	Tread, rear	b11 (mm)	1930	1930	1930			
	Dimensions	4.1	Tilt of mast/fork carriage, forward α /backward β	degrees	15 / 12	15 / 12	15 / 12		
4.2		Height, mast lowered	h1 (mm)	4155	4155	4455			
4.3		Free lift ▼	h2 (mm)	0	0	0			
4.4		Lift ▼	h3 (mm)	5339	5339	5346			
4.5		Height, mast extended +	h4 (mm)	6822	6822	7118			
4.7		Height of overhead guard (cabin) ○	h6 (mm)	3015	3015	3035			
4.8		Seat height/stand height ✕	h7 (mm)	1742	1742	1762			
4.12		Coupling height	h10 (mm)	635	635	655			
4.17		Overhang	l5 (mm)	809	809	809			
4.19		Overall length	l1 (mm)	5514	5514	5548			
4.20		Length to face of forks	l2 (mm)	4294	4294	4328			
4.21		Overall width	b2 (mm)	2425	2425	2448			
4.22		Fork dimensions ISO2331	s/e/l (mm)	65 / 200 / 1220	65 / 200 / 1220	75 / 200 / 1220			
4.23		Fork carriage ISO 2328, class/type A, B		75mm pin type	75mm pin type	75 mm pin type			
4.24		Fork carriage width ▶	b3 (mm)	2350	2350	2350			
4.25		Distance between fork-arms	b5 (mm)	520 - 2230	520 - 2230	520 - 2230			
4.30		Reach, lateral from vehicle centerline*	b8 (mm)	150	150	150			
4.31		Ground clearance, laden, below mast	m1 (mm)	248	248	225			
4.32		Ground clearance, centre of wheelbase	m2 (mm)	274	274	292			
4.34.1		Aisle width with pallets 1200mm long x 1200mm crossways	Ast (mm)	6099	6099	6133			
4.35	Turning radius (outer)	Wa (mm)	3914	3914	3914				
4.36	Internal turning radius	b13 (mm)	1433	1433	1432				
Performance	5.1	Travel speed, laden/unladen Stage IIIA engine	km/h	30.2	31.0	30.2	31.0	30.6	31.2
		Travel speed, laden/unladen Stage IIIB engine	km/h	30.2	31.0	30.2	31.0	30.6	31.2
	5.2	Lifting speed, laden/unladen Stage IIIA engine	m/sec	0.47	0.51	0.47	0.51	0.36	0.39
		Lifting speed, laden/unladen Stage IIIB engine	m/sec	0.49	0.51	0.47	0.51	0.37	0.39
	5.21	Lifting speed, laden/unladen (120 ccm) Stage IIIA engine	m/sec	0.55	0.69	0.55	0.69	0.42	0.52
		Lifting speed, laden/unladen (120 ccm) Stage IIIB engine	m/sec	0.57	0.69	0.57	0.69	0.44	0.52
	5.3	Lowering speed, laden/unladen Stage IIIA engine	m/sec	0.50	0.48	0.50	0.48	0.50	0.48
		Lowering speed, laden/unladen Stage IIIB engine	m/sec	0.50	0.48	0.50	0.48	0.50	0.48
	5.5	Drawbar pull, laden/unladen Stage IIIA engine	kN	104.6	36	104.4	36.5	99.8	41.4
		Drawbar pull, laden/unladen Stage IIIB engine	kN	104.6	36	104.4	36.5	99.8	41.4
	5.7	Gradeability, laden/unladen Stage IIIA engine	%	63	32	57	31	46	31
Gradeability, laden/unladen Stage IIIB engine		%	63	32	57	31	46	31	
5.9	Acceleration time, laden/unladen Stage IIIA engine	s	5.5	4.7	5.6	4.8	6.2	5.3	
	Acceleration time, laden/unladen Stage IIIB engine	s	5.3	4.6	5.4	4.7	6.0	5.1	
5.10	Service brake		oil-immersed / wet disc		oil-immersed / wet disc		oil-immersed / wet disc		
Additional Data	10.1	Operating pressure for attachments	bar	193	193	193			
	10.2	Oil volume for attachments	l/min	100	100	100			
	10.3	Hydraulic oil tank, capacity	l	100	100	100			
	10.4	Fuel tank, capacity	l	128	128	128			
	10.5	Steering design		Hydrostatic		Hydrostatic		Hydrostatic	
	10.6	Number of steering rotation		3.7		3.7		3.7	
	10.7	Sound pressure level at the driver's seat	dB(A)	73		73		73	
	10.7.1	Sound power level during the working cycle	dB(A)	108		108		107	
10.8	Towing coupling, type DIN		yes / Pin		yes / Pin		yes / Pin		

▼ Bottom of forks.

✕ Full Suspension seat in depressed position.

+ Without load backrest.

▶ Add 50mm with load backrest.

○ +/- 3% tolerance depen on tyre pressure / or tyre brand.

Yale		Yale		Yale		Yale		Yale		Characteristics
GDP 100 DC		GDP 120 DC		GDP 130 EC		GDP 140 EC		GDP 160 EC		
Diesel		Diesel		Diesel		Diesel		Diesel		
Seat		Seat		Seat		Seat		Seat		
10000		12000		13000		14000		16000		
600		600		600		600		600		
819		819		896		896		896		
2900		2900		3300		3300		3300		
15180		16034		18429		19064		20119		Weights
22808	2336	25706	2301	29391	2121	30768	2336	33613	2517	
7969	7211	7875	8159	10376	8053	10364	8700	10343	9776	
L		L		L		L		L		Wheels and Tyres
10.00-20 16PR		10.00-20 16PR		12.00-20 16PR		12.00-20 16PR		12.00-20 16PR		
10.00-20 16PR		10.00-20 16PR		12.00-20 16PR		12.00-20 16PR		12.00-20 16PR		
4X / 2		4X / 2		4X / 2		4X / 2		4X / 2		
2190		2190		2276		2276		2276		
1930		1930		2000		2000		2000		
15 / 12		15 / 12		15 / 12		15 / 12		15 / 12		Dimensions
4455		4455		4466		4466		4466		
0		0		0		0		0		
5346		5346		5310		5310		5310		
7118		7118		7120		7120		7120		
3035		3035		3064		3064		3064		
1762		1762		1791		1791		1791		
653		653		684		684		684		
809		809		809		809		809		
5748		5748		6225		6225		6225		
4528		4528		5005		5005		5005		
2448		2448		2607		2607		2607		
75 / 200 / 1220		75 / 200 / 1220		90 / 200 / 1220		90 / 200 / 1220		90 / 200 / 1220		
75 mm pin type		75 mm pin type		85 mm pin type		85 mm pin type		85 mm pin type		
2350		2350		2500		2500		2500		
520 - 2230		520 - 2230		520 - 2380		520 - 2380		520 - 2380		
150		150		200		200		200		
225		225		178		178		178		
292		292		346		346		346		
6333		6333		6880		6880		6880		
4111		4111		4584		4584		4584		
1475		1475		1754		1754		1754		
30.6	31.2	30.5	31.1	26.6	28.0	26.6	28.0	26.3	27.3	Performance
30.6	31.2	30.5	31.1	26.6	28.0	26.6	28.0	26.3	27.9	
0.36	0.39	0.36	0.39	-	-	-	-	-	-	
0.37	0.39	0.37	0.39	-	-	-	-	-	-	
0.42	0.52	0.42	0.52	0.34	0.41	0.34	0.41	0.34	0.41	
0.44	0.52	0.45	0.52	0.36	0.41	0.36	0.41	0.36	0.41	
0.50	0.48	0.50	0.48	0.50	0.48	0.50	0.48	0.50	0.48	
0.50	0.48	0.50	0.48	0.50	0.48	0.50	0.48	0.50	0.48	
99.8	41.4	99.2	44.9	118.6	51.4	113.4	52.9	113	53.8	
99.8	41.4	99.2	44.9	118.6	51.4	113.4	52.9	113	53.8	
46	31	38	30	45	33	38	33	35	31	
46	31	38	30	45	33	38	33	35	31	
6.2	5.3	6.2	5.3	6.3	5.4	6.2	5.5	6.5	5.6	
6.0	5.1	6.1	5.2	6.1	5.3	6.2	5.4	6.3	5.5	
oil-immersed / wet disc		oil-immersed / wet disc		oil-immersed / wet disc		oil-immersed / wet disc		oil-immersed / wet disc		
193		193		193		193		193		
100		100		100		100		100		
100		100		140		140		140		
128		128		128		128		128		
Hydrostatic		Hydrostatic		Hydrostatic		Hydrostatic		Hydrostatic		Additional Data
3.7		3.7		3.7		3.7		3.7		
73		73		73		73		73		
107		107		107		107		107		
yes / Pin		yes / Pin		yes / Pin		yes / Pin		yes / Pin		

DC/EC Series

Models: GDP80DC, 90DC, 100DC, 100DCS, 120DC, GDP130EC, 140EC, 160EC

The DC/EC series offers superior traction, gradeability and drawbar pull. These trucks offer the productive travel / lift speeds and excellent manoeuvrability to meet the demands of tough applications (lumber, pipe, pre-stressed concrete, block/brick, stevedoring and heavy cargo). Special attachments may be required for the applications mentioned above.

ERGO Operator Compartment

Yale's ERGO Operator Compartment is ergonomically designed for maximum operator productivity.

Standard features:

- Full-length handrails
- Three non-slip entry steps
- Open floor with low front dash
- Dash instrument panel positioned to the right of driver, with gauges, warning lights and LCD message centre, switches, key start and park brake
- Two way adjustable steering column for height and tilt angle
- Inch brake/brake/accelerator pedal arrangement
- Custom moulded floor mat
- Angled overhead guard bars
- 3-way adjustable right hand armrest
- Wide angle side view mirrors
- Blinking red warning lights on steering column advise driver to refer to instrument panel
- Paddle lever actuators for hydraulic functions and combination paddle/rocker switches for optional attachments
- Joystick or lever controls.
- A full suspension vinyl seat

Optional enclosed cab option features:

- Curved tempered front and rear glass
- Twin arm single 990mm blade front wiper, rear wiper and top wiper with washer fluid spray
- Ten high capacity outlet vents for heating
- Optional air conditioning, or high capacity air-conditioning, with or without climate control
- Under cab sound insulation
- Cab filter for all incoming air
- Front and rear screen demisting

- Top cover laminated glass
- Storage bins

Other Features:

- A revised dash display which shows ZF WG161 transmission and hydraulic controller error codes.
- The entire operator cabin tilts manually or electrically for complete service access to major powertrain components.

Stage IIIA engines:

This diesel engine conforms to Stage IIIA emission standards and will be supplied into markets where the NRMM (Non Road Mobile Machinery) Stage IIIB legislation does not apply.

Cummins QSB 6.7L

The 6-cylinder in-line engine delivers maximum 116kW (155Hp) output at 2300rpm, offering extra durability for long periods of peak power operation.

Smooth torque of 597Nm at 1500rpm provides excellent acceleration and pulling power.

Stage IIIB engine:

For use mainly within EU (European Union) countries, trucks with Stage IIIB diesel engines have significantly reduced exhaust gas emissions. Also by applying Yale Intelligent Design criteria, these trucks are not only cleaner running but also more economical, achieving up to a 20% fuel saving.

Engines

Stage IIIA

- Cummins QSB6.7 Diesel engine
- ZF WG161 transmission
- Oil immersed 'wet disc' brakes
- Single/Dual VDP hydraulic pump *

Stage IIIB 8-12

- Cummins QSB4.5 Diesel engine
- ZF WG161 transmission
- Dry drum brakes with air dryer
- Single/Dual VDP hydraulic pumps *

Stage IIIB 13-16

- Cummins QSB6.7 Diesel engine
- ZF WG161 transmission
- Oil immersed 'wet disc' brakes
- Single/Dual VDP hydraulic pumps *

Cummins QSB 4.5L

The 4-cylinder in-line engine delivers max 122kW (160Hp) output at only 1900rpm, offering extra durability for long periods of peak power operation.

Smooth torque of 624Nm at 2200rpm provides excellent acceleration and

lugging power.

Cummins QSB 6.7L

The 6-cylinder in-line engine delivers max 125kW (170Hp) output at only 1900rpm, offering extra durability for long periods of peak power operation.

Smooth torque of 732Nm at 1500rpm provides excellent acceleration and lugging power.

Powertrain and Hydraulic Configurations

The range of Powertrain and Hydraulics configurations is designed to suit the requirements of specific customer and application needs, enabling operators to focus on lowering ownership costs and increasing productivity.

** 8-12t models have a single hydraulic pump as standard, the dual pumps are an option. 13-16t models have the dual hydraulic pumps as standard.*

Transmissions

All models feature the new ZF 3WG161 transmission, which is designed for more intensive applications, and delivers increased cooling performance, thanks to a heavy duty transmission oil pump (100L/min at 2000rpm), which ensures sufficient cooling oil flow for the clutches and torque converter.

The transmission features a stiffer torque converter and optimised shift points, which contribute to increased efficiency and results in a 5% lower fuel consumption. Lower noise emissions from the ZF transmission are achieved through the use of helical high contact gears.

A transmission is fitted with an automatic gear-change system with a column-mounted lever or optional FDC pedal for direction changes. Extremely smooth shifting and a forward-reverse shifting lock-out function are standard features.

Power on Demand

The load-sensing hydraulic system provides hydraulic lifting power proportional to the load being lifted. The load-sensing variable-displacement (VDP) pumps ensure that the engine supplies power to the hydraulic pumps only when required. This means that more engine power is available for driving, delivering increased responsiveness and acceleration for increased productivity.

This also delivers 5% increase in fuel efficiency, so reducing overall operating costs and including the

DC/EC Series

Models: GDP80DC, 90DC, 100DC, 100DCS, 120DC, GDP130EC, 140EC, 160EC

efficiency saving by the ZF transmission. In total this represents a fuel saving of 10%.

Three pre-defined user modes (smooth, medium, direct) can be selected through the user interface. These modes allow fine-tuning of the hydraulic controls, to achieve the best balance for the operator and the application.

Hydraulics

The load-sensing hydraulic system delivers faster laden lift speeds and increased auxiliary hydraulic speeds for optimum productivity, especially when using attachments.

Leak-free ORFS (O-ring) type fittings are used throughout the truck and the hydraulic oil tank is equipped with an external sight glass for oil level.

Hydraulic oil is effectively filtered at three locations in the system. The filter system uses a full-flow return line filter with 10 micron cartridge on the main system and is designed to maintain a high cleanliness level, ensuring reliable and durable performance.

- 8-12t models also have the single 90cc VDP pump, with a lifting performance well suited to the practical needs in most applications. Optionally available are Dual 60cc VDP pumps (2x60cc per revolution, max. pump performance 262 l/min) providing up to 30% higher laden lifting speeds.
- 13-16t models feature dual 60cc VDP pumps (2x60cc per revolution, max. pump performance 262 l/min).

Protection Systems

The engine, transmission and hydraulic protection systems monitor operating temperatures and pressures, and are designed to ensure the highest level of truck reliability and prevent unplanned downtime, for maximum productivity. The systems initially derate the engine power and finally (on engine and transmission protection) shut the engine down.

- The engine protection system monitors coolant temperature, air intake temperature and oil pressure.
- The transmission protection system monitors pressure, temperature and forward / reverse lockout on direction changes.
- The hydraulic protection system monitors low oil temperature. High

oil temperature protection is an optional extra.

Cooling System

The Quad-Cooler radiator contains four separate cooling cores for the engine, transmission, hydraulics and charge air cooler. The truck is designed to operate in ambient temperatures of -18° C up to 50° C in normal applications, or up to 45° C for heavy duty operations. The cooling air-intake is located at the top of the counterweight, to provide a cleaner air-flow.

Drive Axle

The wide AxleTech PRC-425 (8-12t) or PRC- 775 (13-16t) drive axle delivers excellent sideways stability and long-term durability thanks to the fitment of strong end-reduction shafts and gears.

All models feature oil-immersed brakes on the drive axle, which are oil cooled for durability and are virtually maintenance free. The parking brake is a dry disc brake on the drive axle input shaft, which is spring applied and hydraulically released

Steer Axle

The hydrostatic steer axle features a double-acting, single steering cylinder with adjustable end stops. It is renowned for its long lifespan and low maintenance requirements. Load-sensing power steering ensures low-effort operation under all operating conditions

Chassis

A rugged unitised frame structure is designed for tough, demanding applications and offers excellent stability. All nominal capacities are rated to include the sideshift carriage and the mast is mounted to the frame, not the drive axle. The DC/EC series has been designed to handle loads to high lift heights and there is no reduced capacity up to and including 6200 mm.

Masts

Yale Hi-Vis™ Simplex and Triplex masts afford operators outstanding visibility. Nested channel design incorporates full-face load rollers and side bearing blocks for durability and lateral rigidity. Rolled mast channels with a generous overlap and formed cross-members provide high strength. The leaf-type chain provides superior strength.

Carriage

The standard carriage is a pin type, 2350mm or 2500mm wide and is

equipped with four angled load rollers. It is an integral piece of the rugged front-end construction and offers excellent visibility. A wide range of carriages is available to suit all applications including non-sideshift, sideshift and individual or simultaneous fork-positioning

Brakes

Oil-immersed 'wet disc' brakes are standard and contribute to increased productivity and reduced ownership costs

Electrics

The truck features a 24 Volt system with 70A alternator and CANbus connection in the operator cab, for engine, transmission, hydraulics and instruments cluster. The LCD display with diagnostics for engine, transmission and electrical systems quickly identifies service needs.

Lights

2 mast mounted work lights, 2 rear cab-mounted work lights, 2 front marker lights, LED direction indicators, stop, tail and reverse lights.

Serviceability

The DC/EC is easily accessible with unobstructed access to the engine compartment and key components, thanks to the sideways-tilting cab and the 'gull-wing' style hood doors. Conveniently located service check points, as well as centralised, PC accessible diagnostics and CANbus connections (for engine, transmission, hydraulics and instruments) help to reduce fault identification time.

Truck downtime can also be reduced thanks to clean electrical and hydraulic routings plus O-Ring Face Seals are used throughout to eliminate hydraulic leaks. Virtually maintenance free Oil-immersed 'wet disc' brakes are available on all models.

Longer service intervals increase uptime and reduce servicing costs - Load Sensing Hydraulics oil change interval is extended up to 6,000 hours from 2,000 hours.

All models' transmission oil change interval is extended to 2,000 hours from 1,000 hours.

Stage III B engine models additional features:

Auto Rev-Up: During lifting and tilting, the engine speed is automatically increased in relation to the joystick/lever position. This feature is

DC/EC Series

Models: GDP80DC, 90DC, 100DC, 100DCS, 120DC, GDP130EC, 140EC, 160EC

active when the transmission is in neutral and inching mode.

Drive Over Lift (DOL): Priority is given to driving and fitting at the same time. The hydraulic performance is reduced while driving. Hydraulic performance is automatically increased when engine speed (engine torque) increases. This feature ensures smooth truck operation under all conditions and assists in reducing operator fatigue.

High performance Mode (HiP):

Selects the engine power mode. In the HiP mode the maximum power and torque is available for hydraulic and drive functions..

Economy Mode (ECO-eLo): With a key switch the ECO-eLo engine power mode is enabled. Throttle reaction is less aggressive which saves the fuel. The maximum RPM is reduced to 2000RPM, the duty cycle time is slightly impacted in this mode.

Alternate idle mode: The engine RPM is automatically reduced to stand-by mode if no functions are used for 30 seconds. Stage IIIB engine normal idle is 900RPM (QSB4.5), 850 (QSB6.7), in alternate idle mode 800RPM (QSB4.5), 750RPM (QSB6.7).

Optional Equipment

- Air conditioning
- High performance air conditioning
- Climate control air conditioning
- Enclosed cab
- High backrest on seat
- DeLuxe air suspension seat
- Trainer seat
- Reading light in the cab
- Sun shade: sliding screen under top window of cab
- Extra air re-circulation fan, inside the cab
- Converter: 24 Volt DC to 12 Volt DC, to use 12 V accessories, with a 'cigarette lighter' socket on the dash panel
- Storage box, lockable in the cab, behind the seat, for storing equipment, tools, etc. Internal 58cm wide x 17cm deep x 17-25cm high.
Note: Not available with Trainer seat



- Engine block heater, for cold climates
- Electric-powered tilting cab for more convenient service access
- Lifting eyes (2 x on mast and 2 x on rear counterweight)
- Radial pneumatic tyres
- Solid (pneumatic shaped) tyres
- Foot Directional Control pedal
- Joystick hydraulic control
- Hydraulic oil high temperature warning and protection system
- 24/12 volt DC-DC converter
- Various light kits
- Application specific masts (2-Stage Limited Free Lift, 2-Stage Full Free Lift, 3-Stage Full Free Lift), carriages and forks Hydraulic accumulator
- Travel speed limiter
- Back-up alarm (self-adjustable to 5dB above ambient)
- Special RAL colours
- Various attachments: Coil ram, paper roll clamp, etc.
- Raised cab position 500mm
- Mast tilt kits: (standard is 15° forward and 12° back) 20.5° forward and 7° back, or 5° forward and 12° back, or 15° forward and 10° back



- Protection rings on the rear steering wheels (to protect the wheel studs and nuts)
- Empty seat shutdown feature with variable time (3-15 minutes) delay. Saves fuel.
- Battery Master Switch, to disconnect the battery. Accessible from outside, mounted on the left-hand battery compartment.



NACCO Materials Handling Limited trading as Yale Europe Materials Handling
Flagship House, Reading Road North, Fleet, Hampshire GU51 4WD, United Kingdom.
Tel: + 44 (0) 1252 770700 Fax: + 44 (0) 1252 770784
www.yale-forklifts.eu

Country of Registration: England. Company Registration Number: 02636775



Safety. This truck conforms to the current EU requirements. Specification is subject to change without notice.

Publication part no. 258985414 Rev.01 Preliminary
Printed in The United Kingdom (0712HG) EN

Yale is a registered trade mark.
© Yale Europe Materials Handling 2012. All rights reserved.

Truck shown with optional equipment