



UX SERIES

BROCHURE

MP20UX
Electric Walkie
Pallet Truck

2,000kg

MP20UX

The Yale® electric walkie pallet truck MP20UX demonstrates cutting-edge design and reliable technology to facilitate operational needs. The low-maintenance helps increase productivity and reduces operational costs.

STANDARD FEATURES

- Brushless maintenance free AC motor
- Sealed maintenance free batteries
- Small turning radius 1335mm-1405mm (width 520/550/685mm)
- Self-adjusting caster wheels
- Drive capability when tiller is upright, greatly reducing turning space
- Tiller head with max. speed limit button
- Emergency stop and belly button
- Casters to increase stability
- Exit roller
- BDI and hour meter
- Built-in charger

OPTIONS

- External charger
- Various fork widths and lengths available



Handle (Standard)
(Left & Right Handed)



Entry Roller for
Easy Operation

TURNING RADIUS

The MP20UX has a small turning radius. When switched to low speed it adapts to narrow spaces. Ideal for shipping containers and tail gate applications.

MINI TYPE PALLET TRUCK

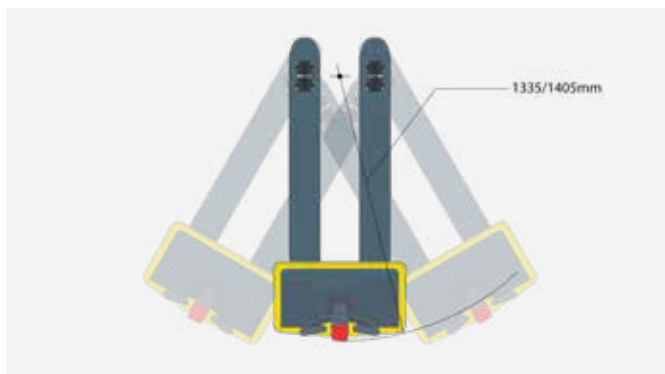

HAND PALLET TRUCK

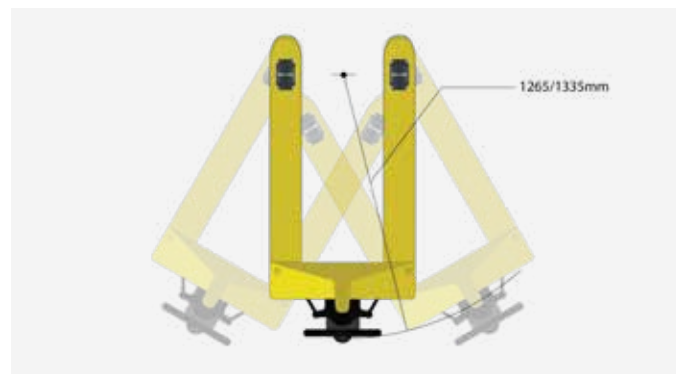

SPECIFICATIONS AND DIMENSIONS

Model	Measurement	MP20UX
Load capacity	Q (kg)	2000
Load centre distance	c (mm)	600
Wheelbase	y (mm)	1130
Fork height, lowered	h13 (mm)	85/75
Tyre size, front	mm	195x70
Tyre size, rear (single)	mm	80x93/74x93
Tyre size, rear (double)	mm	80x70/74x70
Wheels number front rear (x = driven wheels)		1X-2/4
Max. lift height	h3 (mm)	190/180
Height of tiller in drive position min./max.	h14 (mm)	950/1310
Overall length	l1 (mm)	1525/1595
Length to face of forks	l2 (mm)	375
Overall width	b1 (mm)	685
Fork dimensions	s/e/l (mm)	53/160/1150 (1220)
Width overall forks	b5 (mm)	520/550/685
Aisle width for pallets 1000x1200 (1200 crossways)	Ast (mm)	1725/1795
Aisle width for pallets 800x1200 (1200 lengthways)	Ast (mm)	1775/1795
Turning radius	Wa (mm)	1335/1405
Drive motor power	kW	0.9
Lift motor power	kW	0.8
Sound level at the driver's ear according to DIN12503	dB (A)	70
Travel speed, laden/unladen	Km/h	4/4.5
Battery voltage/nominal capacity K20	V/Ah	24/105
Battery dimensions l/w/h	mm	260/169/215
Battery weight	Kg	49
Service weight (with battery)	Kg	250

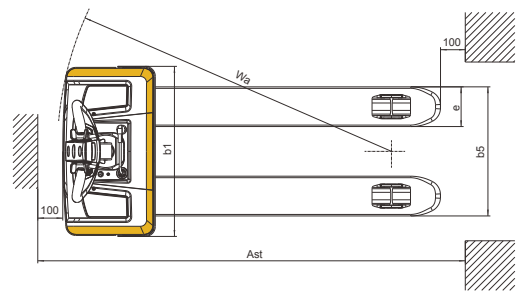
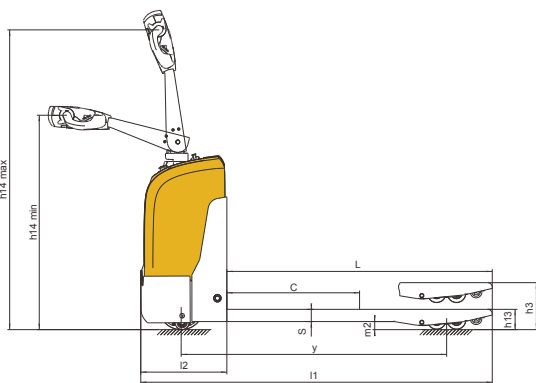

MP20UX POWER PLUG TYPE



A
Power Plug



F
Power Plug



G
Power Plug

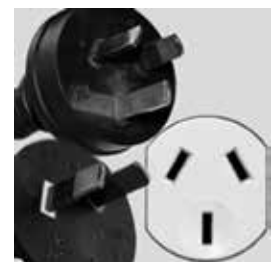

I
Power Plug

About Yale



Yale Lift Truck Technologies leverages over a century of material handling experience and substantial investment in innovation to bring the most advanced technology-driven lift truck solutions to market. The company offers a full line of award-winning lift trucks, including reach trucks, order pickers, turret trucks, pallet jacks and trucks, pallet stackers, tow tractors and counterbalanced forklifts, as well as powerful operator assist solutions, proven robotics and a wide range of power sources to help customers adapt to today's demanding supply chain. Yale and its independent dealer network support these solutions with comprehensive after-sales service, parts, financing and training.

Yale Lift Truck Technologies is a trading name of Hyster-Yale Asia-Pacific Pty Ltd., a wholly owned subsidiary of Hyster-Yale Materials Handling, Inc. (NYSE:HY) which is headquartered in Cleveland, Ohio and operates globally.

MATERIALS HANDLING FOR:

3PL

Auto Parts Distribution

Beverage

Cold & Frozen Foods

Food Distribution

Food Processing

Furniture & Furnishings

Government

Health & Pharma

Home Centers

Retail & E-commerce

Yale Pacific

1/23 Rowood Road, Prospect NSW 2148

Tel: +61 (2) 9795 3800 | Fax: +61 (2) 9792 8484

Yale Asia

16 Tuas Avenue 20, Singapore 638827

Tel: +65 6863 3387 | Fax: +65 6863 3349

yale.com

© 2023 Hyster-Yale Group, Inc., all rights reserved. YALE and  are trademarks of Hyster-Yale Group, Inc. Trucks may be shown with optional equipment and/or features not available in all regions. Specifications and details in this brochure are subject to change without prior notification.