



NR/NDR 030-040DC

SPEC SHEET

Pantograph
reach truck

3,000-4,000 lbs.

TRUCK DIMENSIONS - NR035-040DC

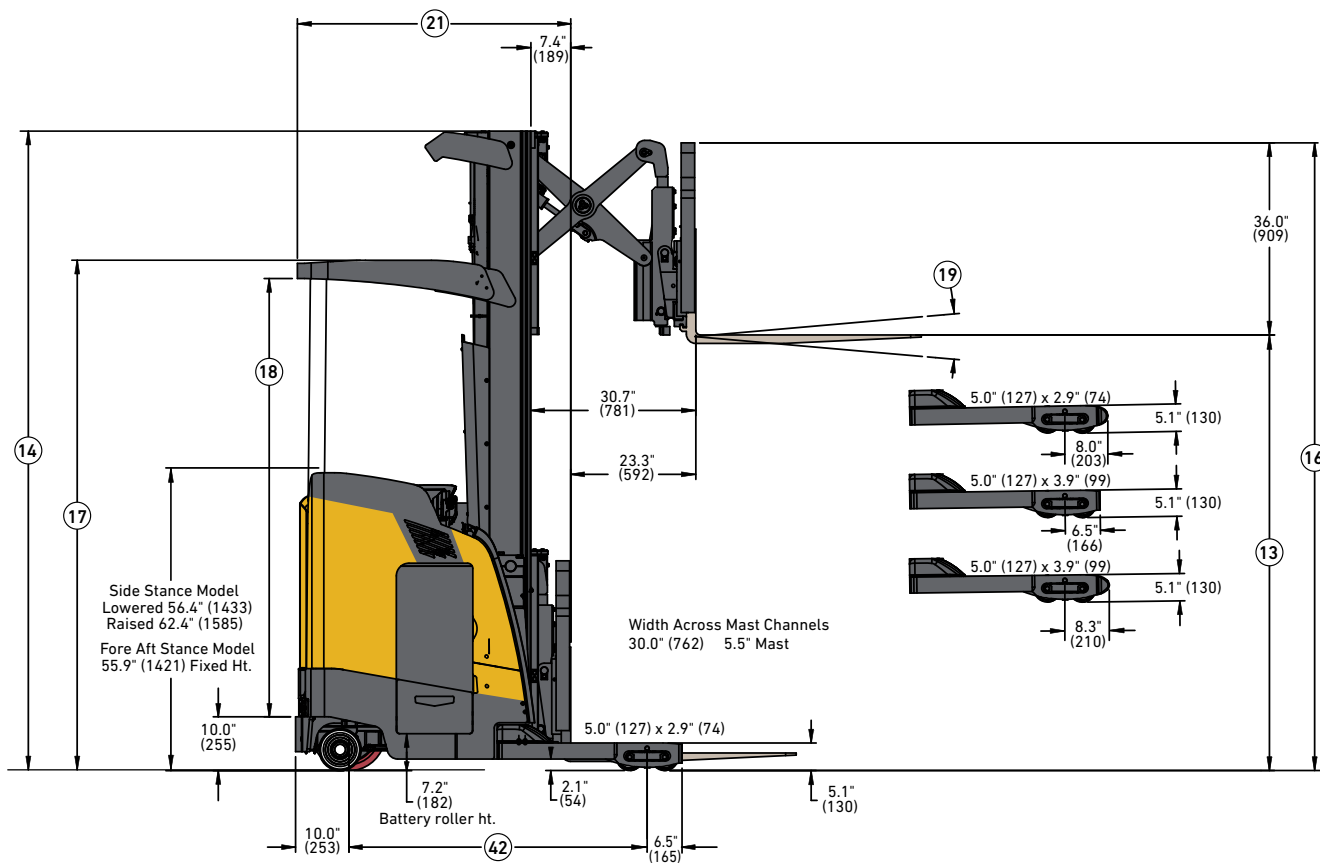
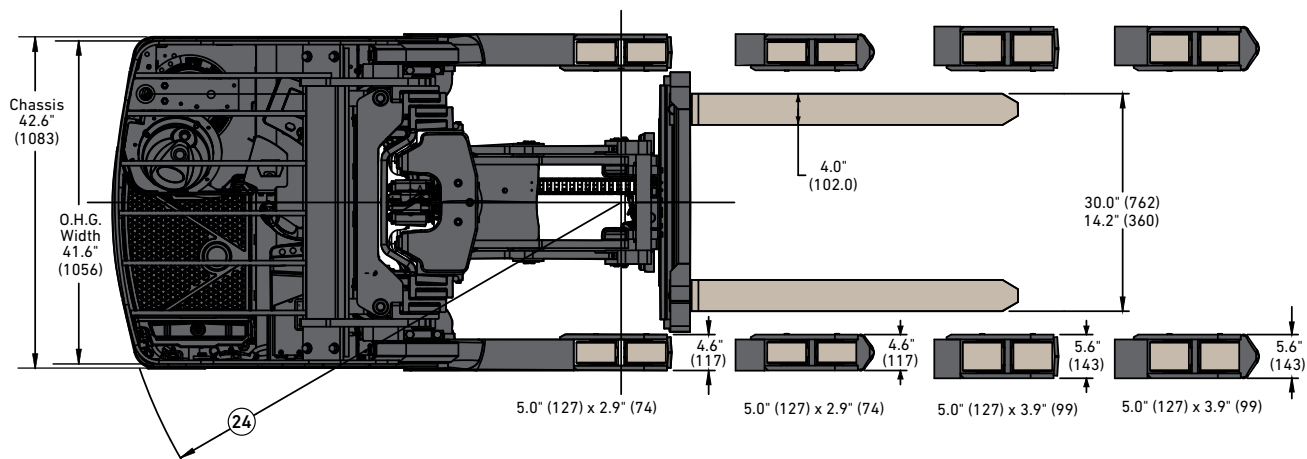

Circled truck dimensions correspond to the line numbers in the General Specifications chart. Dimensions are listed in inches (millimeters).

GENERAL SPECIFICATIONS - NR035-040DC

				Yale					
GENERAL	1	Manufacturer name							
	2	Model		NR035DC		NR040DC			
	3	Wheel base designation *		SWB		SWB			
	4	Rated capacity	lb. (kg)	3500 (1588)		4000 (1814)			
	5	Load center	Distance	in. (mm)		24 (610)			
	6	Power type	Electric, diesel, LPG		Electric - 24V	Electric - 36V	Electric - 24V	Electric - 36V	
WT.	7	Operator type		Stand		Stand			
	8	Tire type	Load/caster/drive		Poly/Poly/Poly		Poly/Poly/Poly		
	9	Wheels	Number load/drive (x=driven)		4 / 2 (1x)		4 / 2 (1x)		
	10	Truck weight	Without battery (approximate)	lb.	5340		5360		
DIMENSIONS	12	Axle loading with assembly retracted ** (front/rear)		lb.	6773/4160		7373/4082		
	13	Height	Standard lift (TOF)	in. (mm)	See mast table				
	14		Standard mast lowered (OALH)	in. (mm)					
	15		Freelift (TOF)	in. (mm)					
	16		Standard mast extended w/LBR	in. (mm)					
	17		Top of OHG	in. (mm)					
	18		Operator clearance	in. (mm)					
	19	Mast tilt angle	Forward/back	degrees	3 / 4		3 / 4		
	20	Forks	Standard (length x width x thickness)		in.	1.60 x 3.9 x 42		1.80 x 3.9 x 42	
	21	Headlength to face of forks - all battery compartments ***		in. (mm)	See mast table		See mast table		
	22	Outrigger ID		in.	34" - 49" (1" increments)		34" - 49" (1" increments)		
	23	Battery compartment size	12.5" battery compartment - (LxWxH)	in.	39.0 x 12.5 x 31.5		39.0 x 12.5 x 31.5		
			14.25" battery compartment - (LxWxH)	in.	39.0 x 14.25 x 31.5		39.0 x 14.25 x 31.5		
			16.25" battery compartment - (LxWxH)	in.	39.0 x 16.25 x 31.5		39.0 x 16.25 x 31.5		
24	Turning radius - minimum outside	12.5" battery compartment	in.	65.67		65.67			
		14.25" battery compartment	in.	65.67		65.67			
		16.25" battery compartment	in.	67.60		67.60			
25	Aisle width - zero clearance	Right angle stack	see chart	See "RAS" table		See "RAS" table			
26	Stability	Comply with ANSI		YES		YES			
TRAVEL SPEED									
28	Rearward (chassis first) - empty/RL		mph	6.5/6.5		6.5/6.5			
29	Forward (forks first) - empty/RL		mph	6.5/6.0 †		6.5/6.0 †			
LIFT SPEED									
31	Empty		ft/min	66	77	66	77		
32	2,000 lb.		ft/min	50	65	50	63		
33	3,000 lb.		ft/min	40	60	43	57		
34	3,500 lb.		ft/min	37	56	40	53		
35	4,000 lb.		ft/min	N/A		35	50		
36	4,500 lb.		ft/min	N/A		N/A			
37	Lowering speeds	Empty		ft/min	85		85		
38		RL		ft/min	85		85		
39	Size - front load wheels, standard			5 x 3.9		5 x 3.9			
41	Size, standard - drive tire/dual casters			13.5 x 5.5 / 7.9 x 2.2		13.5 x 5.5 / 7.9 x 2.2			
42	Wheelbase	12.5" battery compartment	in.	55.6		55.6			
		14.25" battery compartment	in.	55.6		55.6			
		16.25" battery compartment	in.	57.6		57.6			
43	Brakes, service/parking (method of control)			Foot / auto		Foot / auto			
44	Brake, service/parking (method of operation)			Regen / spring apply (electric release)		Regen / spring apply (electric release)			
45	Battery type			Lead acid		Lead acid			
46	Traction motor rating (60 minute rating)		hp (kw)	8 (6)	8.9 (6.6)	8 (6)	8.9 (6.6)		
47	Hoist motor rating (5 minute rating)		hp (kw)	11.1 (8.3)	17.7 (13.2)	11.1 (8.3)	17.7 (13.2)		
48	Traction motor control method			Transistor		Transistor			
49	Hoist motor control method			Transistor		Transistor			
50	Number of speeds			Infinitely variable		Infinitely variable			

SWB = Short wheel base; LWB = Long wheel base
RL = Rated load

- * Short or long wheelbase is for double reach only. LWB for double reach masts 278" and below
- ** Static with rated load and max. wt. battery
- *** Includes integral sideshift, subtract 1" for without sideshift
- † Travel speed is reduced to 6.0mph for loads 2500lbs and greater in the forks leading direction.

NOTE: Performance specifications / ratings are for truck equipped as described under Standard Features.

TRUCK DIMENSIONS - NDR030DC

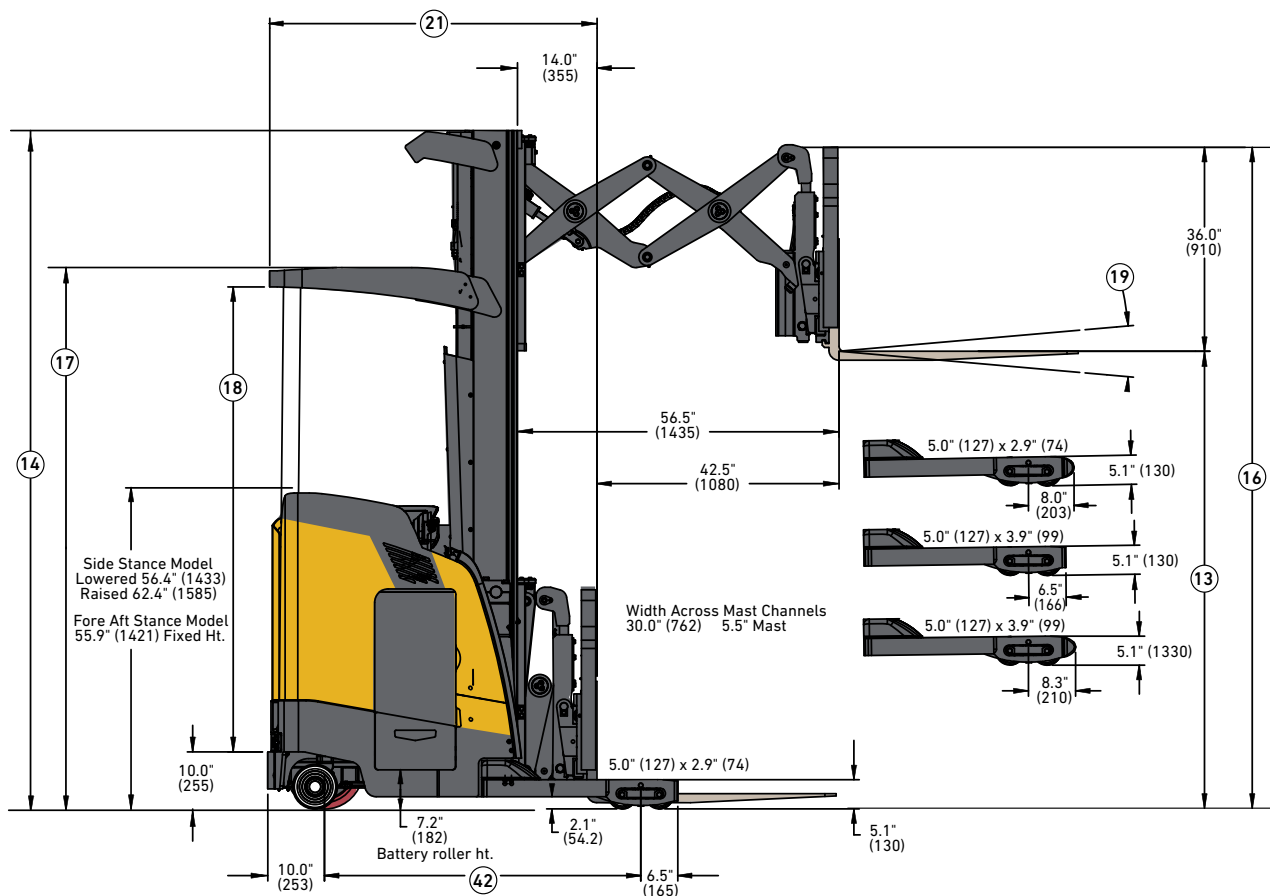
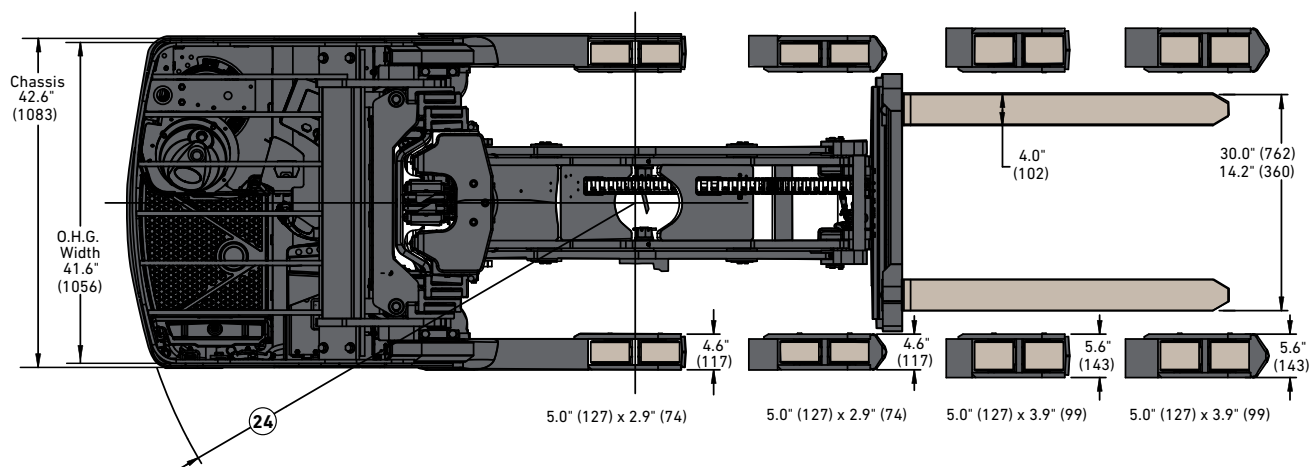

Circled truck dimensions correspond to the line numbers in the General Specifications chart. Dimensions are listed in inches (millimeters).

GENERAL SPECIFICATIONS - NDR030DC

GENERAL	1	Manufacturer name		Yale		
	2	Model		NDR030DC		
	3	Wheel base designation *		LWB		
	4	Rated capacity	lb. (kg)	3000 (1361)		
	5	Load center	Distance	in. (mm)		
	6	Power type	Electric, diesel, LPG	Electric - 24V	Electric - 36V	
WT.	7	Operator type		Stand		
	8	Tire type	Load/caster/drive	Poly/Poly/Poly		
	9	Wheels	Number load/drive (x=driven)	4 / 2 (1x)		
	10	Truck weight	Without battery (approximate)	lb.	5590	
DIMENSIONS	12	Axle loading with assembly retracted ** (front/rear)		lb.	6353/4330	
	13	Height	Standard lift (TOF)	in. (mm)	See mast table	
	14		Standard mast lowered (OALH)	in. (mm)		
	15		Freelift (TOF)	in. (mm)		
	16		Standard mast extended w/LBR	in. (mm)		
	17		Top of OHG	in. (mm)		
	18		Operator clearance	in. (mm)		
	19	Mast tilt angle	Forward/back	degrees	3 / 4	
	20	Forks	Standard (length x width x thickness)	in.	1.60 x 3.9 x 42	
	21	Headlength to face of forks - all battery compartments ***		in. (mm)	See mast table	
	22	Outrigger ID		in.	34" - 49" (1" increments)	
	23	Battery compartment size,	12.5" battery compartment - (LxWxH)	in.	N/A	
			14.25" battery compartment - (LxWxH)	in.	39.0 x 14.25 x 31.5	
			16.25" battery compartment - (LxWxH)	in.	39.0 x 16.25 x 31.5	
24		Turning radius - minimum outside	12.5" battery compartment	in.	N/A	
			14.25" battery compartment	in.	70.47	
			16.25" battery compartment	in.	72.40	
25	Aisle width - zero clearance	Right angle stack	see chart	See "RAS" table		
26	Stability	Comply with ANSI		YES		
PERFORMANCE	TRAVEL SPEED					
	28	Rearward (chassis first) - empty/RL		mph	6.5/6.5	
	29	Forward (forks first) - empty/RL		mph	6.5/6.0 †	
	LIFT SPEED					
	31	Empty		ft/min	66	77
	32	2,000 lb.		ft/min	52	65
	33	3,000 lb.		ft/min	45	57
	34	3,500 lb.		ft/min	N/A	
	35	4,000 lb.		ft/min	N/A	
	36	4,500 lb.		ft/min	N/A	
37	Lowering speeds	Empty		ft/min	85	
		RL		ft/min	85	
39	Size - front load wheels, standard			5 x 2.9		
41	Size, standard - drive tire/dual casters			13.5 x 5.5 / 7.9 x 2.2		
42	Wheelbase	12.5" battery compartment	in.	N/A		
		14.25" battery compartment	in.	60.6		
		16.25" battery compartment	in.	62.6		
43	Brakes, service/parking (method of control)			Foot / auto		
44	Brake, service/parking (method of operation)			Regen / spring apply (electric release)		
ELECTRIC	45	Battery type		Lead acid		
	46	Traction motor rating (60 minute rating)		hp (kw)	8 (6)	8.9 (6.6)
	47	Hoist motor rating (5 minute rating)		hp (kw)	11.1 (8.3)	17.7 (13.2)
	48	Traction motor control method		Transistor		
	49	Hoist motor control method		Transistor		
	50	Number of speeds		Infinitely variable		

SWB = Short wheel base; LWB = Long wheel base
RL = Rated load

* Short or long wheelbase is for double reach only. LWB for double reach masts 278" and below

** Static with rated load and max. wt. battery

*** Includes integral sideshift, subtract 1" for without sideshift

† Travel speed is reduced to 6.0mph for loads 2500lbs and greater in the forks leading direction.

NOTE: Performance specifications / ratings are for truck equipped as described under Standard Features.

NR/NDR030-040DC MAST DIMENSIONS (5.5" STANDARD)

Overall lowered ht.	Max. fork height (TOF)	Free-lift (TOF)	Overall height (mast extended) highest point w/36" LBR	Overhead guard height to top	Operator clearance	Head length (length to face of forks)			
						12.5" & 14.25"	14.25"	16.25"	
in. (mm)	in. (mm)	in. (mm)	in. (mm)	in. (mm)	in. (mm)	Single reach	Double reach	Single reach	Double reach
3-STAGE FULL FREE-LIFT (FFL) HI-VISTM MAST									
87 (2210)	191 (4851)	48 (1219)	230 (5842)	87 (2212)	74.3 (1887)	52.16	57.83	54.21	59.88
91 (2311)	203 (5156)	52 (1321)	242 (6147)	91 (2314)	78.3 (1989)	52.16	57.83	54.21	59.88
95 (2413)	212 (5385)	56 (1422)	251 (6375)	95 (2416)	82.3 (2090)	52.16	57.83	54.21	59.88
101 (2565)	227 (5766)	62 (1575)	266 (6756)	95 (2416)	82.3 (2090)	52.16	57.83	54.21	59.88
107 (2718)	242 (6147)	68 (1727)	281 (7137)	95 (2416)	82.3 (2090)	52.16	57.83	54.21	59.88
110 (2794)	251 (6375)	71 (1803)	290 (7366)	95 (2416)	82.3 (2090)	52.16	57.83	54.21	59.88
119 (3023)	272 (6909)	80 (2032)	311 (7899)	95 (2416)	82.3 (2090)	52.16	57.83	54.21	59.88

BATTERY AND COMPARTMENT SPECIFICATIONS

Battery specifications

Battery compartment size	Battery voltage	Maximum 6 hr rate		Battery compartment dimensions						Battery dimensions						Minimum batt. wt. lb. (kg)	Maximum batt. wt. lb. (kg)
				"X" max.		"Y" max.		"Z" max.		"X" max.		"Y" max.		"Z" max.			
		AH	KWH	in.	(mm)	in.	(mm)	in.	(mm)	in.	(mm)	in.	(mm)	in.	(mm)	in.	(mm)
12.50"	24	1085	25.4	39.0	990	12.5	318	31.5	800	38.8	985	12.25	311	31	788	1400 (635)	1900 (862)
14.25"	24	1240	29	39.0	990	14.25	362	31.5	800	38.8	985	14	356	31	788	1600 (726)	2100 (953)
14.25"	36	775	27.2	39.0	990	14.25	362	31.5	800	38.8	985	14	356	31	788	1600 (726)	2100 (953)
16.25"	24	1395	32.6	39.0	990	16.25	413	31.5	800	38.8	985	16	406	31	788	1850 (839)	2350 (1066)
16.25"	36	930	32.6	39.0	990	16.25	413	31.5	800	38.8	985	16	406	31	788	1850 (839)	2350 (1066)

Battery connector: 24V - Red; 36V - Gray; Position "B", lead length 16"
 Manufacturers standard cable size not to exceed 4/0 AWG
 Battery compartment is designed to accommodate standard wet cell batteries with fixed lifting eyes and no cover.
 Contact Applications Engineering to verify compatibility/fit when using maintenance free, covered or non-standard batteries.

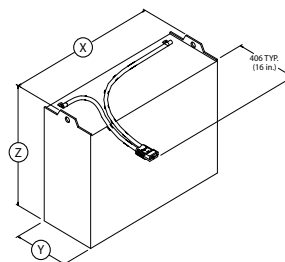

Right angle aisle stacking

NR035-040DC

12.5" or 14.25" Battery Compartment and 42" ID

3 Stage - 4" Between Loads

Pallet Length (inches)	Pallet Width (inches)			
	36	40	44	48
36	85	85	85	85
40	87	87	86	86
44	92	91	91	90
48	96	96	95	95

Subtract 1" if without sideshift
 Add 2" for 16.25" battery compartment

NDR030DC

14.25" Battery Compartment and 42" ID

3 Stage - 6" Between Loads

Pallet Length (inches)	Pallet Width (inches)			
	36	40	44	48
36	87	86	86	86
40	91	90	90	89
44	96	95	95	94
48	100	100	99	99

Sideshift is standard on double reach
 Add 2" for 16.25" battery compartment

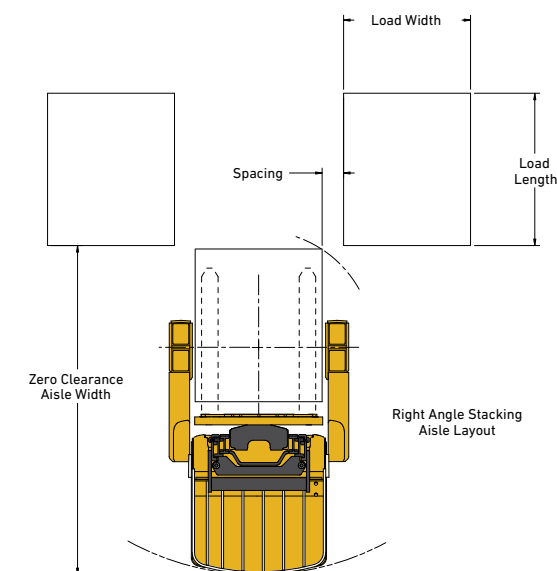

NOTE: These are "Zero Clearance" aisles and require an additional 6" to 12" to be added to provide for easier maneuvering.

FEATURES LIST - NR/NDR030-040DC

PERFORMANCE	STD	OPT	OPERATION	STD	OPT
24-volt battery (includes 350 amp red battery connector)	●		Standard construction	●	
AC traction, lift/lower and steering	●		UL classification E	●	
Transistor controller with regenerative braking	●		Sidestance operator controls	●	
Electric power steering	●		Key switch start	●	
4 Independent fully programmable performance modes - Programmable traction speed, accelerations, Lift and Lower Speeds	●		Wire mesh mast guard	●	
36-Volt battery (includes 350 amp gray battery connector)		●	Automotive steering	●	
DRIVE	STD	OPT	2 USB ports	●	
5" x 3.9" poly articulating tandem load wheels - high load compound (standard on NR035DC and NR040DC)	●		Static strap	●	
5" x 2.9" poly articulating tandem load wheels - high load compound (standard on NDR030DC)	●		Electronic horn	●	
Dual articulating polyurethane caster wheels	●		Sealed battery rollers	●	
Poly drive tire – 13.5" x 5.5"	●		Operator's overhead guard	●	
Steered caster (SPED)		●	Rear post operator protection	●	
Various sizes of load wheels with sealed bearings		●	Power disconnect button	●	
Various drive tire compounds		●	Forward stance with aft operator control handle		●
Tapered load wheel boxes		●	Reverse steering		●
LIFT	STD	OPT	Clear mast guard		●
91" / 203" / 52" – (5.5") 3-stage full free lift mast	●		Keyless start		●
Tilting carriage (3° fwd, 4° back)	●		Rotary joystick (standard for cooler/freezer)		●
Single reach mast (24" extend) with 33.5" wide Class II with integral sideshift (hook type carriage) - Standard Single Reach	●		Battery gate interlock		●
Double reach mast (42" extend) with 33.5" wide Class II with integral sideshift (hook type carriage) - Standard Double Deep Reach	●		Cooler/freezer construction (0°F to 120°F) with rubber floor mat		●
36" high load backrest extension	●		Outrigger ID - 34" to 49" in 1" Increments		●
Lift limit		●	Audible back-up and motion alarms		●
48" high load backrest extension		●	Visible amber strobe light - continuous activated		●
Single reach mast without integral sideshift for standard 33.5" wide carriage		●	Impact monitor		●
Various mast heights		●	Blue LED spotlights		●
HANDLING	STD	OPT	RF terminal bracket		●
Forks: 1.8" x 3.9" (45 mm x 100 mm) 42" (1067 mm) class II, hook type (standard on NR040DC)	●		RF handheld scanner holder		●
Forks: 1.6" x 3.9" (40 mm x 100 mm) 42" (1067 mm) class II, hook type (standard on NDR030DC and NR035DC)	●		12-volt DC auxiliary power supply		●
Fully proportional lift/lower control	●		Wire mesh on top overhead guard		●
Control handle with simultaneous hydraulic functions	●		Rear operator compartment door (SPED)		●
Load weight display		●	Yale Vision		●
Fork height display		●	ENERGY SYSTEM	STD	OPT
Reduced travel speed with carriage extended		●	Lead acid	●	
Various fork lengths		●	SUPPLEMENTAL	STD	OPT
ERGONOMICS	STD	OPT	Operating manual	●	
Operator sensing system	●				
EZ Ride floor	●				
Low profile anti-fatigue floor mat	●				
Adjustable armrest and backrest (sidestance operator controls only)	●				
Steer tiller position adjustment	●				
Low step height	●				
Padded operator compartment	●				
5" smart display: color touchscreen	●				
Yale Smart Ride® floor (full suspension floor)		●			
7" smart display: color touchscreen		●			
Operator overhead fan		●			
Dual LED headlights		●			
Rear LED worklight		●			
Operator LED desktop light		●			

* Doors are intended to protect the operator from objects that may enter the operator's compartment but they may also slow the operator's egress in emergency situations. A review of the forklift's intended environment should be conducted before selecting a door as optional equipment.

** Sideshift includes 7" travel (3.5" each side). Sideshift travel will be reduced to 3" total (1.5" each side) when Outrigger ID is less than 39".

About Yale



Yale Lift Truck Technologies leverages over a century of material handling experience and substantial investment in innovation to bring the most advanced technology-driven lift truck solutions to market. The company offers a full line of award-winning lift trucks, including reach trucks, order pickers, turret trucks, pallet jacks and trucks, pallet stackers, tow tractors and counterbalanced forklifts, as well as powerful operator assist solutions, proven robotics and a wide range of power sources to help customers adapt to today's demanding supply chain. Yale and its independent dealer network support these solutions with comprehensive after-sales service, parts, financing and training.

Yale Lift Truck Technologies is a trading name of Hyster-Yale Asia-Pacific Pty Ltd., a wholly owned subsidiary of Hyster-Yale Materials Handling, Inc.(NYSE:HY) which is headquartered in Cleveland, Ohio and operates globally.

MATERIALS HANDLING FOR:

Third-party logistics (3PL)

Auto parts distribution

Beverage

Cold & frozen foods

Food distribution

Food processing

Furniture & furnishings

Government

Health & pharma

Home centers & durables

Retail & e-commerce

Yale Lift Truck Technologies | Pacific
1/23 Rowood Road
Prospect NSW 2148

Yale Lift Truck Technologies | Asia
16 Tuas Avenue 20
Singapore 638827

yale.com

© 2023 Hyster-Yale Group, Inc., all rights reserved. YALE and  are trademarks of Hyster-Yale Group, Inc. Trucks may be shown with optional equipment and/or features not available in all regions. Specifications and details in this brochure are subject to change without prior notification.