



# UX Series

**GDP40-50UX / 4,000-5,000kg**

Internal Combustion Counterbalanced Forklift

# GDP40-50UX features.

The Yale GDP40-50UX was designed for operations looking for a reliable, cost-effective solution to get the job done—all backed by the trusted Yale name.

## Model range

The GDP40-50UX consists of 4,000-5,000kg trucks, available in three different capacities:

**4,000kg – GDP40UX**

**4,500kg – GDP45UX**

**5,000kg – GDP50UX**

## DESIGN

The design of the UX series has been engineered with the operator in mind. The ergonomically designed compartment provides a natural and comfortable environment to help reduce fatigue throughout the shift. A range of standard features and options help to configure the truck to the needs of the application.

## LOW COST OF OWNERSHIP

The use of high quality and robust components contribute to reliable operations and lower wear and tear. This, together with fast availability of cost-effective replacement parts helps to reduce maintenance requirements and costs.

## EASY TO OPERATE

The ergonomically designed operator's compartment, with familiar automotive layout, means that drivers will be able to work comfortably. A range of standard features and options help the truck to be configured to the needs of the application.

## SERVICEABILITY

Due to the simplicity of the components and specifications, servicing can be carried out quickly and easily.





**1 WIDE VIEW MAST**

The wide view mast provides the operator with a significant front field of view, minimizing blind spots and increasing operator comfort, thereby enabling safe, productive and efficient operation.

**2 SMALL STEERING WHEEL**

The adjustable steering wheel position provides convenience for the operator as it provides 8 degrees of adjustment. Low steering effort makes it easy to operate in confined spaces.

**3 FULL SUSPENSION SEAT**

Full suspension seat that offers excellent comfort, fitted with an operator's presence system as standard.

**4 HIGH STRENGTH OVERHEAD GUARD**

The overhead guard features profiled steel, with high strength materials to help enhance reliability and operator protection.

**5 INDUSTRIAL ENGINE**

The UX Mitsubishi industrial engine provides good reliability and ease of use for sourcing of replacement parts.

**6 LOW STEP HEIGHT**

The conveniently positioned low step provides easy access to the truck.

# Engineered for **drivers.**



## YALE DISPLAY WITH 3.5" LCD

- The Yale UX Series Forklift adopts a 3.5" LCD display, providing convenient viewing of the display data when driving and operating



## SUSPENSION SEAT

- Full suspension seat offers excellent comfort
- Operator presence system as standard



## SPACIOUS FOOTWELL

- Spacious foot room design provides comfort, convenience
- Control pedals provide extra foot space which reduces operator fatigue and increases operator comfort



## EXCHANGEABLE COMPONENTS

- The engine cover, instrument panel, display and most other components are exchangeable with other capacities in the same range. Front fenders are adaptable to single or dual wheel configuration

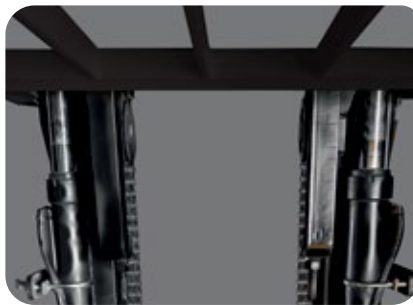

## HIGH-STRENGTH OVERHEAD GUARD

- Profiled steel overhead guard
- High strength roof enhances reliability and operator protection



## SMALL DIAMETER STEERING WHEEL WITH ADJUSTABLE STEER COLUMN

- The 300mm diameter steering wheel is responsive and provides 8 degrees of tilt adjustment to suit a variety of different operators



## GOOD THROUGH-MAST VISIBILITY

- The wide view mast delivers excellent visibility of the load and operator's forward field of view. The mast is designed with a composite roller structure



## LARGE ACCESS AREA FOR SERVICE AND REPAIRS

- Large access space to engine compartment makes service and repairs easy

## ENGINE SPECIFICATIONS

### Mitsubishi 5.0L, Diesel

6 Cylinder	Overhead valve
Displacement	4.996 litre
Torque	250Nm @ 1,600rpm
Power	52kW @ 2,300rpm
Air filtration	Two stage, dry type
IDI fuel injection system	



## MAST DIMENSIONS GDP40-45UX

Mast Specification	Maximum Fork Height	Overall Lowered Height	Overall Extended Height		Free-Lift (TOF)		Load Distance	Tilt	Capacity 500mm Load Center From Single Tire		Mast Weight
			w/Load Backrest	w/o Load Backrest	w/Load Backrest	w/o Load Backrest			GDP40UX	GDP45UX	
			mm	mm	mm	mm					
<b>2-Stage Limited Free-Lift (LFL) Mast</b>											
M300	3000	2250	4260	3850	150	150	575	12°/6°	4000	4500	1310
M330	3300	2400	4560	4150	150	150	575	12°/6°	4000	4500	1335
M350	3500	2500	4760	4350	150	150	575	12°/6°	4000	4500	1360
M370	3700	2600	5010	4600	150	150	575	12°/6°	4000	4500	1370
M400	4000	2800	5260	4850	150	150	575	12°/6°	3800	4250	1420
M450	4500	3050	5760	5350	150	150	575	6°/6°	3400	3800	1490
M500	5000	3300	6260	5850	150	150	575	6°/6°	2800	3150	1540
M550	5500	3600	6760	6350	150	150	575	6°/3°	2250	2800	1630
M600	6000	3850	7260	6850	150	150	575	6°/3°	1950	2500	1680
<b>2-Stage Full Free-Lift (FFL) Mast</b>											
M300	3000	2250	4210	3800	1030	1425	585	12°/6°	4000	4500	1420
M330	3300	2400	4510	4100	1180	1575	585	12°/6°	3960	4460	1430
M350	3500	2500	4710	4300	1280	1675	585	12°/6°	3920	4420	1470
M375	3750	2625	4960	4550	1405	1800	585	12°/6°	3850	4350	1500
M400	4000	2800	5210	4800	1580	1975	585	12°/6°	3750	4250	1540
<b>3-Stage Full Free-Lift (FFL) Mast</b>											
TFM400	4000	2110	5260	4860	885	1270	630	6°/6°	3600	4000	1760
TFM435	4350	2235	5610	5210	1010	1395	630	6°/6°	3400	3800	1800
TFM450	4500	2285	5760	5360	1060	1445	630	6°/6°	3200	3600	1820
TFM480	4800	2385	6060	5660	1160	1545	630	6°/6°	3000	3350	1860
TFM500	5000	2485	6260	5860	1260	1645	630	6°/6°	2800	3150	1900
TFM540	5400	2610	6660	6260	1380	1770	630	6°/3°	2250	2550	1940
TFM600	6000	2850	7260	6860	1625	2010	630	6°/3°	1700	1950	2090
TFM650	6500	3050	7760	7360	1825	2210	630	6°/3°	1200	1500	2240

## MAST DIMENSIONS GDP50UX

Mast Specification	Maximum Fork Height	Overall Lowered Height	Overall Extended Height		Free-Lift (TOF)		Load Distance	Tilt	Capacity 500mm Load Center From Single Tire	Mast Weight
			w/Load Backrest	w/o Load Backrest	w/Load Backrest	w/o Load Backrest			GDP50UX	
			mm	mm	mm	mm			mm	
<b>2-Stage Limited Free-Lift (LFL) Mast</b>										
M300	3000	2250	4260	3850	155	155	580	12°/6°	5000	1325
M330	3300	2400	4560	4150	155	155	580	12°/6°	5000	1350
M350	3500	2500	4760	4350	155	155	580	12°/6°	5000	1375
M370	3700	2600	5010	4600	155	155	580	12°/6°	5000	1385
M400	4000	2800	5260	4850	155	155	580	12°/6°	4750	1435
M450	4500	3050	5760	5350	155	155	580	6°/6°	4250	1505
M500	5000	3300	6260	5850	155	155	580	6°/6°	3500	1555
M550	5500	3600	6760	6350	155	155	580	6°/3°	2850	1645
M600	6000	3850	7260	6850	155	155	580	6°/3°	2550	1695
<b>2-Stage Full Free-Lift (FFL) Mast</b>										
M300	3000	2250	4210	3800	1425	1425	590	12°/6°	5000	1435
M330	3300	2400	4510	4100	1575	1575	590	12°/6°	4960	1465
M350	3500	2500	4710	4300	1675	1675	590	12°/6°	4920	1485
M375	3750	2625	4960	4550	1800	1800	590	12°/6°	4850	1515
M400	4000	2800	5210	4800	1975	1975	590	12°/6°	4750	1555
<b>3-Stage Full Free-Lift (FFL) Mast</b>										
TFM400	4000	2110	5260	4860	1270	1270	635	6°/6°	1760	1775
TFM435	4350	2235	5610	5210	1395	1395	635	6°/6°	1800	1815
TFM450	4500	2285	5760	5360	1445	1445	635	6°/6°	1820	1835
TFM480	4800	2385	6060	5660	1545	1545	635	6°/6°	1860	1875
TFM500	5000	2485	6260	5860	1645	1645	635	6°/6°	1900	1915
TFM540	5400	2610	6660	6260	1770	1770	635	6°/3°	1940	1955
TFM600	6000	2850	7260	6860	2010	2010	635	6°/3°	2090	2105
TFM650	6500	3050	7760	7360	2210	2210	635	6°/3°	2240	2255

Capacities are with standard carriage.

# TRUCK DIMENSIONS GDP40-50UX

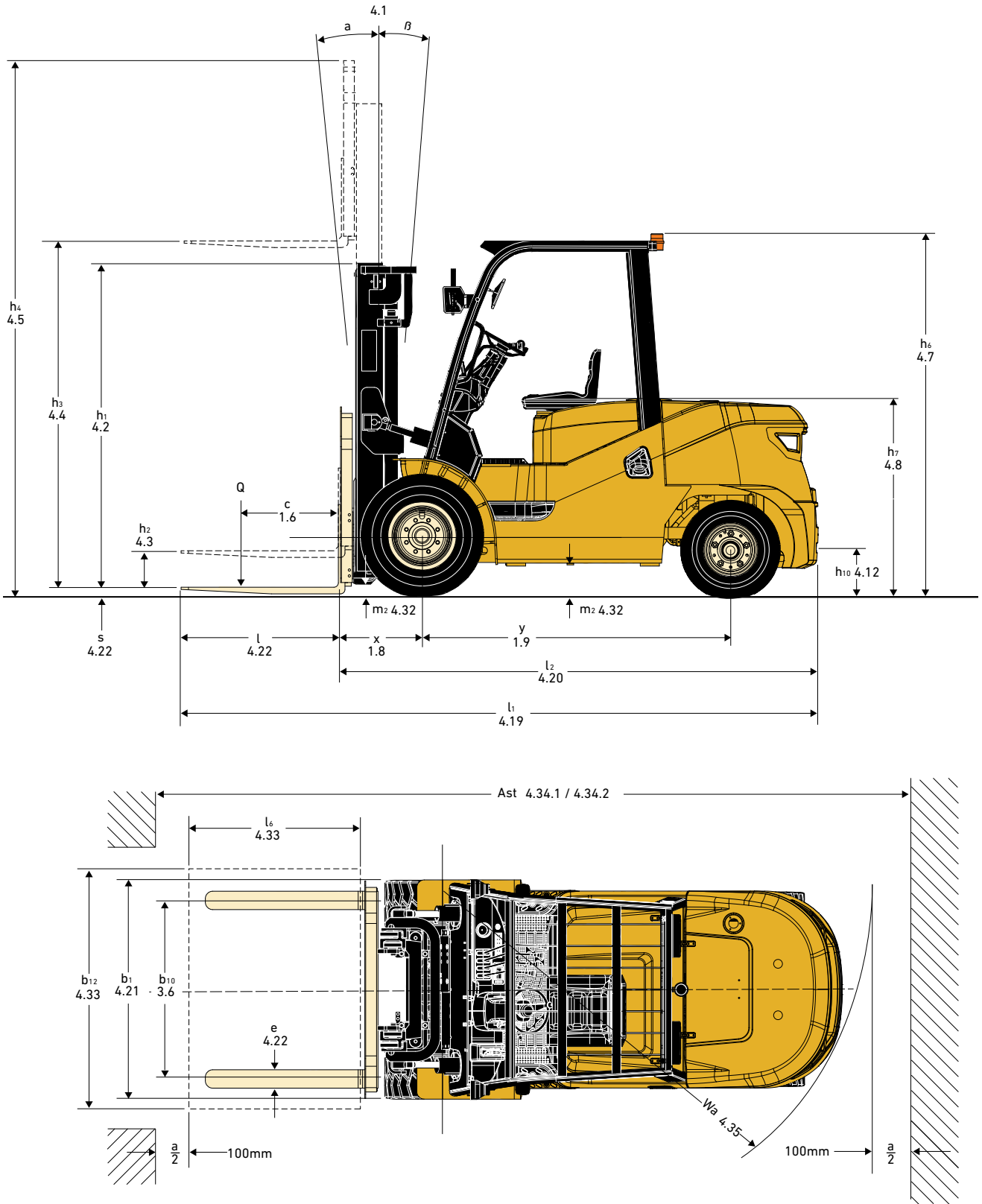

## GENERAL SPECIFICATIONS GDP40-50UX

DISTINGUISHING MARK	1.1	Manufacturer		Yale	Yale	Yale
	1.2	Model designation		GDP40UX	GDP45UX	GDP50UX
	1.3	Power: battery, diesel, LPG, electric mains		Diesel	Diesel	Diesel
	1.4	Operation: manual, pedestrian, stand, seat, orderpicker	Q (kg)	Seat	Seat	Seat
	1.5	Load capacity	c (mm)	4000	4500	5000
	1.6	Load center	x (mm)	500	500	500
	1.8	Load distance	y (mm)	575	575	580
	1.9	Wheelbase	kg	2100	2100	2100
	WEIGHT	2.1	Unladen weight	kg	6230	6500
2.2		Axle loading, laden front / rear	kg	9014 / 1216	9766 / 1234	10900 / 1200
2.3		Axle loading without load, front		2978 / 3252	2837 / 3663	3160 / 3850
TIRES, CHASSIS	3.1	Tires: P = pneumatic, V = cushion, SE = superelastic		P	P	P
	3.2	Tire size, front		300-15-21PR	300-15-18PR	300-15-18PR
	3.3	Tire size, rear		7.00-12-15PR	7.00-12-12PR	7.00-12-12PR
	3.5	Number of wheels, front/rear (X = driven)	b10 (mm)	2 X 2	2 X 2	2 X 2
	3.6	Track width, front	b11 (mm)	1190	1190	1190
	3.7	Track width, rear	/ (°)	1130	1130	1130
	DIMENSIONS	4.1	Mast tilt, forward a/back β	h1 (mm)	6 / 12	6 / 12
4.2		Height of mast, lowered	h2 (mm)	2250	2250	2250
4.3		Free lift	h3 (mm)	150	150	155
4.4		Lift height	h4 (mm)	3000	3000	3000
4.5		Height of mast, extended	h6 (mm)	4260	4260	4260
4.7		Height to top of overhead guard	h7 (mm)	2250 (2400)	2250 (2400)	2250 (2400)
4.8		Seat height	h10 (mm)	1350	1350	1350
4.12		Towing coupling height	l1 (mm)	340	340	340
4.19		Overall length	l2 (mm)	4280	4280	4345
4.20		Length to face of forks	b1 (mm)	3210	3210	3275
4.21		Overall width, Standard / Dual	s/e/l (mm)	1490	1490	1490
4.22		Fork dimensions ISO2331		50 / 150 / 1070	50 / 150 / 1070	55 / 150 / 1070
4.23		Fork carriage to DIN 15173. Class, A/B	b3 (mm)	ISO 3A	ISO 3A	ISO 3A
4.24		Fork carriage width	m1 (mm)	1380	1380	1380
4.31		Ground clearance under mast, with load	m2 (mm)	155 / 130	155 / 130	155 / 130
4.32		Ground clearance at centre of wheelbase	b12 x l6 (mm)	186	186	186
4.33		Load dimension b12 x l6 crossways	Ast (mm)	1000 x 1000	1000 x 1000	1000 x 1000
4.34		Aisle width with predetermined load dimensions	Ast (mm)	4625	4625	4685
4.34.1		Aisle width with pallets 1000mm x 1200mm crossways	Ast (mm)	4625	4625	4685
4.34.2		Aisle width with pallets 800mm x 1200mm crossways	Wa (mm)	4425	4425	4485
4.35		Outer turning radius	b13 (mm)	2850	2850	2905
4.36	Inner turning radius	mm	100	100	100	
4.42	Step height (from ground to running board)	mm	885	885	885	
4.43	Step height (between intermediate steps and floor)	km/h	520	520	520	
PERFORMANCE DATA	5.1	Travel speed laden/unladen - Shift 2	km/h	24 / 25	24 / 25	25 / 27
	5.1	Travel speed laden/unladen - Shift 1	km/h	17 / 18	17 / 18	17 / 18
	5.1.1	Travel speed, laden / unladen, backwards - Shift 2	km/h	-	-	-
	5.1.1	Travel speed, laden / unladen, backwards - Shift 1	m/s	19 / 20	19 / 20	19 / 20
	5.2	Lifting speed laden/unladen	m/s	530 / 560	530 / 560	530 / 560
	5.3	Lowering speed laden/unladen	N	480 / 500	480 / 500	480 / 500
	5.6	Maximum drawbar pull laden/unladen	N	30 / 23	30 / 23	30 / 23
	5.6.1	Drawbar pull laden/unladen, @ 1.6km/h	N	25 / 22	25 / 22	25 / 22
	5.6.2	Drawbar pull laden/unladen, @ 4.8km/h	%	19 / 16.5	19 / 16.5	19 / 16.5
	5.7	Gradeability laden/unladen, @ 1.6km/h	s	24 / 25	22 / 25	20 / 25
	5.9	Acceleration time with/without load (S) 15m	s	5.05(S1) / 4.76(S2)	5.21(S1) / 4.86(S2)	5.41(S1) / 5.06(S2)
5.9	Acceleration time with/without load (S) 15m		4.15(S1) / 3.95(S2)	4.32(S1) / 4.15(S2)	4.52(S1) / 4.35(S2)	
5.10	Service brake		hydraulic	hydraulic	hydraulic	
COMBUSTION ENGINE	7.1	Engine manufacturer/type	Kw	Mitsubishi S6S	Mitsubishi S6S	Mitsubishi S6S
	7.2	Engine output, in accordance with ISO1585	min-1	52	52	52
	7.3	Governed speed	(-) / (cm³)	2300	2300	2300
	7.4	Number of cylinders/displacement	ℓ/h or kg/h	6 / 4966	6 / 4966	6 / 4966
	7.5	Fuel consumption in accordance with VDI cycle	t/h	5.9	6.1	6.4
	7.6	Turnover output	ℓ/h or kg/h	270t/h	300t/h	345t/h
	7.7	Energy consumption at turnover output		7.77kg/h	8.07kg/h	8.37kg/h
ADDITIONAL DATA	8.1	Type of drive unit	bar	E-Hydraulic	E-Hydraulic	E-Hydraulic
	10.1	Operating pressure for attachments	l/min	19.5	19.5	19.5
	10.2	Oil volume for attachments	l	70	70	70
	10.3	Hydraulic oil tank, capacity	l	108	108	108
	10.4	Fule tank, capacity	dB (A)	100	100	100
	10.7	Average noise level at operator's ear EN 12053	dB (A)	88	88	88
	10.7.1	Sound power level during the workcycle		109.6	109.6	109.6
	10.8	Towing coupling, type DIN 15170		Pin	Pin	Pin

## FEATURES LIST

### STANDARD FEATURES

MITSUBISHI 5.0L diesel S6S 52kw
F2/R1 speed transmission
2 stage limited free lift mast - 3000mm max lift height, 2265mm overall lowered height
6° forward /12° mast tilt (for 2LFL & 2FFL 3000mm-3750mm)
1380mm hook type carriage
1070 X 150 x 55mm hook type standard tapered forks
2 function hose group
2 function manual hydraulic levers
Pneumatic shaped solid (PSS) drive tires - 300-15NHS, steer tires - 7.00-12NHS
F/R lever direction control
Horizontal exhaust
Non-suspension seat
2250mm overhead guard
Park brake alarm
Operator presence system (ops)
Steering wheel with knob and adjustable tilt steering column
Standard environmental construction (-10° C to 40° C ambient)
Spanish literature package
Warranty - 12 months / 2,000 hours manufacturer's warranty

### OPTIONAL FEATURES

See mast chart (page 5) for other available mast options
6° forward /6° back mast tilt (for 2LFL & 2FFL & 3FFL 4000mm-5000mm)
3° forward /6° back mast tilt (for 2LFL & 2FFL & 3FFL 5400mm-6500mm)
Hook type carriages - 1600mm, 1700mm, 1800mm
1380mm ldsj integral sideshift carriage (hook type forks)
1380mm hang-on sideshift carriage (hook type forks) - LDSJ or cascade
1245mm cascade hang-on sideshift fork positioner carriage (hook type forks)
1428mm ldsj hang-on sideshift fork positioner carriage (hook type forks)
Hook type standard tapered forks - 1220 x 150 x 50mm, 1220 x 150 x 55mm
1370 X 150 x 50mm, 1370 x 150 x 55mm, 1520 x 150 x 50mm, 1520 x 150 x 55mm
1670 X 150 x 50mm, 1670 x 150 x 55mm, 1820 x 150 x 50mm, 1820 x 150 x 55mm

### OPTIONAL FEATURES (cont'd)

1970 X 150 x 50mm, 1970 x 150 x 55mm, 2120 x 150 x 55mm, 2120 x 150 x 60mm
2220 X 150 x 55mm, 2220 x 150 x 60mm, 2300 x 150 x 55mm, 2300 x 150 x 60mm
2440 X 150 x 55mm, 2440 x 150 x 60mm
2 function hose group - for 2 FFL OR 3 FFL mast
3 function hose group - for 2 LFL, 2FFL, OR 3 FFL mast
4 function hose group - for 2 LFL, 2 FFL, OR 3 FFL mast
3 function or 4 function w/o clamping, 4 function w/ clamping manual hydraulic levers
Pneumatic drive tires - 300-15-18PR, steer tires - 7.00-12NHS
Pneumatic duel drive tires - 300-15-18PR, steer tires - 7.00-12-12PR
Pneumatic shaped solid (PSS) duel drive tires - 300-15-NHS, steer tires - 7.00-12-12NHS
2 front LED / 1 rear LED work lights
Amber led strobe
Audible alarm
Overhead exhaust
Spark arrester
High air intake with pre-cleaner
2392mm overhead guard
Multiple cab options - PVC rain top - full cab (w/ front wiper with water spray, and rear wiper - front, top, and rear panels (w/ front wiper with water spray, and rear wiper - front and top panels (w/ front wiper with water spray) - front (w/ front wiper only)
Cab heater
Cab A/C
Rear drive handle w/ horn button
Battery disconnect
Locking fuel cap
Side mirrors
Cold environmental construction (-20°C to 40°C ambient)
English US literature package

## Yale Materials Handling Corporation

P.O. Box 7367  
Greenville, NC 27835-7367  
U.S.A.

[www.yale.com](http://www.yale.com)

YALE,  and PEOPLE. PRODUCTS. PRODUCTIVITY. are trademarks, service marks or registered marks in the United States and certain other jurisdictions. © Yale Materials Handling Corporation 2021. All Rights Reserved.

Trucks may be shown with optional equipment. Truck performance may be affected by the condition of the vehicle, how it is equipped and the application. Specifications are subject to change without notice. Consult your Yale Dealer if any of the information shown is critical to your application.

