

GC-VX

VERACITOR® CUSHION TIRE TRUCKS 8,000 lbs

Yale Veracitor® GC-VX Series

This series of trucks delivers outstanding performance for medium to heavy duty applications with state-of-the-art features and superior power. The Veracitor® truck provides excellent performance, is optimized to help provide the lowest hourly cost of operation, and is geared to minimize your cost of acquisition without compromising performance.

Kubota 3.8L LPG Engine features a cast iron cylinder head and deep skirt engine block for strength and resistance to shock. The Kubota also features a long cylinder stroke for improved torque. All Kubota engines include hardened exhaust valve seats with stellite coated valves for superior durability. The innovative Yale® Flex Performance Technology™ offers selectable performance modes that provide the flexibility to maximize fuel economy or productivity to match application needs.

Fuel System

The LPG engine uses a vaporizer/regulator to convert the fuel from a liquid to a gas for combustion. The Engine Control Unit electronically regulates the fuel, air, and spark advance to provide the necessary torque. The engine control unit's inputs include manifold air pressure, manifold air temperature, engine coolant temperature, accelerator pedal position, throttle position, engine speed, cam signal, and oxygen sensor signal. The system is designed to allow heavy petroleum deposits such as polypropylene or "tar" to pass through the system.

Transmissions

There are four powertrain configurations available that will handle a wide variety of material handling applications. Both One and Two Speed Electronic Powershift Transmissions, feature electronic inching (requires no adjustment), electric shift control, neutral start switch, and anti-restart protection. A single pedal controls both inching and braking. Optional dual inch/brake pedals are available for operators who prefer this design. A 100 mesh suction and a 10 micron return line filtration protect the transmission from abrasive contaminants.

The Techtronix 100 features Auto Deceleration through the controlled application of clutch packs, and also reduce tire spin by precisely regulating engine speed during controlled power reversals. The Techtronix 100 series is available in one or two speeds.

Cooling System employs an 18" (diameter) blade pusher-type fan. An optional on-demand cooling system automatically clears the radiator of debris by periodically reversing direction every 20 minutes, avoiding time spent manually cleaning the radiator. By maintaining optimum engine and transmission temperatures, the **on-demand cooling system** virtually eliminates the possibility of overheating and extends system component life.

The sealed cooling system operates at a pressure of 15 psi and includes a coolant recovery tank for visual inspection of coolant level. A permanently lubricated water pump and a high capacity, cross-flow radiator ensure rapid heat dissipation. Transmission oil cooler is integrated into the heavy duty, anti-clog radiator and is located in the side tank. The combi-cooler radiator (standard with all Techtronix transmissions) features an externally mounted transmission oil cooler for increased heat transfer capability. All radiators are soft-mounted for excellent durability.

Drive Axle

The drive axles are designed to withstand heavy loads and absorb shocks. The wheel hubs rotate on large tapered roller bearings. The drive shaft transmits rotational torque to the drive axle from the engine and transmission. Transmission torque is distributed through a planetary gear reduction and a spiral bevel gear set.

The drive axle is a self-contained assembly that is isolated from the transmission by heavy duty rubber isolators. The axle shafts' root splines are cut through the hobbing process for increased resistance to torsion stress and long life. A magnetic sump plug is used to collect any metal particles that are circulating in the axle oil, preventing component wear.

LP Engine Specifications

Engine	Kubota 3.8L
Cylinders	I-4
Displacement	230 cu.in./3.8 liter
Torque	221 lb.ft. @ 1000 RPM
Horsepower	74 hp @ 1800 RPM
Air Filtration	Two Stage, Dry Type
Emission Control	Closed loop

Wet Disc Brakes

All models come standard with wet disc brakes, providing excellent stopping power with an extremely long service life. The brake system is contained within the axle for protection from wet or dirty environments. The force cooled system is designed to handle continuous, high load, high cycle applications with lots of braking events and in the worst conditions. The inboard design also avoids system damage caused by material being wrapped around the axle.

The brake system oil is circulated through the brake, then cooled to maintain proper temperatures. The axle features a temperature sensing system and adjusts truck performance if brake temperatures reach higher levels. The brake system is hydraulically boosted to minimize pedal effort. The independent, hand-adjustable parking brake with push-button release has an audible alarm to indicate when the operator has left the truck without applying the parking brake.

(continued on back)



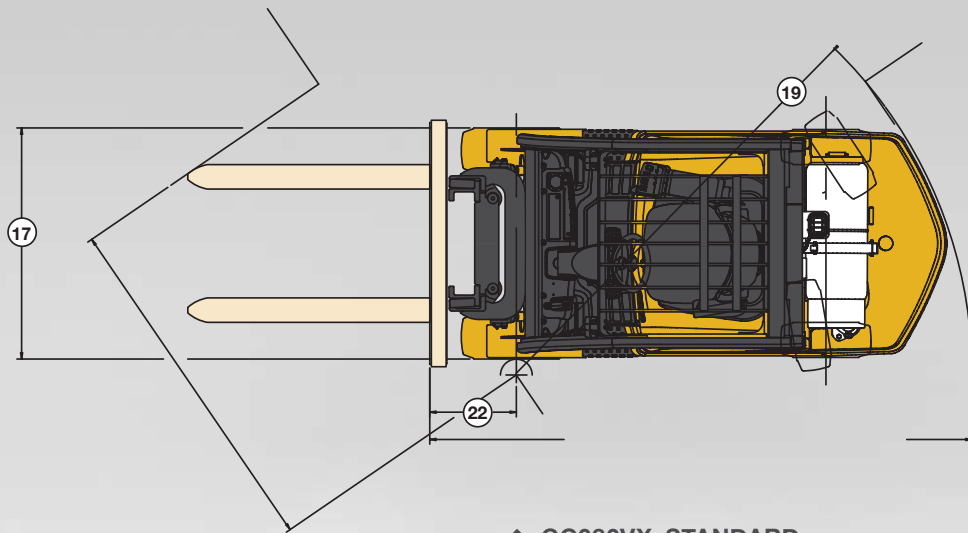

▲ GC080VX STANDARD

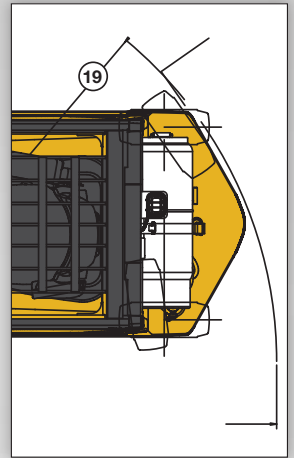

GC080VXBCS ▲
(Box Car Special)

	Non-Susp	Semi	Full	Swivel Full
Tall OHG (Std.)	42.0 (1068)	42.5 (1080)	41.0 (1041)	41.0 (1041)
Short OHG (Opt.)	39.4 (1001)	39.9 (1013)	2.64 (1001)	2.64 (1001)

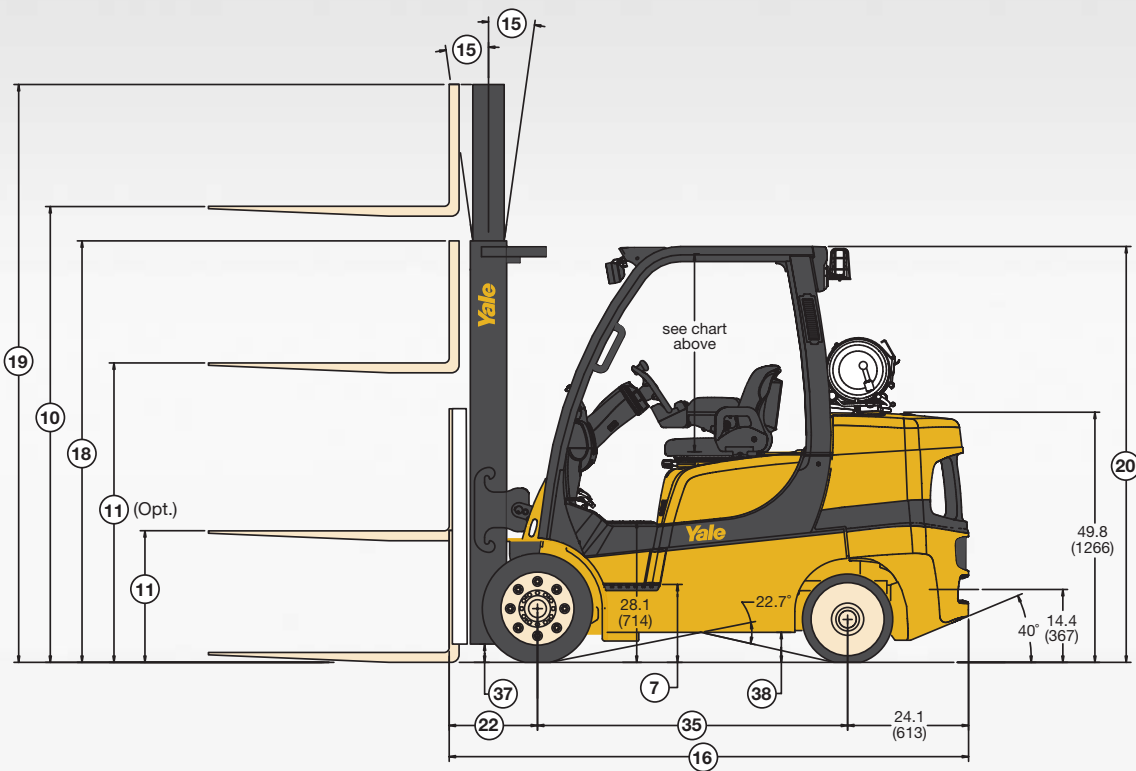

▲ GC080VX STANDARD

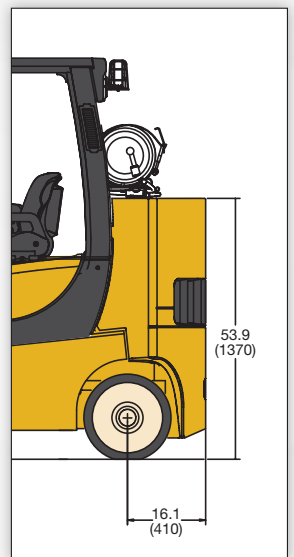

GC080VXBCS ▲
(Box Car Special)

Circled dimensions correspond to the line numbers on the tabulated chart inside the spec sheet. Dimensions are in inches (millimeters).

GENERAL	1	Manufacturer Name		Yale	
	2	Model		GC080VX	
		Engine		Kubota 3.8L LPG	
	3	Rated Capacity	lb (kg)	8000 (3629)	
	4	Load Center, Distance	in (mm)	24 (610)	
	5	Power Type		LPG	
	6	Operator Type		Sit-Down Rider	
	7	Step Height	in (mm)	15.6 (396)	
	8	Tire Type - Cushion, Solid, Pneumatic		Cushion	
DIMENSIONS	9	Wheels, Number - Front/ Rear	X driven	2x/2	
	10	Lift Height, Top of Fork (TOF)	in (mm)	120 (3050)	
	11	Lift Heights, Standard Limited Free Lift (LFL) with LBR	in (mm)	6 (150)	
		Lift Heights, Optional Full Free Lift (FFL) with LBR (TOF)	in (mm)	35 (900)	
	12	Standard Carriage Width	in (mm)	42 (1067)	
	13	Forks, Thickness x Width x Length	in (mm)	2 X 5 X 48 (50 X 125 X 1219)	
	14	Fork Spread, Outside Dimensions	in (mm)	38.3 (972)	
	15	Mast Tilt Angles, Forward/Backward	degrees	5F/6B	
	16	Length To Face of Forks	in (mm)	103.5 (2630)	
	17	Overall Width, Standard Tread	in (mm)	46.1 (1170)	
		Overall Width, Wide Tread	in (mm)	50.0 (1270)	
	18	Height, Standard Mast - Lowered	in (mm)	84 (2134)	
	19	Height, Standard Mast - Extended with LBR	in (mm)	169 (4284)	
		Height, Standard Mast - Extended without LBR	in (mm)	149 (3783)	
	20	Height, Standard Overhead Guard	in (mm)	86 (2171)	
		Height, Optional Overhead Guard	in (mm)	83 (2104)	
	21	Turning Radius, Minimum Outside (OTR)	in (mm)	90.5 (2298)	
	22	Length, Center of Wheel to Face of Forks	in (mm)	17.6 (447)	
	23	Aisle Width, Right Angle Stack (Add Length of Load)	in (mm)	108.1 (2746)	
	24	Equal Aisle, 90-Degree Intersecting Aisle (48" L X 40" W)	in (mm)	81.7 (2075)	
	PERFORMANCE †	25	Travel Speed RL/NL 1-Speed	mph (km/h)	10.7/10.7 (17.2/17.2)
			2-Speed	mph (km/h)	13.7/13.9 (22/22.4)
		26	Lift Speed, Standard 2-Stage LFL RL/NL	ft/min (m/s)	120/122 (.61 /.62)
			Lift Speed, Optional 2-Stage FFL RL/NL	ft/min (m/s)	106/108 (.54/.55)
		Lift Speed, Optional 3-Stage FFL RL/NL	ft/min (m/s)	112/114 (.57/.58)	
27		Lowering Speed, Standard 2-Stage LFL RL/NL	ft/min (m/s)	93/108 (.47/.55)	
		Lowering Speed, Optional 2-Stage FFL RL/NL	ft/min (m/s)	71/98 (.36/.50)	
		Lowering Speed, Optional 3-Stage FFL RL/NL	ft/min (m/s)	87/104 (.44/.53)	
28		Max Drawbar Pull RL/NL 1-Speed	lb (kg)	7132/2878 (3235/1306)	
		2-Speed	lb (kg)	8563/2878 (3884/1306)	
		Drawbar Pull @ 1 mph RL/NL 1-Speed	lb (kg)	6173/2878 (2800/1306)	
		2-Speed	lb (kg)	7162/2878 (3249/1306)	
29		Max Gradeability RL/NL †† 1-Speed	%	37/23	
		2-Speed	%	46/23	
		Gradeability @ 1 mph RL/NL †† 1-Speed	%	31/23	
		2-Speed	%	37/23	
WT.	31	Weight, Standard Truck (Standard 2-Stg. LFL) NL	lb (kg)	12650 (5738)	
		Weight, Standard Truck (Standard 2-Stg. LFL) RL	lb (kg)	20650 (9367)	
	32	Axle Loading, Static Front/Rear NL	lb (kg)	4797/7853 (2176/3562)	
		Axle Loading, Static Front/Rear RL	lb (kg)	18182/2468 (8247/1119)	
TIRES & WHEELS	33	Tire Size, Front		22 X 9 X16	
	34	Tire Size, Rear		18 X 7 X 12.2	
	35	Wheelbase	in (mm)	61.8 (1570)	
	37	Ground Clearance, Lowest Point NL (with RL subtract	in (mm)	4.5 (114)	
	38	Ground Clearance, Center of Wheelbase NL	in (mm)	6.0 (152)	
	39	Service Brake - Method of Control/Operation		Foot/Hydraulic	
	40	Parking Brake - Method of Control/Operation		Hand/Mechanical	
	41	Battery Type		Maintenance Free	
	POWERTRAIN	42	Volts/Cold Cranking Amps	v/cca	12/475
43		Engine, Manufacturer/Model		Kubota WG3800 LPG	
44		Permanent Output	hp (kW)	74 (55) @ 1800 RPM	
45		Torque @ Rated RPM	ft/lbs (kg/m)	221 (300) @ 1000 RPM	
46		Number of Cylinders/Displacement	No/cc (ci)	4/3769 (230)	
		Standard Speeds, Forward/Reverse		1/1	
49		Hydraulic Tank - capacity (drain & refill)	gal (liter)	20.5 (77.7)	
51		Auxiliary Hydraulic Pressure Relief for Attachments	PSI (Mpa)	2250 (15.5)	

† NOTE: Performance specifications / ratings are for truck equipped as described under Standard Equipment in this Specification Sheet. Performance specifications are affected by the condition of the vehicle and how it is equipped, as well as by the nature and condition of the operating area. Specifications are subject to change and the proposed application should be discussed with your authorized Yale Dealer.

†† Limited by traction. For further information on this dimension, please contact your local Yale dealer.

Above specifications, unless otherwise listed, are for a standard truck without optional equipment.

Right Angle Stack and Equal Intersecting Aisle dimensions provided with a 48" long and 40" wide pallet load, allowing zero clearance.

GENERAL	1	Manufacturer Name		Yale	
	2	Model		GC080VX BCS (Box Car Special)	
		Engine		Kubota 3.8L LPG	
	3	Rated Capacity	lb (kg)	8000 (3629)	
	4	Load Center, Distance	in (mm)	24 (610)	
	5	Power Type		LPG	
	6	Operator Type		Sit-Down Rider	
	7	Step Height	in (mm)	15.6 (396)	
	8	Tire Type - Cushion, Solid, Pneumatic		Cushion	
DIMENSIONS	9	Wheels, Number - Front/ Rear	X driven	2x/2	
	10	Lift Height, Top of Fork (TOF)	in (mm)	120 (3050)	
	11	Lift Heights, Standard Limited Free Lift (LFL) with LBR	in (mm)	6 (150)	
		Lift Heights, Optional Full Free Lift (FFL) with LBR	in (mm)	35 (900)	
	12	Standard Carriage Width	in (mm)	42 (1067)	
	13	Forks, Thickness x Width x Length	in (mm)	2 X 5 X 48 (50 X 125 X 1219)	
	14	Fork Spread, Outside Dimensions	in (mm)	38.3 (972)	
	15	Mast Tilt Angles, Forward/Backward	degrees	5F/6B	
	16	Length To Face of Forks	in (mm)	95.6 (2427)	
	17	Overall Width, Standard Tread	in (mm)	46.1 (1170)	
		Overall Width, Wide Tread	in (mm)	50.0 (1270)	
	18	Height, Standard Mast - Lowered	in (mm)	84 (2134)	
	19	Height, Standard Mast - Extended with LBR	in (mm)	169 (4284)	
		Height, Standard Mast - Extended without LBR	in (mm)	149 (3783)	
	20	Height, Standard Overhead Guard	in (mm)	86 (2171)	
		Height, Optional Overhead Guard	in (mm)	83 (2104)	
	21	Turning Radius, Minimum Outside (OTR)	in (mm)	82.8 (2102)	
	22	Length, Center of Wheel to Face of Forks	in (mm)	17.6 (447)	
	23	Aisle Width, Right Angle Stack (Add Length of Load)	in (mm)	100.4 (2549)	
	24	Equal Aisle, 90-Degree Intersecting Aisle (48" L X 40"	in (mm)	79.4 (2017)	
	PERFORMANCE †	25	Travel Speed RL/NL 1-Speed	mph (km/h)	10.7/10.7 (17.2/17.2)
			2-Speed	mph (km/h)	13.7/13.9 (22.1/22.4)
		26	Lift Speed, Standard 2-Stage LFL RL/NL	ft/min (m/s)	120/122 (.61/.62)
			Lift Speed, Optional 2-Stage FFL RL/NL	ft/min (m/s)	106/108 (.54/.55)
		Lift Speed, Optional 3-Stage FFL RL/NL	ft/min (m/s)	112/114 (.57/.58)	
27		Lowering Speed, Standard 2-Stage LFL RL/NL	ft/min (m/s)	93/108 (.47/.55)	
		Lowering Speed, Optional 2-Stage FFL RL/NL	ft/min (m/s)	71/98 (.36/.50)	
		Lowering Speed, Optional 3-Stage FFL RL/NL	ft/min (m/s)	87/104 (.44/.53)	
28		Max Drawbar Pull RL/NL 1-Speed	lb (kg)	7118/3333 (3229/1512)	
		2-Speed	lb (kg)	8550/3333 (3878/1512)	
		Drawbar Pull @ 1 mph RL/NL 1-Speed	lb (kg)	6159/3333 (2794/1512)	
		2-Speed	lb (kg)	7148/3333 (3242/1512)	
29		Max Gradeability RL/NL †† 1-Speed	%	35/26	
		2-Speed	%	44/26	
		Gradeability @ 1 mph RL/NL †† 1-Speed	%	30/26	
		2-Speed	%	36/26	
WT.		31	Weight, Standard Truck (Standard 2-Stg. LFL) NL	lb (kg)	13340 (6051)
		Weight, Standard Truck (Standard 2-Stg. LFL) RL	lb (kg)	21340 (9680)	
	32	Axle Loading, Static Front/Rear NL	lb (kg)	5555 / 7785 (2520 / 3531)	
		Axle Loading, Static Front/Rear RL	lb (kg)	18940 / 2400 (8591 / 1089)	
TIRES & WHEELS	33	Tire Size, Front		22 X 9 X16	
	34	Tire Size, Rear		18 X 7 X 12.2	
	35	Wheelbase	in (mm)	61.8 (1570)	
	37	Ground Clearance, Lowest Point NL (with RL subtract	in (mm)	4.5 (114)	
	38	Ground Clearance, Center of Wheelbase NL	in (mm)	6.0 (152)	
	39	Service Brake - Method of Control/Operation		Foot/Hydraulic	
	40	Parking Brake - Method of Control/Operation		Hand/Mechanical	
POWERTRAIN	41	Battery Type		Maintenance Free	
	42	Volts/Cold Cranking Amps	v/cca	12/475	
	43	Engine, Manufacturer/Model		Kubota WG3800 LPG	
	44	Permanent Output	hp (kW)	74 (55) @ 1800 RPM	
	45	Torque @ Rated RPM	ft/lbs (kg/m)	221 (300) @ 1000 RPM	
	46	Number of Cylinders/Displacement	No/cc (ci)	4/3769 (230)	
		Standard Speeds, Forward/Reverse		1/1	
	49	Hydraulic Tank - capacity (drain & refill)	gal (liter)	20.5 (77.7)	
	51	Auxiliary Hydraulic Pressure Relief for Attachments	PSI (Mpa)	2250 (15.5)	

† NOTE: Performance specifications / ratings are for truck equipped as described under Standard Equipment in this Specification Sheet. Performance specifications are affected by the condition of the vehicle and how it is equipped, as well as by the nature and condition of the operating area. Specifications are subject to change and the proposed application should be discussed with your authorized Yale Dealer.

†† Limited by traction. For further information on this dimension, please contact your local Yale dealer.

Above specifications, unless otherwise listed, are for a standard truck without optional equipment.

Right Angle Stack and Equal Intersecting Aisle dimensions provided with a 48" long and 40" wide pallet load, allowing zero clearance.

GC080VX MAST DIMENSIONS

Maximum Fork Height	Overall Lowered Height	Overall Extended Height		Free-Lift (TOF)		Tilt
		w/Load Backrest	w/o Load Backrest	w/Load Backrest	w/o Load Backrest	Rwd/Fwd
in (mm)	in (mm)	in (mm)	in (mm)	in (mm)	in (mm)	degrees
2-Stage Limited Free-Lift (LFL) Mast						
120 (3050)	85 (2134)	169 (4284)	149 (3783)	5 (150)	5 (150)	6/5
143 (3650)	96 (2434)	193 (4884)	173 (4383)	5 (150)	5 (150)	6/5
2-Stage Limited Free-Lift (FFL) Mast						
121 (3075)	85 (2134)	170 (4309)	152 (3857)	35 (900)	53 (1352)	6/5
3-Stage Full Free-Lift (FFL) Mast						
173 (4415)	85 (2134)	223 (5649)	205 (5197)	35 (900)	53 (1352)	6/5
185 (4715)	88 (2234)	235 (5949)	217 (5497)	39 (1000)	57 (1452)	6/5
194 (4950)	92 (2334)	244 (6184)	226 (5732)	43 (1100)	61 (1552)	6/5
218 (5550)	100 (2534)	268 (6784)	250 (6332)	51 (1300)	68 (1752)	6/5

Note: GC080VX has standard 22 x 9 x 16 drive tires @ 46.1 inch (1170 mm) overall width.



Hydraulic Power Steering (hydrostatic steering) provides low-effort, responsive control and eliminates mechanical linkages for reduced surface shock and simplified maintenance. The steering wheel is 12 inches in diameter with a textured surface grip and spinner knob, and requires only four turns lock-to-lock. The center mounted steer cylinder is located within the confines of the steer axle for protection.

Steer Axle is constructed of cast steel and is rubber shock mounted to the frame for reduced wear and vibration. The Continuous Stability System (CSS™) enhances lateral truck stability through reduced steer axle articulation, allowing for travel over uneven surfaces.

Chassis designed by state-of-the-art finite element methods contains a rugged, unitized frame structure with a low step for simple entrance to the operator's compartment. Ergonomically designed overhead guard is bar type for good visibility and reduced noise.

Operator's Compartment features cowl-mounted hydraulic control levers positioned on the right side of the steering column. Optional Accutouch mini-lever electro-hydraulic controls are integrated into the operator's right-side armrest allowing improved ergonomic actuation. Automotive-style pedal arrangement with a large, single inch/brake pedal is standard. Tilt cylinders are located beneath the floor for uncluttered space. Rubber floor mat reduces noise and vibration. The floorplate can be removed without tools for excellent service access. Low step height and a convenient hand grip provide easy entry and exit to and from the truck.

Intellix VSM acts as a master truck controller, providing extensive monitoring and control of truck functions and systems. CANbus technology reduces wiring complexity and enables comprehensive communications between truck systems. The ergonomically positioned dash display transmits continual feedback to the operator and allows for communication of service codes. Comprehensive on-board diagnostics enable quick and easy troubleshooting. The electrical system features sealed connectors and Hall Effect sensors for superior dependability.

The Hydraulic System incorporates two hydraulic tanks that provide additional cooling of the hydraulic system. The hydraulic tanks are integrated into the frame. An emergency lowering valve is provided to allow the load to be lowered in the event of power loss. O-ring face seal fittings are used in all high pressure hydraulic connections. Oil is double filtered through a 100 mesh suction line strainer and 10 micron return line filter.

The **optional on-demand hydraulic system** features a variable displacement pump, reducing heat load into the truck by pumping oil only when needed. The drivetrain runs cooler, thereby extending the life of the hydraulic components. The system helps minimize engine power consumed, which can result in greater fuel economy and reduced system temperatures.

Yale Hi-Vis™ Masts are available in 2-stage LFL (Limited Free Lift), 2-stage FFL (Full Free Lift), and 2-stage FFL models. Mast features flush-faced design with geometrically matched, angled load roller bearings which are canted, yet provide full-face roller contact. The mast front rail flange angle coupled with the inverted "J" inner channel and three degree mast rollers significantly reduce channel and roller wear. "J-hook" mast mounting system allows for convenient mast installation and removal. A non-metallic phenolic mast pivot bushing with woven reinforcement offers high load carrying capability with outstanding durability.

Options

- Techtronix transmission
 - Auto deceleration system
 - Controlled power reversal feature
 - Controlled roll back on ramps
- Optional Techtronix two-speed transmission
 - Higher gradeability and drawbar pull performance
 - Additional forward speed
 - Increased travel speeds
- Powertrain protection system
- Premium monitoring package
- High air intake with precleaner
- Accutouch mini-lever, electro-hydraulic control with on-demand hydraulic system
- On-demand cooling system
- Full venting package
- Accumulator
- Keyless start (w/auxiliary key switch)
- LED brake and back-up lights
- Halogen or LED headlights and rear drive lights
- Traction speed limiter
- Swing-out, drop-down EZ-Tank Bracket
- Return-to-set tilt
- Rear drive handle with horn button
- Full-suspension, semi-suspension, or swivel full-suspension seat (vinyl or cloth)
- High-visibility non-cinch seat belt with or without interlock
- Foot Directional Control pedal
- Extension tubes with or without quick disconnect
- 10° forward/5° backward tilt
- Operator password
- Mirrors - dual side view
- Alarm - reverse actuated 82-102 dB(A) - self-adjusting
- Amber strobe light - continuous activated
- Paper applications kit
- 5 function (3 aux) hydraulic control valve
- Seat side directional control
- Impact monitor
- Operator preshift checklist
- Load weight indicator
- Heavy duty premium wet disc brakes



YALE MATERIALS HANDLING CORPORATION

P.O. Box 7367, Greenville, NC 27835-7367

www.yale.com

Yale is a Registered Trademark and  is a Registered Copyright.
©Yale Materials Handling Corporation 2015. All Rights Reserved.

Manufactured in our own ISO 9001 and 14001 Registered Facilities

2228-1C 08/2016 All trucks shown with optional equipment.

Truck performance may be affected by the condition of the vehicle, how it is equipped and the application. Consult your Yale® Industrial Truck Dealer if any of the information shown is critical to your application. Specifications are subject to change without notice.

This truck meets all applicable mandatory requirements of ANSI B56.1 Safety Standard for Powered Industrial Trucks at the time of manufacture. Classified by Underwriters' Laboratories, Inc., as to fire and electric shock hazard only for Type E industrial trucks.

The Yale® products included in this document may be covered by US patent 6,684,148 and other patents pending.