



MSW 025-030F, 040E

SPEC SHEET

High lift straddle
walkie pallet stacker

2,500-4,000 lbs.

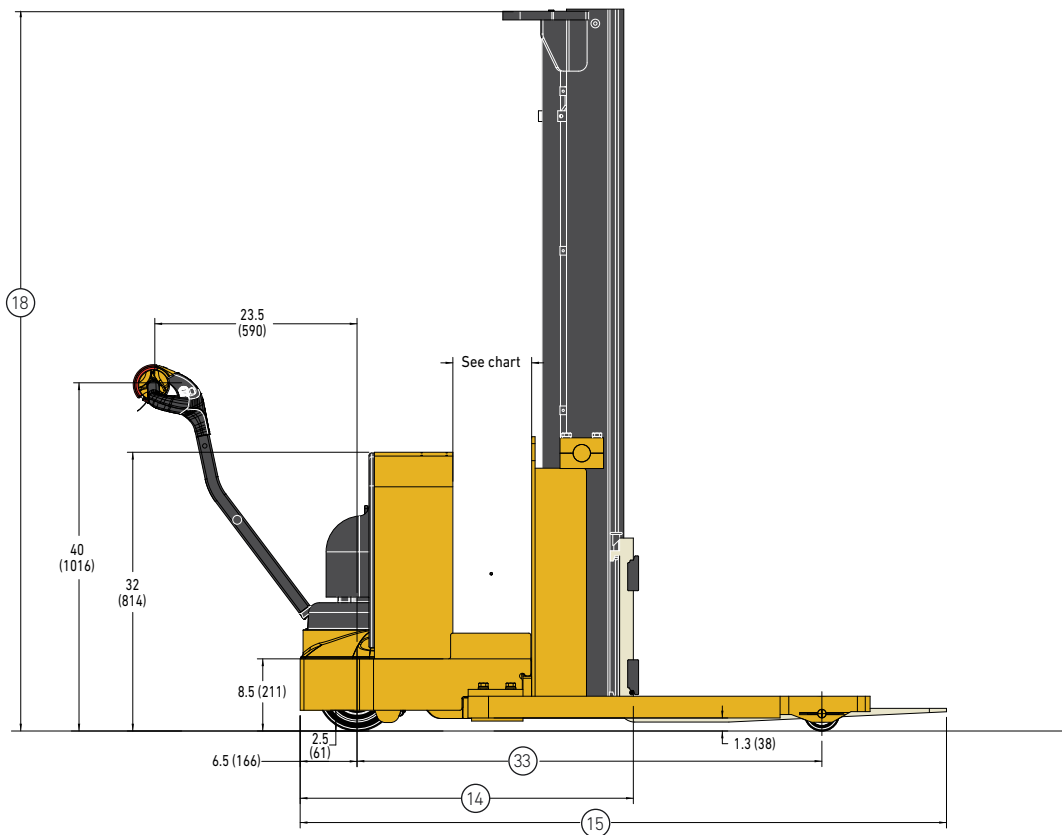

MSW025F Adjustable basearms

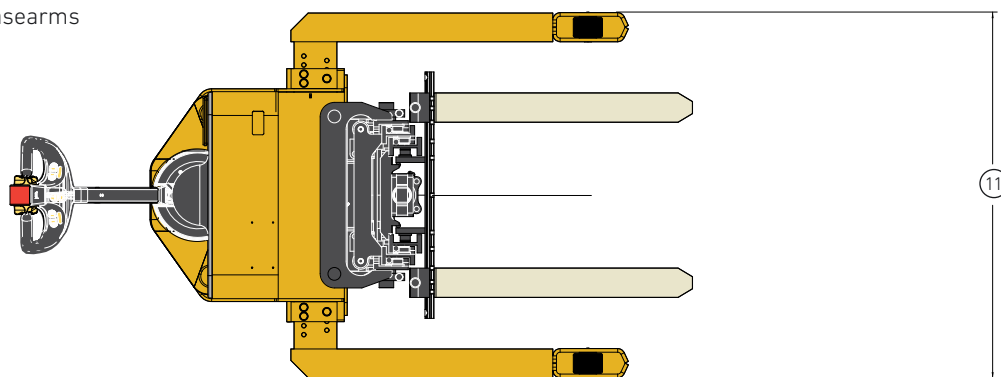

MSW030F Fixed basearms

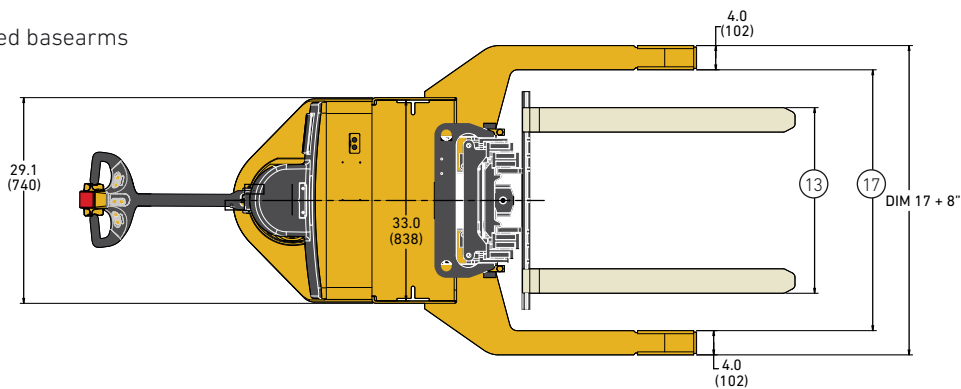

TRUCK DIMENSIONS - MSW040E

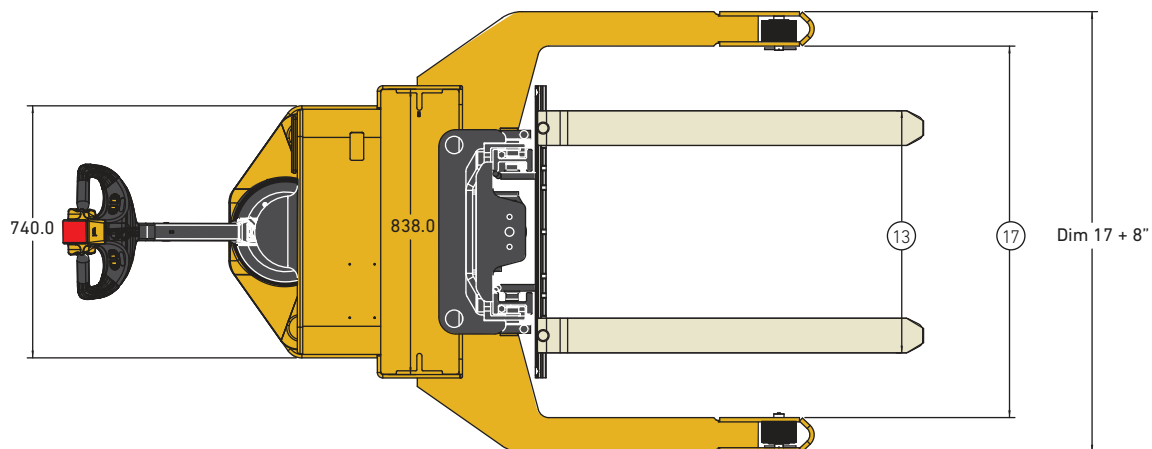
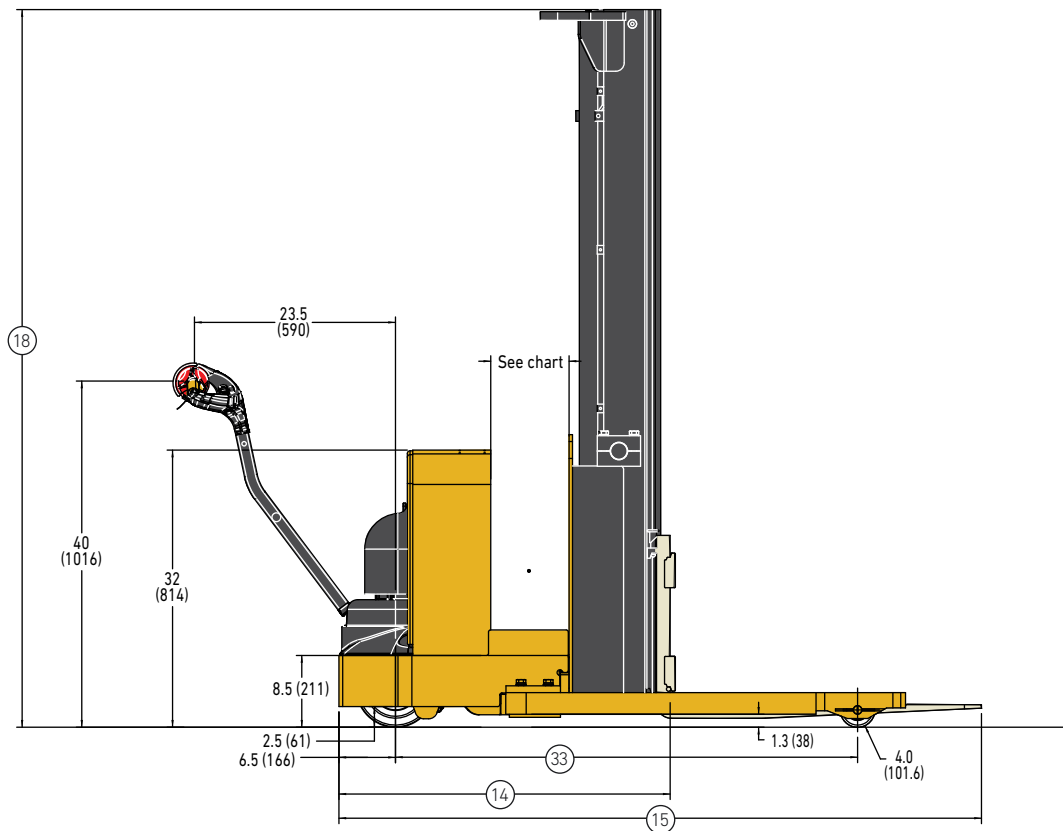

GENERAL SPECIFICATIONS - MSW025F, MSW030F, MSW040E

		Yale®					
GENERAL	1	Manufacturer					
	2	Model		MSW025-F	MSW030-F	MSW040-E	
	3	Rated capacity		lb. (kg)	2500 (1134)	3000 (1361)	4000 (1814)
	4	Load center		in. (mm)	24 (610)	24 (610)	24 (610)
	5	Power			Battery – 24 Volt	Battery – 24 Volt	Battery – 24 Volt
	6	Operation			Pedestrian	Pedestrian	Pedestrian
	7	Tire type, cushion, solid, pneumatic, etc.			Cushion	Cushion	Cushion
	8	Wheels, drive / load			1 / 2	1 / 2	1 / 2
DIMENSIONS	9	Standard mast – lift height (TOF)		in. (mm)	104.0 (2641)	104.0 (2641)	122.0 (3098)
	10	Standard free lift (TOF)		in. (mm)	6.0 (152)	6.0 (152)	6.0 (152)
	11	Carriage width - maximum		in. (mm)	33.7 (857)	33.7 (857)	33.7 (857)
	12	Forks, width / thickness / length		in. (mm)	3.9 / 1.6 / 42.0 (100 / 40 / 1067)	3.9 / 1.6 / 42.0 (100 / 40 / 1067)	3.9 / 1.8 / 42.0 (100 / 45 / 1067)
	13	Fork spread (outside dimension – maximum)		in. (mm)	30.4 (773)	30.4 (773)	30.4 (773)
	14	Length to face of forks	8.0" Battery comprt.	in. (mm)	37.3 (947)	N/A	N/A
		Length to face of forks	9.0" Battery comprt.	in. (mm)	38.3 (973)	38.3 (973)	43.8 (1111)
		Length to face of forks	13.5" Battery comprt.	in. (mm)	N/A	N/A	48.3 (1226)
	15	Overall length with 42" forks	8.0" Battery comprt.	in. (mm)	79.3 (2014)	N/A	N/A
		Overall length with 42" forks	9.0" Battery comprt.	in. (mm)	80.3 (2040)	80.3 (2040)	85.8 (2179)
		Overall length with 42" forks	13.5" Battery comprt.	in. (mm)	N/A	N/A	90.3 (2294)
	16	Outrigger type, adjustable / fixed			Adjustable	Fixed	Fixed
	17	Outrigger dimension, inside dimension		in. (mm)	37.1 / 39.4 / 41.7 / 49.0 (942 / 1002 / 1060 / 1245)	43.0 (1092)	43.0 (1092)
	18	Overall lowered height (OALH)		in. (mm)	72.0 (1829)	72.0 (1829)	83.0 (2109)
	19	Maximum fork height (MFH)		in. (mm)	104.0 (2641)	104.0 (2641)	122.0 (3098)
20	Turning radius, minimum outside		in. (mm)	77.0 (1958)	80.6 (2047)	82.6 (2098)	
21	Right angle stack			See chart	See chart	See chart	
22	Equal intersecting aisle			See chart	See chart	See chart	
23	Stability (comply with ANSI)*			Yes	Yes	Yes	
PERF.	24	Travel speed - maximum	No load / rated load	mph (kph)	3.5 / 3.0 (5.6 / 4.8)	3.5 / 3.0 (5.6 / 4.8)	3.6 / 3.2 (5.8 / 5.1)
	25	Lifting speed	No load / rated load	fpm (m/s)	30.0 / 22.0 (0.15 / 0.11)	30.0 / 20.0 (0.15 / 0.10)	27.5 / 18.6 (0.14 / 0.09)
	26	Lowering speed	No load / rated load	fpm (m/s)	60.0 / 80.0 (0.3 / 0.4)	60.0 / 80.0 (0.30 / 0.41)	60.0 / 80.0 (0.30 / 0.41)
WEIGHTS	27	Gradeability		%	10.0	10.0	10.0
	28	Truck weight (approximate) without battery	No load	lb. (kg)	2305 (1046)	2323 (1054)	2458 (1115)
	29	Axle loading – drive (static w/min. wt. battery)	No load	lb. (kg)	1523 (691)	1650 (748)	1735 (787)
	30	Axle loading – load wheel (static w/min. wt. battery)	No load	lb. (kg)	1092 (495)	1048 (475)	1323 (600)
WHEELS & TIRES	31	Drive tire	Size / type	in.	9.0 x 4.0 Poly	9.0 x 5.0 Poly	10.0 x 5.0 Poly
	32	Load wheel	Size / type	in.	4.0 x 2.8 Poly	4.0 x 2.8 Poly	4.0 x 2.8 Poly
	33	Wheelbase	8.0" Battery comprt.	in. (mm)	53.8 (1367)	N/A	N/A
		Wheelbase	9.0" Battery comprt.	in. (mm)	54.8 (1392)	57.0 (1448)	59.0 (1499)
		Wheelbase	13.5" Battery comprt.	in. (mm)	N/A	N/A	63.6 (1615)
	34	Ground clearance, lowest point	No load	in. (mm)	1.0 (25)	1.0 (25)	0.5 (13)
35	Ground clearance, center of wheelbase	No load	in. (mm)	1.5 (38)	2.0 (51)	2.0 (51)	
BATT.	36	Type			Lead acid	Lead acid	Lead acid
	37	Ampere hours – maximum			255	255	510
	38	Minimum weight		lb. (kg)	375 (170)	375 (170)	600 (272)
MOTORS	39	Traction motor – 60 minute rating		hp (Kw)	2.3 (1.7)	2.3 (1.7)	2.3 (1.7)
	40	Pump motor – S3 rating		hp (Kw)	4.0 (3.0)	4.0 (3.0)	4.0 (3.0)
	41	Traction motor control method			Transistor	Transistor	Transistor
	42	Number of speeds			Infinitely variable	Infinitely variable	Infinitely variable
	43	Relief pressure for attachments		psi (kPA)	N/A	N/A	2900 (19995)
	44	Grade clearance	8.0" Battery comprt.	%	11.0	N/A	N/A
		Grade clearance	9.0" Battery comprt.	%	14.0	14.0	13.9
	Grade clearance	13.5" Battery comprt.	%	N/A	N/A	12.8	

BATTERY AND COMPARTMENT SPECIFICATIONS - MSW025F, MSW030F, MSW040E

Battery type	Number of cells	Cell size	Plates per cell	Capacity 6 hour rate	Battery Dimensions			Weight lb (kg)
					"X"	"Y"	"Z"	
				amp hr (kwh)	in (mm)	in (mm)	in (mm)	lb (kg)
MSW025F								
Standard battery pack				158 (4.0) / 185 AH @ 20 hr rate	28.4 (721)	7.9 (201)	23.9 (607)	310 (141)
GNB PalletPro® battery pack with 25 amp charger				195 (4.4)	27.3 (693)	7.5 (191)	26.4 (671)	375 (170)
Industrial Battery	12	75	5	150 (3.5)	25.3 (643)	6.4 (163)	23.3 (592)	410 (186)
	12	85	5	170 (3.9)	25.3 (643)	6.4 (163)	23.3 (592)	425 (193)
	12	100	5	200 (4.6)	25.3 (643)	6.4 (163)	26.3 (668)	470 (213)
	12	75	7	225 (5.2)	25.7 (653)	8.8 (224)	23.3 (592)	540 (245)
	12	85	7	255 (6.0)	25.7 (653)	8.8 (224)	23.3 (592)	570 (259)
MSW030F								
GNB PalletPro® battery pack with 25 amp charger				195 (4.4)	27.3 (693)	7.5 (191)	26.4 (671)	375 (170)
Industrial battery	12	75	5	150 (3.5)	25.3 (643)	6.4 (163)	23.3 (592)	410 (186)
	12	85	5	170 (3.9)	25.3 (643)	6.4 (163)	23.3 (592)	425 (193)
	12	100	5	200 (4.6)	25.3 (643)	6.4 (163)	26.3 (668)	470 (213)
	12	75	7	225 (5.2)	25.7 (653)	8.8 (224)	23.3 (592)	540 (245)
	12	85	7	255 (6.0)	25.7 (653)	8.8 (224)	23.3 (592)	570 (259)
MSW040E								
Industrial battery	12	75	7	225 (5.2)	25.7 (653)	8.8 (224)	23.3 (592)	540 (245)
	12	85	7	255 (6.0)	25.7 (653)	8.8 (224)	23.3 (592)	570.0 (259)
	12	75	11	375 (8.7)	26.5 (673)	13.0 (330)	23.3 (592)	825.0 (374)
	12	85	11	425 (9.9)	26.1 (663)	12.8 (325)	23.3 (592)	865.0 (392)
	12	75	13	450 (10.5)	30.9 (785)	13.0 (330)	23.3 (592)	987.0 (448)
	12	85	13	510 (11.9)	30.9 (785)	13.0 (330)	23.3 (592)	1035.0 (469)

Battery connector: 175 amp, red

Battery lead: length 20" (508 mm), position "B", 1/0 AWG

STANDARD LIFT SPECIFICATIONS

	Overall lowered ht. in (mm)	Fork height - top of forks in (mm)	Free lift in (mm)	Overall ht. w/LBR in (mm)	Overall ht. w/o LBR in (mm)
MSW025F					
2 Stage LFL	72 (1829)	104 (2641)	6 (152)	152 (3861)	123.5 (3137)
	83 (2109)	126 (3200)	6 (152)	174 (4420)	145.5 (3936)
	87 (2210)	130 (3302)	6 (152)	178 (4522)	149.5 (3798)
	92 (2337)	144 (3657)	6 (152)	192 (4877)	163.5 (4153)
	95 (2413)	150 (3810)	6 (152)	198 (5030)	169.5 (4306)
MSW030F					
2 Stage LFL	72 (1829)	104 (2641)	6 (152)	152 (3861)	123.5 (3137)
	83 (2109)	126 (3200)	6 (152)	174 (4420)	145.5 (3936)
	87 (2210)	130 (3302)	6 (152)	178 (4522)	149.5 (3798)
	92 (2337)	144 (3657)	6 (152)	192 (4877)	163.5 (4153)
	95 (2413)	150 (3810)	6 (152)	198 (5030)	169.5 (4306)
3 Stage FFL	72 (1829)	157 (3987)	50 (1270)	205 (5207)	176.5 (4484)
MSW040E					
2 Stage LFL	72 (1829)	100 (2540)	6 (152)	148 (3760)	119.5 (3036)
	77 (1956)	110 (2794)	6 (152)	158 (4014)	129.5 (3290)
	83 (2109)	122 (3098)	6 (152)	170 (4318)	141.5 (3595)
	87 (2210)	130 (3302)	6 (152)	178 (4522)	149.5 (3798)
	92 (2337)	140 (3556)	6 (152)	188 (4776)	159.5 (4052)
3 Stage FFL	72 (1829)	153 (3886)	48 (1219)	201 (5106)	172.5 (4382)
	77 (1956)	168 (4267)	53 (1346)	216 (5487)	187.5 (4763)
	83 (2109)	186 (4724)	59 (1498)	234 (5944)	205.5 (5220)

RIGHT ANGLE STACK

MSW025F with 8" BC							
Without Creep Mode Engaged				With Creep Mode Engaged			
Load Width	Load Length			Load Width	Load Length		
	36	40	48		36	40	48
36	82.5	82.5	82.5	36	64.4	64.4	64.4
40	83.3	83.3	83.3	40	64.8	64.8	64.8
48	84.4	84.4	84.4	48	69.4	69.4	69.4

MSW025F with 9" BC							
Without Creep Mode Engaged				With Creep Mode Engaged			
Load Width	Load Length			Load Width	Load Length		
	36	40	48		36	40	48
36	83.5	83.5	83.5	36	65.4	65.4	65.4
40	84.2	84.2	84.2	40	66.3	66.3	66.3
48	85.3	85.3	85.3	48	70.0	70.0	70.0

MSW025F with 9" BC							
Without Creep Mode Engaged				With Creep Mode Engaged			
Load Width	Load Length			Load Width	Load Length		
	36	40	48		36	40	48
36	85.6	85.6	85.6	36	67.4	67.4	67.4
40	86.5	86.5	86.5	40	68.5	68.5	68.5
48	87.4	87.4	87.4	48	71.3	71.3	71.3

MSW040E with 13.5" BC							
Without Creep Mode				With Creep Mode			
Load Width	Load Length			Load Width	Load Length		
	36	40	48		36	40	48
36	87.6	95.3	95.3	36	72.5	80.1	80.1
40	90.3	96.1	96.1	40	75.4	81.0	81.0
48	91.2	96.9	96.9	48	76.4	82.0	82.0

INTERSECTING AISLE LAYOUT

MSW025F with 8" BC								
Without Creep Mode Engaged					With Creep Mode Engaged			
Load Width	Load Length			Load Width	Load Length			
	36	40	48		36	40	48	
36	63.1	63.1	63.1	36	56.3	56.3	56.3	
40	65.5	65.5	65.5	40	58.4	58.4	58.4	
48	68.9	68.9	68.9	48	61.6	61.6	61.6	

MSW025F with 9" BC								
Without Creep Mode Engaged					With Creep Mode Engaged			
Load Width	Load Length			Load Width	Load Length			
	36	40	48		36	40	48	
36	63.7	63.7	63.7	36	56.9	56.9	56.9	
40	66.1	66.1	66.1	40	59.5	59.5	59.5	
48	69.5	69.5	69.5	48	62.3	62.3	62.3	

MSW025F with 9" BC								
Without Creep Mode Engaged					With Creep Mode Engaged			
Load Width	Load Length			Load Width	Load Length			
	36	40	48		36	40	48	
36	65.0	65.0	65.0	36	58.5	58.5	58.5	
40	67.9	67.9	67.9	40	61.1	61.1	61.1	
48	70.8	70.8	70.8	48	63.8	63.8	63.8	

MSW040E with 13.5" BC								
Without Creep Mode					With Creep Mode			
Load Width	Load Length			Load Width	Load Length			
	36	40	48		36	40	48	
36	69.0	68.0	70.0	36	61.0	60.0	62.0	
40	72.0	71.0	73.0	40	64.0	63.0	65.0	
48	72.0	74.0	76.0	48	64.0	66.0	68.0	

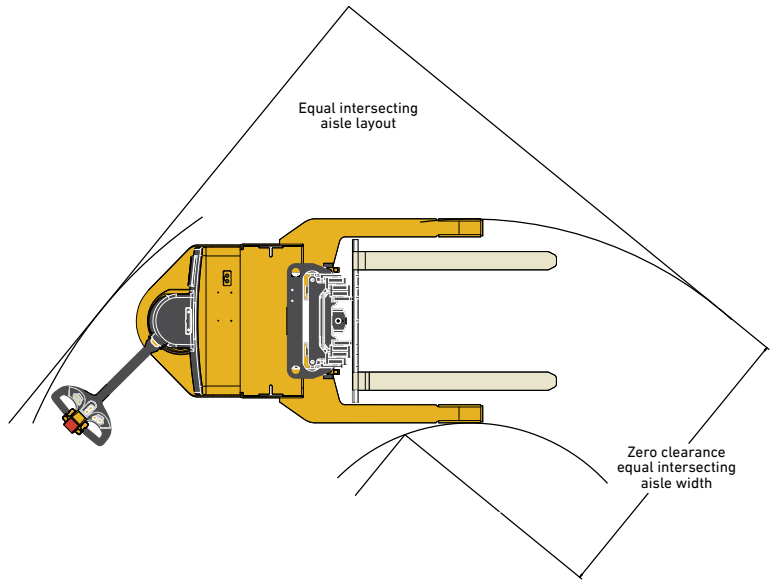
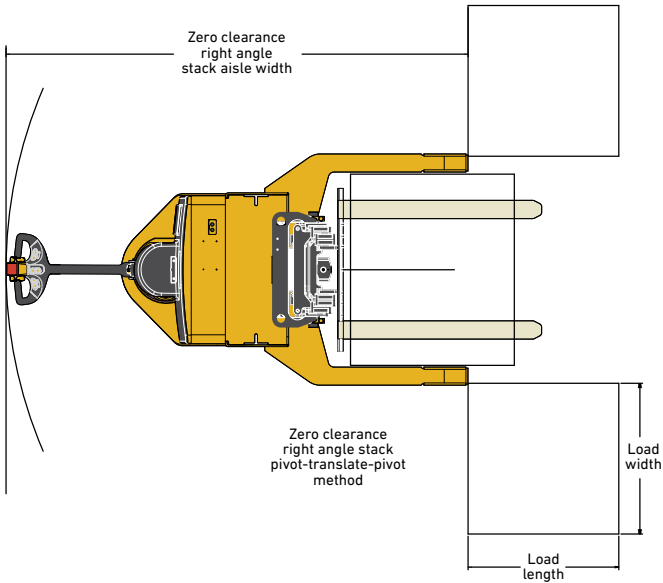

FEATURES LIST - MSW025F, MSW030F, MSW040E

PERFORMANCE	STD	OPT
24 Volt	●	
SEM traction control technology	●	
Energy efficient MOSFET traction/hoist controller	●	
Transistor hydraulics	●	
Auto deceleration system	●	
3 User programmable performance modes		
Creep speed control		●
DRIVE	STD	OPT
Drive tire (MSW025-F)		
- 9" x 4" molded-on polyurethane	●	
- 9" x 4" molded-on rubber		●
- 9" x 5" press-on smooth rubber		●
- 9" x 5" press-on non-marking rubber		●
- 9" x 5" press-on micro-siped polyurethane		●
- 9" x 5" press-on polyurethane		●
Drive tire (MSW030F)		
- 9" x 5" press-on polyurethane	●	
- 9" x 5" press-on micro-siped polyurethane		●
- 9" x 5" press-on non-marking rubber		●
Drive tire (MSW040E)		
- 10" x 5" press-on polyurethane	●	
- 10" x 5" press-on rubber		●
Load wheels		
4" x 2.8" single polyurethane load wheels	●	
4" x 2.8" tandem polyurethane load wheels (MSW040E only)		●
LIFT	STD	OPT
Mast		
- 104" MLH / 72" OLH 2- stage	●	
- 126" MLH / 83" OLH 2- stage		●
- 130" MLH / 87" OLH 2- stage		●
- 144" MLH / 92" OLH 2- stage		●
- 150" MLH / 95" OLH 2- stage		●
- 157" MLH / 72" OLH 3- stage (MSW030F only)		●
Mast (MSW040-E)		
- 100" MLH / 72" OLH 2- stage		●
- 110" MLH / 77" OLH 2- stage		●
- 122" MLH / 83" OLH 2-stage	●	
- 130" MLH / 87" OLH 2- stage		
- 140" MLH / 92" OLH 2- stage		●
- 153" MLH / 72" OLH 3- stage		●
- 168" MLH / 77" OLH 3- stage		●
- 186" MLH / 83" OLH 3- stage		●
Two speed lift / lower	●	
Proportional lift/lowering (MSW040E standard)		●
HANDLING	STD	OPT
33.75" Carriage	●	
34" hook type integral sidesift carriage		●
48" high load backrest extension	●	
Without load backrest		●
Forks		
- 36" x 1.5" x 3.9" hook type - standard taper forks		●
- 42" x 1.6" x 3.9" hook type - standard taper forks	●	
- 48" x 1.6" x 3.9" hook type - standard taper forks		●
Forks (MSW040E)		
- 36" x 1.75" x 4.0" hook type - standard taper forks		●
- 42" x 1.75" x 4.0" hook type - standard taper forks	●	
- 48" x 1.75" x 4.0" hook type - standard taper forks		●
Without forks		●
ERGONOMICS	STD	OPT
Ergonomically designed composite control handle	●	
Ergonomically designed cast aluminum control handle		●
OPERATION	STD	OPT
Key switch start	●	
Keyless toggle start with auxiliary key switch		●

OPERATION (CONTINUED)	STD	OPT
Outriggers		
- 37" Open end clearance with 45" outside dimension (overall width) - (MSW040E only)	●	
- 42" Open end clearance with 50" outside dimension (overall width)* - (MSW025F only)	●	
* adjustable 37", 39.4", 42", 49" open end clearance (MSW025F)		
- 43" Open end clearance w/ 51" outside dimension (overall width)	●	
- 49" Open end clearance w/ 57" outside dimension (overall width)		●
Audible alarm self adjusting 82-102db(A)		
- Forward and reverse activated		●
- Motion alarm - forward, reverse, lift, lower activated		●
Battery connector		
- 175 amp red	●	
- 175 amp grey		●
- X-type 175 amp red (MSW025F only)		●
Multi-function display		
- Battery discharge indicator		●
- Hour meter		●
- Fault light		●
- lift interrupt		●
Electric horn	●	
Electro-magnetic park brake	●	
Traction reversing switch	●	
SUPPLEMENTAL	STD	OPT
12 Months / no limit full truck warranty	●	
36 months / 6,000 hours powertrain warranty	●	
60 months / 10,000 hour frame warranty	●	
3 year 6,000 hour part A comprehensive parts and labor no deduct		●
5 year 10,000 hour part A comprehensive parts and labor no deduct		●
5 year 10,000 hour part B powertrain parts and labor no deduct		●
HY-Shield - part A extension to 3 years / 6,000 hours - part B extension to 5 years / 10,000 hours		●
Parts manual		
- CD		●
- printed		●
CONSTRUCTION	STD	OPT
UL Classification Type "E"	●	
Application/environmental Construction		
- Standard environmental construction +320F	●	
- Cold storage/freezer package to -150F		●
Battery compartment		
- 8.0" x 28.3" (MSW025F only)		●
- 9.0" x 28.3" (MSW025F only)	●	
- 9.0" x 32.9" (MSW030F)	●	
- 13.5" x 33" (MSW040E)	●	
Lift out battery removal	●	
Side Battery Extraction (MSW040-E only)		●
VISIBILITY	STD	OPT
Wire mesh screen	●	
Lexan shield - mast		●
Amber strobe light		
- Forward and reverses activation		●
- Reverse activation		●
- continuous operation with key-on		●
ENERGY SYSTEM	STD	OPT
Set for flooded cell	●	
Set for maintenance free		●
110V 195AH/60HZ GNB Champion Pallet Pro maintenance free battery with on-board charger ((MSW025-030-F only)		●
170AH/50-60Hz flooded cell battery power pack with 20AMP high frequency smart charger (MSW025-F only)		●
110V 187AH/50-60HZ AGM maintenance free battery with 20 AMP high frequency smart charger (MSW025-F only)		●
Without battery		●

About Yale



Yale Lift Truck Technologies leverages over a century of material handling experience and substantial investment in innovation to bring the most advanced technology-driven lift truck solutions to market. The company offers a full line of award-winning lift trucks, including reach trucks, order pickers, turret trucks, pallet jacks and trucks, pallet stackers, tow tractors and counterbalanced forklifts, as well as powerful operator assist solutions, proven robotics and a wide range of power sources to help customers adapt to today's demanding supply chain. Yale and its independent dealer network support these solutions with comprehensive after-sales service, parts, financing and training.

MATERIALS HANDLING FOR:

Third-party logistics (3PL)

Auto parts distribution

Beverage

Cold & frozen foods

Food distribution

Food processing

Furniture & furnishings

Government

Health & pharma

Home centers & durables

Retail & e-commerce

Yale Lift Truck Technologies
P.O. Box 7367
Greenville, NC 27835-7367
U.S.A.

yale.com



EXPLORE MORE
ONLINE.
←

© 2023 Hyster-Yale Group, Inc., all rights reserved. YALE and  are trademarks of Hyster-Yale Group, Inc.

Trucks may be shown with optional equipment and/or features not available in all regions. Truck performance may be affected by the condition of the vehicle, how it is equipped and the application. Specifications are subject to change without notice. Consult your Yale® Dealer if any of the information shown is critical to your application.

CERTIFICATION: Yale lift trucks meet the design and construction requirements of B56.1-1969, per OSHA Section 1910.178(a)(2), and also comply with the B56.1 revision in effect at time of manufacture. Classified by Underwriters' Laboratories, Inc.