

# Yale

## Low Lift Pallet Walkie **MPW080-E**

**Yale** motorized hand trucks combine the latest in state-of-the-art technology and ergonomics making Yale the leader for walkie applications.

### Controls

Travel direction and speed are selected by rotating the actuator in the desired direction of travel. The butterfly throttle control provides multiple grip positions minimizing operator fatigue. The stationary portion of the handle minimizes wrist movement and provides a solid grip while maneuvering the truck. This provides additional stability while driving the truck. The bottom-mounted tiller handle optimizes the operating position.

Lift, Lower, and Horn pushbuttons are conveniently located on the handle.

The Reversing Switch located on top of the handle simultaneously reverses truck direction and sounds the horn should it come in contact with the operator. The wrap around design provides protection through the full range of handle movement. This switch is reset when the direction control is returned to neutral or the handle is moved to the brake "on" position.

### Electrical System

The electrical system utilizes SEM technology with integral hoist control. Separately Excited Motor (SEM) provides the ability to control the traction motor fields and armature independently. This results in enhanced performance and battery efficiency. In combination with the Metal Oxide Semiconductor Field Effect Transistor (MOSFET) motor controller we have reduced wearable components and improved performance. The SEM control system provides higher top speeds when loaded and improved acceleration. Variable regenerative braking occurs when the throttle control is reversed. Regenerative braking improves traction motor brush life and puts energy back into the battery. The controller has neutral braking to decelerate the truck when operating on a ramp. The controller senses when the truck is stopped and automatically applies the brake. The controller has a programmable setup including parameters for acceleration, throttle braking and top travel speed. Diagnostic information can be read using a hand-held programmer tool or by looking at the status of the LED indicator mounted on the controller. A solid-state circuit is used to control the pump motor and eliminates the lift contactor. Lift motor cut-out at full height is controlled electronically through the controller.

### Traction System

The traction system consists of the traction motor, gearbox, and brake. The UL listed traction motor with premium brushes and Class H insulation provides maximum thermal protection. The innovative gear box design incorporates maintenance-free steer bearings, a stationary mounted traction motor, integrated motor pinion, and drive axle string guard. The maintenance-free steer bearings are sealed within the gearbox housing and lubricated by the gear oil. The stationary traction motor eliminates power cable tension and flex. The integral pinion and support bearings optimize the gear mesh resulting in a quieter gearbox. The splined coupling allows for quick removal and installation of the traction motor. The drive axle string guard minimizes axle seal damage from shrink-wrap, banding, etc. The electronically

released, mechanically applied brake is mounted on the top of the traction motor for ease of inspection and maintenance.

### Hydraulic Components

The high performance hydraulic system is designed for high cycle, multi-shift operations. The hydraulic power pack features a series wound motor and translucent hydraulic tank. The series wound motor provides high torque, low noise and is easily serviceable. The translucent tank provides quick and easy inspection of hydraulic oil level.

### Forks and Frame

Robotically welded steel forks are formed and fabricated for strength and rigidity. The 1" x 2" pull rods and replaceable threaded ends allow for easy fork adjustment. Pull rod adjustment can be easily made from the top of the fork.

### Pallet Entry and Exit

Yale fork design provides industry leading pallet entry and exit of both standard and non-standard pallets. The pallet entry/exit system consists of a tapered fork nose, exit runners, and a center roller.

### Wheels, Tires, and Casters

The standard load wheel configuration is a single load wheel with four roller bearings for high load, high speed applications. A "knock-out" axle provides for quick and easy maintenance.

A 10" diameter polyurethane drive tire is standard. The drive wheel is secured to the drive axle with 5 bolts.

### Additional Features

Lubrication – Fill and drain plugs are provided. All frame lubricating points are equipped with high pressure grease fittings. Battery connector – Standard is (red) SB 175 amp connector. Standard equipment includes key switch and an electronic horn.

Paint – Gold and black.

### Options

- UL Type EE Construction
- Severe freezer/food processing package
- Various fork lengths
- Load backrest
- Creep speed control
- Operator convenience tray
- Multi-function display with hour meter, discharge indicator and status code readout
- Battery rollers

### Lift Specifications

6.0" lift 8000 lb. capacity.

### Weight

MPW080-E – 1060 lb (481 kg)

### Power Voltage

MPW080-E – 8000 lb. cap. – 24V STD.

### Travel Speeds

		24 volts	
		mile/h	km/h
8000 lb	Empty	3.6	5.8
	Loaded	2.4	3.9

### Load Wheel Positioning

The load wheels of standard trucks handling single pallets (A) will drop in the last opening of the pallet furthest from the operator when the pallet(s) length equals that of the forks. This opening must be at least nine inches in length and begin six inches from the end of the pallet. If the opening is less, the truck's lift height must be reduced depending on the opening width or the wheels will push-off the bottom boards. Contact your Yale Industrial Truck Dealer for details.



**Truck performance may be affected by the condition of the vehicle, how it is equipped, and the application. Consult your Yale Industrial Truck Dealer if any of the information shown is critical to your application. Specifications are subject to change without notice.**

This truck meets all design specifications of ANSI B56.1 Safety Standard for Powered Industrial Trucks at the time of manufacture. Classified by Underwriters' Laboratories, Inc. as to fire hazard only for Type E industrial trucks.

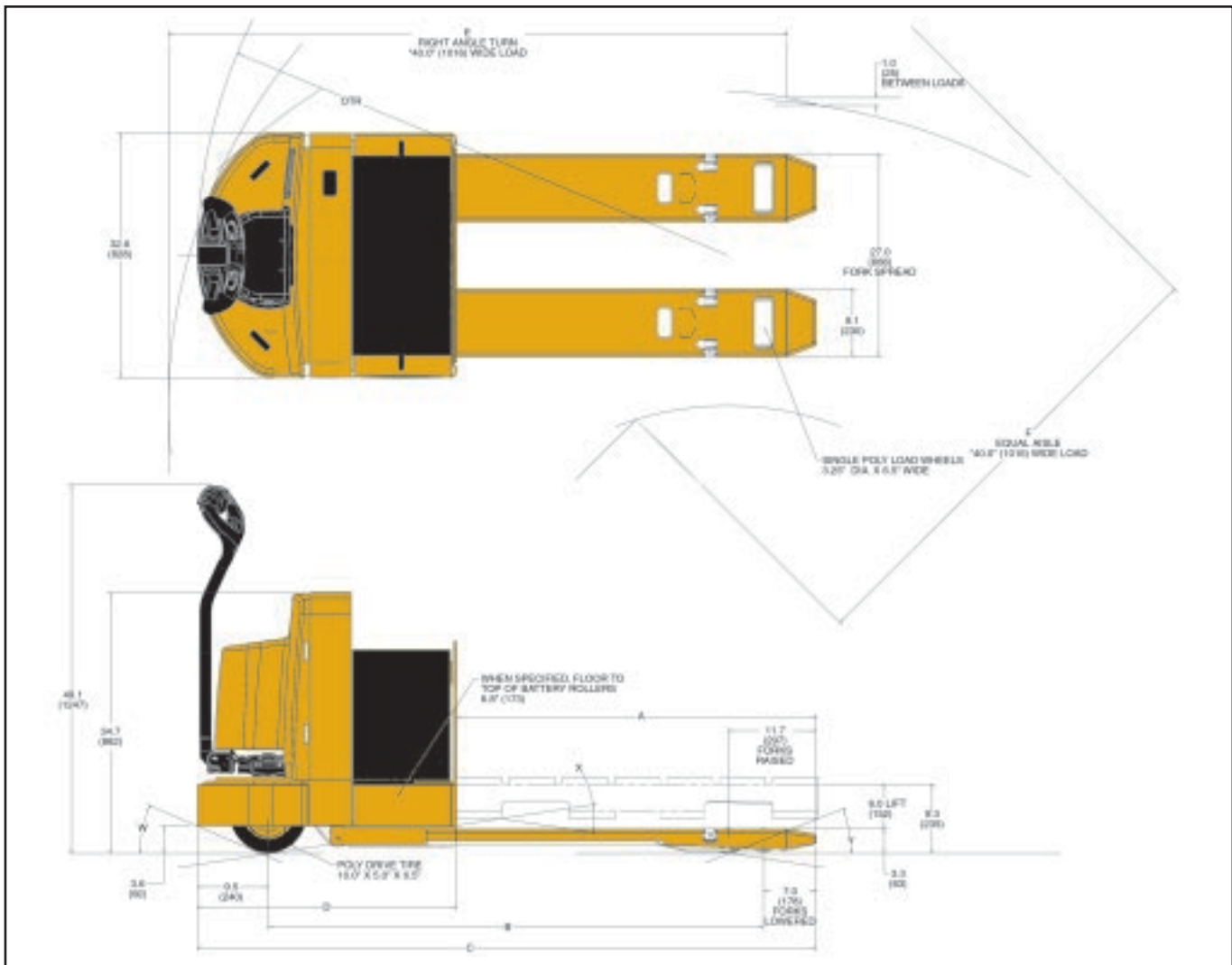

### 24V, 8,000 Lbs. Capacity Walkie

No. of cells	Cell Size	Plates per Cell	Capacity (6 hr rate)		"X" Dim.	"Y" Dim.	"Z" Dim.	Max. Weight
			Amp-Hours	KWH				
12	75	11	375	8.7	26.5"	13.0"	23.3"	825 lbs.
12	85	11	425	9.9	26.1"	12.8"	23.3"	865 lbs.
12	75	13	450	10.5	30.9"	13.0"	23.3"	987 lbs.
12	85	13	510	11.9	30.9"	13.0"	23.3"	1035 lbs.
12	100	13	600	14.0	30.9"	13.0"	26.2"	1140 lbs.

**Notes:** 1) Steel tray with cover required for all batteries, 2) Battery connector type is SB-175, Red for 24 volt (Gray is optional), 3) Cable lead position "B", 4) 20" cable length, 5) Maximum cable gauge of 1/0

### Aisle Layout Dimensions

BATTERY COMPARTMENT: 32.0 (812) X 13.4 (340) DEPTH X OPEN												
	DIM		LONG WHEELBASE		LONG WHEELBASE		LONG WHEELBASE		LONG WHEELBASE		LONG WHEELBASE	
			IN	MM	IN	MM	IN	MM	IN	MM	IN	MM
FORK LENGTH	A		36.0	915	42.0	1067	48.0	1219	54.0	1372	60.0	1524
WHEELBASE	B*	RAISED	49.1	1247	55.1	1400	61.1	1552	67.1	1704	73.1	1857
		LOWERED	53.8	1367	59.8	1519	65.8	1671	71.8	1824	77.8	1976
OVERALL LENGTH	C*		70.2	1783	76.2	1935	82.2	2088	88.2	2240	94.2	2393
CHASSIS LENGTH	D*		34.4	874	34.4	874	34.4	874	34.4	874	34.4	874
OUTSIDE TURNING RADIUS	OTR	RAISED	58.5	1486	64.5	1638	70.5	1791	76.5	1943	82.5	2096
		LOWERED	63.2	1605	69.2	1758	75.2	1910	81.2	2062	87.2	2215
RIGHT ANGLE STACKING	E*		71.2	1808	76.6	1946	82.1	2085	87.7	2228	93.6	2377
GRADE CLEARANCE	F		56.5	1435	59.8	1519	62.9	1598	66.0	1676	68.9	1750
	W		42%		42%		42%		42%		42%	
	X		39%		34%		31%		28%		26%	
	Y		39%		39%		39%		39%		39%	

\*Subtract 4.4" when optional 9" battery box is chosen.