



# MR 14-25, 16N, 16-20HD

SPEC SHEET

Indoor moving mast  
reach truck

---

3,000-5,500 lbs.

**TRUCK DIMENSIONS - MR14, MR16, MR16N, MR20, MR25, MR16HD, MR20HD**

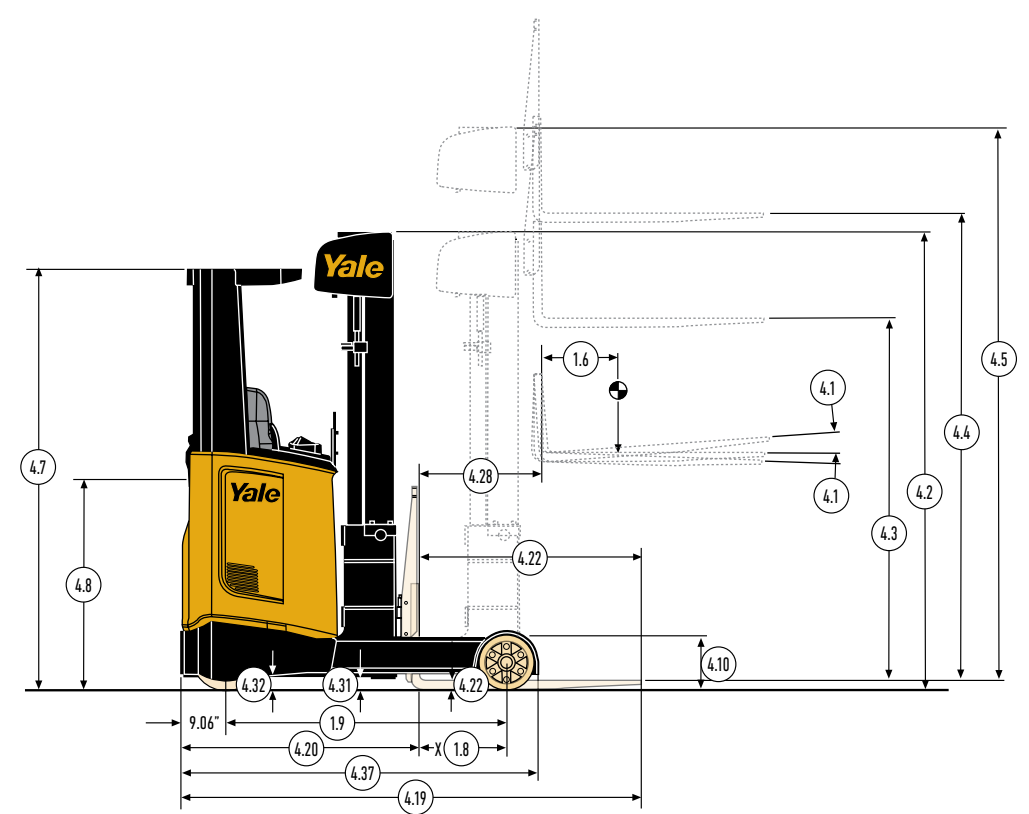

$a = \text{Clearance} = 8"$   
 $L6 = \text{Load length}$   
 $b12 = \text{Load width}$   
 $AST = Wa + R + a$   
 $AST = \text{Right Angle Stack}$

$$R = \sqrt{\left(\frac{L6 - X}{2}\right)^2 + \left(\frac{b12}{2}\right)^2}$$

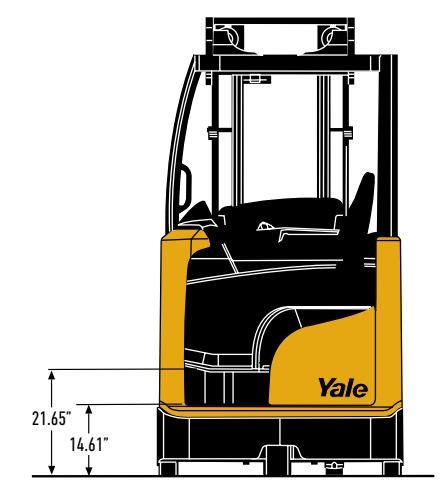

$B1 = \text{Overall Width (Operator Side)}$   
 $B2 = \text{Overall Width (Mast Side)}$   
 $B4 = \text{Width Inside Straddle}$

Circled dimensions correspond to the line numbers on the tabulated chart inside the spec sheet. Dimensions are in inches (millimeters).

All AST dims provided include 8" of total clearance

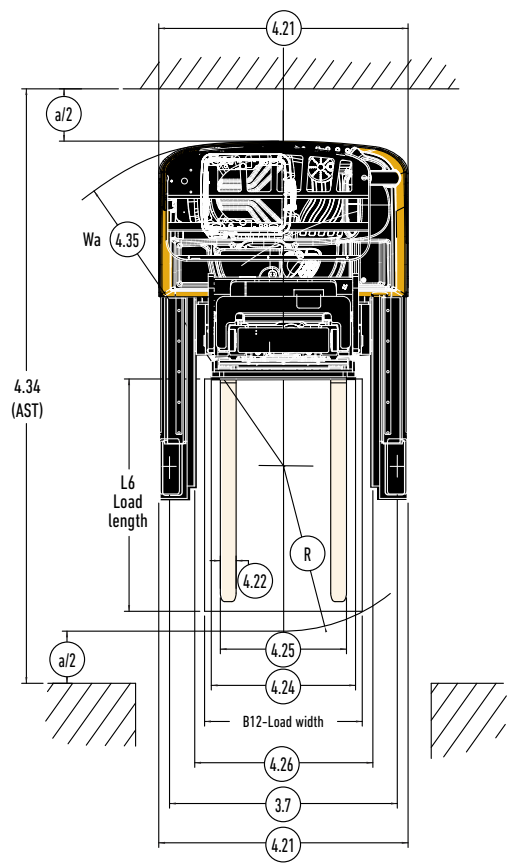

**GENERAL SPECIFICATIONS - MR14, MR16, MR16N, MR16HD**

GENERAL		Yale	Yale	Yale	Yale
1.1	Manufacturer (abbreviation)	Yale	Yale	Yale	Yale
1.2	Manufacturer's type designation	MR14	MR16	MR16N	MR16HD
1.3	Drive: electric, diesel, gasoline, LPG	Electric (battery)	Electric (battery)	Electric (battery)	Electric (battery)
1.4	Operator type	Seated	Seated	Seated	Seated
1.5	Rated capacity/ rated load	3000 (1400)	3500 (1600)	3500 (1600)	3500 (1600)
1.6	Load center distance	24 (600)	24 (600)	24 (600)	24 (600)
1.8	Load distance, center of drive axle to fork <sup>9,10,15,16</sup>	15.83 (402)	17.80 (452)	15.04 (382)	12.13 (308)
1.9	Wheelbase	55.12 (1400)	57.09 (1450)	57.09 (1450)	57.09 (1450)
2.1	Service weight	6861 (3112)	6971 (3162)	6859 (3111)	8902 (4038)
2.3	Axle loading, NL front/rear <sup>4</sup>	4359/2502 (1977/1135)	4449/2522 (2018/1144)	4237/2621 (1922/1189)	5329/3574 (2417/1621)
2.4	Axle loading fork advanced, RL front/rear	1504/8444 (682/3830)	1325/9176 (601/4162)	1254/9132 (569/4142)	1947/10483 (883/4755)
2.5	Axle loading fork retracted, RL front/rear	3920/6030 (1778/2735)	4085/6413 (1853/2909)	3704/6684 (1680/3032)	4788/7641 (2172/3466)
3.1	Tires, front/rear	NDIltthane/NDIltthane	NDIltthane/NDIltthane	NDIltthane/NDIltthane	NDIltthane/NDIltthane
3.2	Tire size, front	13.5 x 5.5 (343 x 140)	13.5 x 5.5 (343 x 140)	13.5 x 5.5 (343 x 140)	13.5 x 5.5 (343 x 140)
3.3	Tire size, rear	11.2 x 3.9 (285 x 100)	11.2 x 3.9 (285 x 100)	11.2 x 3.9 (285 x 100)	11.2 x 3.9 (285 x 100)
3.5	Wheels, number front/rear (x = driven wheels)	1x/2	1x/2	1x/2	1x/2
3.7	Tread, rear	45.47 (1155)	45.47 (1155)	40.35 (1025)	45.47 (1155)
4.1	Tilt of mast/fork carriage forward/backward	2/4	2/4	2/4	2/4
4.2	Height of mast, lowered	See Mast Tables	See Mast Tables	See Mast Tables	See Mast Tables
4.3	Free lift	See Mast Tables	See Mast Tables	See Mast Tables	See Mast Tables
4.4	Lift	See Mast Tables	See Mast Tables	See Mast Tables	See Mast Tables
4.5	Height, mast extended <sup>1</sup>	See Mast Tables	See Mast Tables	See Mast Tables	See Mast Tables
4.7	Height of overhead guard (cabin) <sup>2,14</sup>	85.63 (2175)	85.63 (2175)	85.63 (2175)	85.63 (2175)
4.8	Seat height relating to SIP	42.60 (1082)	42.60 (1082)	42.60 (1082)	42.60 (1082)
4.10	Height of wheel arms	12.13 (308)	12.13 (308)	12.13 (308)	12.13 (308)
4.19	Overall length	93.66 (2379)	93.66 (2379)	96.40 (2449)	99.31 (2523)
4.20	Length to face of forks <sup>15,16</sup>	48.39 (1229)	48.39 (1229)	51.14 (1299)	54.06 (1373)
4.21	Overall width <sup>3,12,13</sup>	49.80 (1265)	49.80 (1265)	44.29 (1125)	49.80 (1265)
4.22	Fork dimensions DIN ISO 2331	1.6/3.1/45.3 (40/80/1150)	1.6/4.7/45.3 (40/120/1150)	1.6/4.7/45.3 (40/120/1150)	1.6/4.7/45.3 (40/120/1150)
4.23	Fork carriage ISO 2328, class/type A, B	2A	2A	2A	2A
4.24	Fork carriage width	27.56 (700)	27.56 (700)	27.56 (700)	27.56 (700)
4.25	Distance between fork arms, min/max <sup>7</sup>	8.66/25.20 (220/640)	10.24/26.77 (260/680)	10.24/26.77 (260/680)	10.24/26.77 (260/680)
4.26	Distance between wheel arms/loading surfaces	35.43 (900)	35.43 (900)	31.30 (795)	35.43 (900)
4.28	Reach distance	23.03 (585)	25.0 (635)	22.24 (565)	19.33 (491)
4.31	Ground clearance, RL, below mast	2.95 (75)	2.95 (75)	2.95 (75)	2.96 (75)
4.32	Ground clearance, center of wheelbase	3.35 (85)	3.35 (85)	3.35 (85)	3.35 (85)
4.34.1	Aisle width for pallets 39.3"x47.2" (1000mm x 1200mm) across - (L6 x b12) <sup>11,15,16</sup>	107.0 (2718) - See Charts	107.5 (2731) - See Charts	108.7 (2762) - See Charts	111.57 (2834) - See Charts
4.34.2	Aisle width for pallets 31.5"x47.2" (800mm x 1200mm) lengthwise - (b12 x L6) <sup>11,15,16</sup>	108.8 (2764) - See Charts	108.9 (2767) - See Charts	110.7 (2811) - See Charts	114.02 (2896) - See Charts
4.35	Turning radius (Wa)	65.79 (1671)	67.64 (1718)	66.93 (1700)	67.64 (1718)
4.37	Length across wheel arms	70.67 (1795)	72.64 (1845)	72.64 (1845)	72.64 (1845)
4.42	Step height (from ground to running board)	21.65 (550)	21.65 (550)	21.65 (550)	21.65 (550)
4.43	Step height (between intermediate steps between running board and floor)	14.61 (371)	14.61 (371)	14.61 (371)	14.61 (371)
5.1	Travel speed, RL   NL <sup>6</sup>	6.8/6.8 (11/11) {8.7/8.7 (14/14)}	6.8/6.8 (11/11) {8.7/8.7 (14/14)}	6.8/6.8 (11/11) {8.7/8.7 (14/14)}	8.7/8.7 (14/14)
5.1.1	Travel speed, RL   NL, backwards <sup>6</sup>	6.8/6.8 (11/11) {8.7/8.7 (14/14)}	6.8/6.8 (11/11) {8.7/8.7 (14/14)}	6.8/6.8 (11/11) {8.7/8.7 (14/14)}	8.7/8.7 (14/14)
5.2	Lift speed, RL   NL <sup>6</sup>	72.8/124 (0.37/0.63) {92.5/143.7 (0.47/0.73)}	63/124 (0.32/0.63) {82.7/143.7 (0.42/0.73)}	63/124 (0.32/0.63) {82.7/143.7 (0.42/0.73)}	82.7/143.7 (0.42/0.73)
5.3	Lowering speed, RL/NL	108.3 (0.55/0.55)	108.3 (0.55/0.55)	108.3/108.3 (0.55/0.55)	108.3/108.3 (0.55/0.55)
5.4	Reaching speed, RL/NL	33.5/33.5 (0.17/0.17)	33.5/33.5 (0.17/0.17)	33.5/33.5 (0.17/0.17)	33.5/33.5 (0.17/0.17)
5.7	Gradeability, RL/NL <sup>6,17</sup>	7/10 {15/20}	7/10 {15/20}	7/10 {14/20}	12/18
5.8	Max. gradeability RL/NL <sup>17</sup>	15/20	15/20	14/20	12/18
5.10	Service brake	Electric	Electric	Electric	Electric
6.1	Drive motor, S2 60 minute rating	9.6	9.6	9.6	9.6
6.2	Lift motor, S3 15% rating	14	14	14	14
6.4	Battery voltage/nominal capacity	(V)/(Ah) 48/420 <sup>5</sup>	48/420 <sup>5</sup>	48/420 <sup>5</sup>	48/560 <sup>5</sup>
6.5	Battery weight <sup>8</sup>	1653 (750)	1653 (750)	1653 (750)	2070 (939)
8.1	Type of drive unit	AC	AC	AC	AC
10.1	Operating pressure for attachments	180	180	180	180
10.2	Oil volume for attachment	20	20	20	20
10.7	Sound pressure level at the driver's seat	< 69.7	< 69.7	< 69.7	< 69.7

<sup>1</sup> With load backrest add 20" (MR14-MR16-MR16N MR16HD) add 17.44" (MR20-MR25-MR20HD).  
<sup>2</sup> With beacon add 4.73"; with OHG grid protector add 1.18"; with OHG screen protector add 1.77".  
<sup>3</sup> With load wheels lateral covers: 50.78" (MR14-MR16-MR20 MR16HD), 45.39" (MR16N), 54.06" (MR25-MR20HD).  
<sup>4</sup> Forks retracted.  
<sup>5</sup> See battery tables.  
<sup>6</sup> Values in brackets { } are optional.  
<sup>7</sup> Side shift stroke is +/-2.95" on all trucks. Reduced to +/-0.98" for MR16N.  
<sup>8</sup> These values may vary of +/- 5%.  
<sup>9</sup> For models MR14-16 with mast 4 stg: Add 2.09"  
<sup>10</sup> For models MR20-25 with mast 4 stg: Add 4.25"  
<sup>11</sup> For AST with mast 4 stg, Contact your local dealer or applications engineering add 17.44" (MR20-MR25-MR20HD).  
<sup>12</sup> For model MR16N with work lights on 35.4" wide carriage add 4.45"  
<sup>13</sup> With work lights on 43.3" wide carriage: for model MR16N add 12.32", for models MR14 - MR16 - MR20 - MR16HD add 6.81", for models MR25 - MR20HD add 3.66"  
<sup>14</sup> With PAL side line lights add 5.32"; With Double Work Light to Front add 8.66"  
<sup>15</sup> For model MR14 with mast lift height <= 216.5" and battery 420 Ah and Operator Shield Transparent (Lexan) / Wire Mesh Screen: Add 2.83" to 4.20, Subtract 2.83" from 1.8, Aisle Width 4.34.1 = 109.05", Aisle Width 4.34.2 = 111.38"  
<sup>16</sup> For model MR16 with mast lift height <= 216.5" and battery 420 Ah and Operator Shield Transparent (Lexan) / Wire Mesh Screen: Add 2.83" to 4.20, Subtract 2.83" from 1.8, Aisle width 4.34.1 = 109.5", Aisle Width 4.34.2 = 111.42"  
<sup>17</sup> Gradeability grades based on motor thermal capacity, torque available and brake requirements  
<sup>†</sup> NOTE: Performance specifications/ratings are for truck equipped as described under Standard Equipment in this Specification Sheet. Performance specifications are affected by the condition of the vehicle and how it is equipped, as well as by the nature and condition of the operating area. Specifications are subject to change and the proposed application should be discussed with your authorized Yale® dealer.  
<sup>††</sup> All values are nominal values and are subject to tolerances. For further information on this dimension, please contact your local Yale® dealer.  
 Above specifications, unless otherwise listed, are for a standard truck without optional equipment. Yale® products are subject to change without notice. Lift trucks illustrated may feature optional equipment.  
 Right Angle Stack (Aisle Width) - See truck dimensions for batteries chart.  
 RL = Rated Load, NL = No Load

GENERAL SPECIFICATIONS - MR20, MRHD, MR25							
GENERAL	1.1	Manufacturer (abbreviation)	Yale	Yale	Yale		
	1.2	Manufacturer's type designation	MR20	MR20HD	MR25		
	1.3	Drive: electric, diesel, gasoline, LPG	Electric (battery)	Electric (battery)	Electric (battery)		
	1.4	Operator type	Seated	Seated	Seated		
	1.5	Rated capacity/rated load	lb. (kg)	4500 (2000)	4500 (2000)	5500 (2500)	
	1.6	Load center distance	in. (mm)	24 (600)	24 (600)	24 (600)	
	1.8	Load distance, center of drive axle to fork <sup>9,10,15,16</sup>	in. (mm)	16.32 (415)	15.24 (387)	20.0 (508)	
	1.9	Wheelbase	in. (mm)	59.06 (1500)	61.02 (1550)	65.75 (1670)	
	WEIGHT	2.1	Service weight	lb. (kg)	7970 (3615)	9755 (4425)	8902 (4038)
2.3		Axle loading, NL front/rear <sup>4</sup>	lb. (kg)	4985/2985 (2261/1354)	5659/4096 (2567/1858)	5556/3347 (2520/1518)	
2.4		Axle loading fork advanced, RL front/rear	lb. (kg)	1479/10897 (671/4943)	1964/12200 (891/5534)	1704/12710 (773/5765)	
2.5		Axle loading fork retracted, RL front/rear	lb. (kg)	4480/7899 (2032/3583)	4927/9235 (2235/4189)	5227/9187 (2371/4167)	
3.1		Tires, front/rear		NDIltthane/NDIltthane	NDIltthane/NDIltthane	NDIltthane/NDIltthane	
3.2		Tire size, front	in. (mm)	13.5 x 5.5 (343 x 140)	13.5 x 5.5 (343 x 140)	13.5 x 5.5 (343 x 140)	
3.3		Tire size, rear	in. (mm)	11.2 x 3.9 (285 x 100)	13.8 x 4.3 (350 x 110)	13.8 x 5.5 (350 x 140)	
3.5		Wheels, number front/rear (x = driven wheels)		1x/2	1x/2	1x/2	
3.7		Tread, rear	in. (mm)	45.47 (1155)	45.39 (1153)	46.57 (1183)	
DIMENSIONS	4.1	Tilt of mast/fork carriage forward/backward	degrees	2/4	2/4	2/4	
	4.2	Height of mast, lowered	in. (mm)	See Mast Tables	See Mast Tables	See Mast Tables	
	4.3	Free lift	in. (mm)	See Mast Tables	See Mast Tables	See Mast Tables	
	4.4	Lift	in. (mm)	See Mast Tables	See Mast Tables	See Mast Tables	
	4.5	Height, mast extended <sup>1</sup>	in. (mm)	See Mast Tables	See Mast Tables	See Mast Tables	
	4.7	Height of overhead guard (cabin) <sup>2,14</sup>	in. (mm)	85.63 (2175)	85.63 (2175)	85.63 (2175)	
	4.8	Seat height relating to SIP	in. (mm)	42.60 (1082)	42.60 (1082)	42.60 (1082)	
	4.10	Height of wheel arms	in. (mm)	12.13 (308)	14.69 (373)	14.69 (373)	
	4.19	Overall length	in. (mm)	96.50 (2451)	99.53 (2528)	99.53 (2528)	
	4.20	Length to face of forks <sup>15,16</sup>	in. (mm)	51.79 (1316)	54.82 (1393)	54.82 (1393)	
	4.21	Overall width <sup>3,12,13</sup>	in. (mm)	49.80 (1265)	50.12 (1273)	52.95 (1345)	
	4.22	Fork dimensions DIN ISO 2331	in. (mm)	1.6/4.7/45.3 (40/120/1150)	1.8/4.7/45.3 (45/120/1150)	1.8/4.7/45.3 (45/120/1150)	
	4.23	Fork carriage ISO 2328, class/type A, B		2A	2A	2A	
	4.24	Fork carriage width	in. (mm)	27.56 (700)	27.56 (700)	27.56 (700)	
	4.25	Distance between fork arms, min/max <sup>7</sup>	in. (mm)	10.24/26.77 (260/680)	10.24/26.77 (260/680)	10.24/26.77 (260/680)	
	4.26	Distance between wheel arms/loading surfaces	in. (mm)	35.43 (900)	35.43 (900)	35.43 (900)	
	4.28	Reach distance	in. (mm)	24.13 (613)	21.10 (536)	29.06 (738)	
	4.31	Ground clearance, RL, below mast	in. (mm)	2.95 (75)	2.95 (75)	2.95 (75)	
	4.32	Ground clearance, center of wheelbase	in. (mm)	3.35 (85)	3.35 (85)	3.35 (85)	
	4.34.1	Aisle width for pallets 39.3"x47.2" (1000mm x 1200mm) across - (L6 x b12) <sup>11,15,16</sup>	in. (mm)	110.43 (2805) - See Charts	113.07 (2872) - See Charts	114.41 (2906) - See Charts	
	4.34.2	Aisle width for pallets 31.5"x47.2" (800mm x 1200mm) lengthwise - (b12 x L6) <sup>11,15,16</sup>	in. (mm)	112.13 (2848) - See Charts	115.0 (2921) - See Charts	115.31 (2929) - See Charts	
	4.35	Turning radius (Wa)	in. (mm)	69.57 (1767)	71.46 (1815)	75.98 (1930)	
	4.37	Length across wheel arms	in. (mm)	74.61 (1895)	77.87 (1978)	82.60 (2098)	
	4.42	Step height (from ground to running board)	in. (mm)	21.65 (550)	21.65 (550)	21.65 (550)	
	4.43	Step height (between intermediate steps between running board and floor)	in. (mm)	14.61 (371)	14.61 (371)	14.61 (371)	
	PERFORMANCE DATA	5.1	Travel speed, RL   NL <sup>6</sup>	mph (km/h)	8.7/8.7 (14/14)	8.7/8.7 (14/14)	8.7/8.7 (14/14)
		5.1.1	Travel speed, RL   NL, backwards <sup>6</sup>	mph (km/h)	8.7/8.7 (14/14)	8.7/8.7 (14/14)	8.7/8.7 (14/14)
5.2		Lift speed, RL   NL <sup>6</sup>	ft/min (m/s)	72.8/126 (0.37/0.64)	72.8/133.9 (0.37/0.68)	59.1/126 (0.30/0.64)	
5.3		Lowering speed, RL/NL	ft/min (m/s)	108.3/98.4 (0.55/0.50)	108.3 (0.55/0.55)	108.3/98.4 (0.55/0.50)	
5.4		Reaching speed, RL/NL	ft/min (m/s)	33.5/33.5 (0.17/0.17)	33.5/33.5 (0.17/0.17)	33.5/33.5 (0.17/0.17)	
5.7		Gradeability, RL/NL <sup>4,17</sup>	%	14/20	11/16	12/20	
5.8		Max. gradeability RL/NL <sup>17</sup>	%	14/20	11/16	12/20	
5.10		Service brake		Electric	Electric	Electric	
6.1		Drive motor, S2 60 minute rating	kW	9.6	9.6	9.6	
6.2		Lift motor, S3 15% rating	kW	14	14	14	
ELECTRIC	6.4	Battery voltage/nominal capacity	(V)/(Ah)	48/560 <sup>5</sup>	48/700 <sup>5</sup>	48/700 <sup>5</sup>	
	6.5	Battery weight <sup>8</sup>	lb. (kg)	2070 (939)	2467 (1119)	2467 (1119)	
	8.1	Type of drive unit		AC	AC	AC	
	10.1	Operating pressure for attachments	bar	180	180	180	
	10.2	Oil volume for attachment	l/min	20	20	20	
OTHER	10.7	Sound pressure level at the driver's seat	dB(A)	<69.7	<69.7	<69.7	

<sup>1</sup> With load backrest add 20" (MR14-MR16-MR16N-MR16HD) add 17.44" (MR20-MR25-MR20HD).

<sup>2</sup> With beacon add 4.73"; with DHG grid protector add 1.18"; with DHG screen protector add 1.77".

<sup>3</sup> With load wheels lateral covers: 50.78" (MR14-MR16-MR20-MR16HD), 45.39" (MR16N), 54.06" (MR25-MR20HD).

<sup>4</sup> Forks retracted.

<sup>5</sup> See battery tables.

<sup>6</sup> Values in brackets { } are optional.

<sup>7</sup> Side shift stroke is +/-2.95" on all trucks. Reduced to +/-0.98" for MR16N.

<sup>8</sup> These values may vary of +/- 5%.

<sup>9</sup> For models MR14-16 with mast 4 stg: Add 2.09"

<sup>10</sup> For models MR20-25 with mast 4 stg: Add 4.25"

<sup>11</sup> For AST with mast 4 stg, Contact your local dealer or applications engineering

<sup>12</sup> For model MR16N with work lights on 35.4" wide carriage add 4.45"

<sup>13</sup> With work lights on 43.3" wide carriage: for model MR16N add 12.32"; for models MR14 - MR16 - MR20 - MR16HD add 6.81"; for models MR25 - MR20HD add 3.66"

<sup>14</sup> With PAL side line lights add 5.32"; With Double Work Light to Front add 8.66"

<sup>15</sup> For model MR14 with mast lift height <= 216.5" and battery 420 Ah and Operator Shield Transparent (Lexan) / Wire Mesh Screen: Add 2.83" to 4.20, Subtract 2.83" from 1.8, Aisle Width 4.34.1 = 109.05", Aisle Width 4.34.2 = 111.38"

<sup>16</sup> For model MR16 with mast lift height <= 216.5 in and battery 420 Ah and Operator Shield Transparent (Lexan) / Wire Mesh Screen: Add 2.83" to 4.20, Subtract 2.83" from 1.8, Aisle width 4.34.1 = 109.5", Aisle Width 4.34.2 = 111.42"

<sup>17</sup> Gradeability grades based on motor thermal capacity, torque available and brake requirements

† NOTE: Performance specifications/ratings are for truck equipped as described under Standard Equipment in this Specification Sheet. Performance specifications are affected by the condition of the vehicle and how it is equipped, as well as by the nature and condition of the operating area. Specifications are subject to change and the proposed application should be discussed with your authorized Yale® dealer.

†† All values are nominal values and are subject to tolerances. For further information on this dimension, please contact your local Yale® dealer.

Above specifications, unless otherwise listed, are for a standard truck without optional equipment. Yale® products are subject to change without notice. Lift trucks illustrated may feature optional equipment. Right Angle Stack (Aisle Width) - See truck dimensions for batteries chart.

RL = Rated Load, NL = No Load

MR14, MR16, MR16N - MAST DETAILS, 3-STAGE FULL FREE LIFT (3000 / 3500 LBS.)					
Model	Lift (4.4)	Free Lift (4.3)	Height of Mast Lowered (4.2)	Height of Mast Extended w/o LBR (4.5) <sup>1</sup>	
	in. (mm)	in. (mm)	in. (mm)	in. (mm)	
MR14, MR16	196 (5000)	64 (1648)	87 (2195)	220 (5563)	
	206 (5250)	68 (1734)	90 (2281)	229 (5813)	
	216 (5500)	71 (1820)	94 (2367)	239 (6063)	
	226 (5750)	75 (1906)	97 (2453)	249 (6313)	
	236 (6000)	78 (1992)	100 (2539)	259 (6563)	
	246 (6250)	81 (2078)	104 (2625)	269 (6813)	
	255 (6500)	85 (2164)	107 (2711)	279 (7063)	
	265 (6750)	88 (2250)	111 (2797)	288 (7313)	
	275 (7000)	91 (2336)	114 (2883)	298 (7563)	
	285 (7250)	95 (2422)	117 (2969)	308 (7813)	
	295 (7500)	98 (2508)	121 (3055)	318 (8063)	
	305 (7750)	102 (2594)	124 (3141)	328 (8313)	
	314 (8000)	105 (2680)	128 (3227)	338 (8563)	
	324 (8250)	108 (2766)	131 (3313)	347 (8813)	
	334 (8500)	112 (2852)	134 (3399)	357 (9063)	
	344 (8750)	115 (2938)	138 (3485)	367 (9313)	
	354 (9000)	119 (3024)	141 (3571)	377 (9563)	
	364 (9250)	122 (3110)	144 (3657)	387 (9813)	
	374 (9500)	125 (3196)	148 (3753)	397 (10063)	
	383 (9750)	129 (3282)	152 (3839)	407 (10313)	
	393 (10000)	132 (3368)	155 (3925)	416 (10563)	
	403 (10250)	135 (3454)	158 (4011)	426 (10813)	
	413 (10500)	139 (3540)	162 (4097)	436 (11063)	
	423 (10750)	142 (3626)	165 (4183)	446 (11313)	
	MR20, MR25	183 (4650)	62 (1582)	87 (2195)	208 (5263)
		192 (4900)	65 (1668)	90 (2281)	218 (5513)
		202 (5150)	69 (1754)	94 (2367)	227 (5763)
212 (5400)		72 (1840)	97 (2453)	237 (6013)	
222 (5650)		75 (1926)	100 (2539)	247 (6263)	
232 (5900)		79 (2012)	104 (2625)	257 (6513)	
242 (6150)		82 (2098)	107 (2711)	267 (6763)	
251 (6400)		85 (2184)	111 (2797)	277 (7013)	
261 (6650)		89 (2270)	114 (2883)	286 (7263)	
271 (6900)		92 (2356)	117 (2969)	296 (7513)	
281 (7150)		96 (2442)	121 (3055)	306 (7763)	
291 (7400)		99 (2528)	124 (3141)	316 (8013)	
301 (7650)		102 (2614)	128 (3227)	326 (8263)	
311 (7900)		106 (2700)	131 (3313)	336 (8513)	
320 (8150)		109 (2786)	134 (3399)	345 (8763)	
330 (8400)		113 (2873)	138 (3485)	355 (9013)	
340 (8650)		116 (2959)	141 (3571)	365 (9263)	
350 (8900)		119 (3045)	144 (3657)	375 (9513)	
360 (9150)		123 (3131)	148 (3753)	385 (9763)	
370 (9400)		126 (3217)	152 (3839)	395 (10013)	
379 (9650)		130 (3303)	155 (3925)	405 (10263)	
389 (9900)		133 (3389)	158 (4011)	414 (10513)	
399 (10150)		136 (3475)	162 (4097)	424 (10763)	
409 (10400)		140 (3561)	165 (4183)	434 (11013)	
MR16HD		311 (7900)	105 (2680)	128 (3227)	334 (8463)
		320 (8150)	108 (2766)	131 (3313)	344 (8713)
		330 (8400)	112 (2852)	134 (3399)	353 (8963)
	340 (8650)	115 (2938)	138 (3485)	363 (9213)	
	350 (8900)	119 (3024)	141 (3571)	373 (9463)	
	360 (9150)	122 (3110)	144 (3657)	383 (9713)	
	370 (9400)	125 (3196)	148 (3753)	393 (9963)	
	379 (9650)	129 (3282)	152 (3839)	403 (10213)	
	389 (9900)	132 (3368)	155 (3925)	412 (10463)	
	399 (10150)	135 (3454)	158 (4011)	422 (10713)	
	409 (10400)	139 (3540)	162 (4097)	432 (10963)	
	419 (10650)	142 (3626)	165 (4183)	442 (11213)	
	429 (10900)	146 (3712)	169 (4269)	452 (11463)	
	438 (11150)	149 (3798)	172 (4355)	462 (11713)	
	448 (11400)	152 (3884)	175 (4441)	471 (11963)	

<sup>1</sup> With load backrest 39.37" height, add 20"; with load backrest 59.06" height, add 39.69".

<sup>2</sup> With load backrest 39.37" height, add 17.44"; with load backrest 59.06" height, add 37.12".

<sup>3</sup> With load backrest 39.37" height, add 20"; with load backrest 59.06" height, add 39.69".

**MR20HD - MAST DETAILS - HEAVY DUTY 3 STAGE FULL FREE LIFT (4500 LBS.)**

Model	Lift (4.4)	Free Lift (4.3)	Height of Mast Lowered (4.2)	Height of Mast Extended (4.5) <sup>1</sup>
	in. (mm)	in. (mm)	in. (mm)	in. (mm)
MR20HD	305 (7750)	102 (2614)	128 (3227)	330 (8363)
	314 (8000)	106 (2700)	131 (3313)	340 (8613)
	324 (8250)	109 (2786)	134 (3399)	349 (8863)
	334 (8500)	113 (2872)	138 (3485)	359 (9113)
	344 (8750)	116 (2958)	141 (3571)	369 (9363)
	354 (9000)	119 (3044)	144 (3657)	379 (9613)
	364 (9250)	123 (3130)	148 (3753)	389 (9863)
	374 (9500)	126 (3216)	152 (3839)	399 (10113)
	383 (9750)	130 (3302)	155 (3925)	408 (10363)
	393 (10000)	133 (3388)	158 (4011)	418 (10613)
	403 (10250)	136 (3474)	162 (4097)	428 (10863)
	413 (10500)	140 (3560)	165 (4183)	438 (11113)
	423 (10750)	143 (3646)	169 (4269)	448 (11363)
	433 (11000)	146 (3732)	172 (4355)	458 (11613)
	442 (11250)	150 (3818)	175 (4441)	468 (11863)
	452 (11500)	153 (3904)	179 (4527)	477 (12113)
	462 (11750)	157 (3990)	182 (4613)	487 (12363)
	472 (12000)	160 (4076)	185 (4699)	497 (12613)
	482 (12250)	163 (4162)	189 (4785)	507 (12863)
	492 (12500)	167 (4248)	192 (4871)	517 (13113)
	501 (12750)	170 (4334)	196 (4957)	527 (13373)
	511 (13000)	174 (4420)	199 (5043)	536 (13613)
	521 (13250)	177 (4506)	202 (5129)	546 (13863)
	531 (13500)	180 (4592)	206 (5215)	556 (14113)
	541 (13750)	184 (4678)	209 (5301)	566 (14363)
	551 (14000)	187 (4764)	213 (5387)	576 (14613)

<sup>1</sup> With load backrest 39.37" height, add 17.44"; with load backrest 59.06" height, add 37.12".

**MR14, MR16, MR16N - MAST DETAILS, 4-STAGE FULL FREE LIFT (3000 / 3500 LBS.)**

Model	Lift (4.4)	Free Lift (4.3)	Height of Mast Lowered (4.2)	Height of Mast Extended w/o LBR (4.5) <sup>2</sup>	
	in. (mm)	in. (mm)	in. (mm)	in. (mm)	
MR14, MR16	261 (6650)	66 (1700)	90 (2280)	285 (7230)	
	277 (7050)	70 (1800)	94 (2380)	301 (7630)	
	293 (7450)	74 (1900)	98 (2480)	317 (8030)	
	309 (7850)	78 (2000)	102 (2580)	332 (8430)	
	316 (8050)	80 (2050)	104 (2630)	340 (8630)	
	326 (8300)	84 (2150)	108 (2730)	350 (8880)	
	334 (8500)	86 (2200)	110 (2780)	358 (9080)	
	342 (8700)	88 (2250)	112 (2830)	366 (9280)	
	360 (9150)	94 (2400)	118 (2980)	384 (9730)	
	370 (9400)	98 (2500)	122 (3080)	393 (9980)	
	387 (9850)	104 (2650)	128 (3230)	411 (10430)	
	395 (10050)	106 (2700)	130 (3280)	419 (10630)	
	MR16N	261 (6650)	66 (1700)	90 (2280)	285 (7230)
		277 (7050)	70 (1800)	94 (2380)	301 (7630)

<sup>2</sup> With load backrest 39.37" height, add 20"; with load backrest 59.06" height, add 39.69". Note: 4-Stage Masts Void UL 'E' Certification

**MR20, MR25, MR20HD - MAST DETAILS, 4-STAGE FULL FREE LIFT (4500 / 5500 LBS.)**

Model	Lift (4.4)	Free Lift (4.3)	Height of Mast Lowered (4.2)	Height of Mast Extended w/o LBR (4.5) <sup>3</sup>
	in. (mm)	in. (mm)	in. (mm)	in. (mm)
MR20, MR25	277 (7050)	70 (1800)	94 (2380)	301 (7630)
	293 (7450)	74 (1900)	98 (2480)	317 (8030)
	309 (7850)	78 (2000)	102 (2580)	332 (8430)
	316 (8050)	80 (2050)	104 (2630)	340 (8630)
	326 (8300)	84 (2150)	108 (2730)	350 (8880)
	334 (8500)	86 (2200)	110 (2780)	358 (9080)
	342 (8700)	88 (2250)	112 (2830)	366 (9280)
	360 (9150)	94 (2400)	118 (2980)	384 (9730)
	370 (9400)	98 (2500)	122 (3080)	393 (9980)
	387 (9850)	104 (2650)	128 (3230)	411 (10430)
MR20HD	395 (10050)	106 (2700)	130 (3280)	419 (10630)
	405 (10300)	110 (2800)	134 (3380)	429 (10880)
	413 (10500)	112 (2850)	135 (3430)	437 (11080)
	423 (10750)	116 (2950)	139 (3530)	447 (11330)
	433 (11000)	120 (3050)	143 (3630)	456 (11580)
	448 (11400)	124 (3150)	147 (3730)	472 (11980)

<sup>3</sup> With load backrest 39.37" height, add 20"; with load backrest 59.06" height, add 39.69". Note: 4-Stage Masts Void UL 'E' Certification

**MR14 TRUCK DIMENSIONS FOR BATTERIES**

1.8	Load distance, center of drive axle to fork	in. (mm)	15.81 (402)	12.97 (330)	15.81 (402)	12.97 (330)	10.14 (258)	10.14 (258)
1.9	Wheelbase	in. (mm)	55.12 (1400)	55.12 (1400)	55.12 (1400)	55.12 (1400)	55.12 (1400)	55.12 (1400)
2.1	Service weight	lb. (kg)	6861 (3112)	7295 (3309)	6861 (3112)	7319 (3320)	7705 (3495)	7807 (3541)
2.3	Axle loading, NL front/rear <sup>5</sup>	lb. (kg)	4359/ 2502 (1977/1135)	4464/ 2833 (2025/1285)	4359/ 2502 (1977/1135)	4480/ 2842 (2032/1289)	*4530/ 3175 (2055/1440)*	4594/ 3212 (2084/1457)
2.4	Axle loading fork advanced, RL front/rear	lb. (kg)	1504/ 8444 (682/3830)	1746/ 8636 (792/3917)	1504/ 8444 (682/3830)	1764/ 8644 (800/3921)	*1951/ 8841 (885/4010)*	2015/ 8878 (914/4027)
2.5	Axle loading fork retracted, RL front/rear	lb. (kg)	3920/ 6030 (1778/2735)	3865/ 6517 (1753/2956)	3920/ 6030 (1778/2735)	3880/ 6526 (1760/2960)	*3772/ 7020 (1711/3184)*	3838/ 7057 (1741/3201)
4.19	Overall length	in. (mm)	93.64 (2379)	96.48 (2451)	93.64 (2379)	96.48 (2451)	99.31 (2523)	99.31 (2523)
4.20	Length to face of forks	in. (mm)	48.37 (1229)	51.20 (1301)	48.37 (1229)	51.20 (1301)	54.04 (1373)	54.04 (1373)
4.28	Reach distance	in. (mm)	23.03 (585)	20.20 (513)	23.03 (585)	20.20 (513)	17.36 (441)	17.36 (441)
4.34.1	Aisle width for pallets 39.3"x47.2" (1000mm x 1200mm) across - (L6 x b12) <sup>6</sup>	in. (mm)	107.01 (2718)	109.09 (2771)	107.01 (2718)	109.09 (2771)	111.34 (2828)	111.26 (2826)
4.34.2	Aisle width for pallets 31.5"x47.2" (800mm x 1200mm) lengthwise - (b12 x L6) <sup>6</sup>	in. (mm)	108.82 (2764)	111.38 (2829)	108.82 (2764)	111.38 (2829)	113.98 (2895)	113.98 (2895)
4.34.3	Aisle width for pallets 40" x 48" lengthwise (b12 x L6) <sup>6</sup>	in. (mm)	111.54 (2833)	113.97 (2895)	111.54 (2833)	113.97 (2895)	116.46 (2958)	116.46 (2958)
4.34.4	Aisle width for pallets 48" x 48" (b12 x L6) <sup>6</sup>	in. (mm)	113.82 (2891)	116.13 (2950)	113.82 (2891)	116.13 (2950)	118.49 (3010)	118.49 (3010)
4.34.5	Aisle width for pallets 48" x 40" across (b12 x L6) <sup>6</sup>	in. (mm)	107.74 (2737)	109.81 (2789)	107.74 (2737)	109.81 (2789)	111.97 (2844)	111.97 (2844)
4.35	Turning radius	in. (mm)	65.79 (1671)	65.79 (1671)	65.79 (1671)	65.79 (1671)	65.79 (1671)	65.79 (1671)
6.3	Battery according to DIN 43531/35/36 A,B,C, no (reference only)		C	C	C "Super"	C "Super"	C	C "Super"
6.4	Battery voltage/nominal capacity	V/Ah	48/420	48/560	48/465	48/620	48/700	48/775
6.5	Battery weight <sup>4</sup>	lb. (kg)	1653 (750)	2070 (939)	1653 (750)	2094 (950)	2467 (1119)	2568 (1165)

**MR16 TRUCK DIMENSIONS FOR BATTERIES**

1.8	Load distance, center of drive axle to fork	in. (mm)	17.78 (452)	14.94 (380)	17.78 (452)	14.94 (380)	12.11 (308)	12.11 (308)
1.9	Wheelbase	in. (mm)	57.09 (1450)	57.09 (1450)	57.09 (1450)	57.09 (1450)	57.09 (1450)	57.09 (1450)
2.1	Service weight	lb. (kg)	6971 (3162)	7408 (3360)	6971 (3162)	7432 (3371)	7818 (3546)	7919 (3592)
2.3	Axle loading, NL front/rear <sup>5</sup>	lb. (kg)	4449/2522 (2018/1144)	4561/2846 (2069/1291)	4449/2522 (2018/1144)	4579/2853 (2077/1294)	*4636/3181 (2103/1443)*	4702/3217 (2133/1459)
2.4	Axle loading fork advanced, RL front/rear	lb. (kg)	1325/9176 (601/4162)	1574/9361 (714/4246)	1325/9176 (601/4162)	1590/9370 (721/4250)	*1786/9559 (810/4336)*	1850/9595 (839/4352)
2.5	Axle loading fork retracted, RL front/rear	lb. (kg)	4085/6413 (1853/2909)	4023/6911 (1825/3135)	4085/6413 (1853/2909)	4039/6920 (1832/3139)	*3922/7423 (1779/3367)*	3988/7458 (1809/3383)
4.19	Overall length	in. (mm)	93.64 (2379)	96.48 (2451)	93.64 (2379)	96.48 (2451)	99.31 (2523)	99.31 (2523)
4.20	Length to face of forks	in. (mm)	48.37 (1229)	51.20 (1301)	48.37 (1229)	51.20 (1301)	54.04 (1373)	54.04 (1373)
4.28	Reach distance	in. (mm)	25.00 (635)	22.17 (563)	25.00 (635)	22.17 (563)	19.33 (491)	19.33 (491)
4.34.1	Aisle width for pallets 39.3"x47.2" (1000mm x 1200mm) across - (L6 x b12) <sup>6,7</sup>	in. (mm)	107.52 (2731)	109.49 (2781)	107.52 (2731)	109.49 (2781)	111.57 (2834)	111.57 (2834)
4.34.2	Aisle width for pallets 31.5"x47.2" (800mm x 1200mm) lengthwise - (b12 x L6) <sup>6,7</sup>	in. (mm)	108.94 (2767)	111.42 (2830)	108.94 (2767)	111.42 (2830)	114.02 (2896)	114.02 (2896)
4.34.3	Aisle width for pallets 40" x 48" lengthwise (b12 x L6) <sup>6,7</sup>	in. (mm)	111.73 (2838)	114.13 (2899)	111.73 (2838)	114.13 (2899)	116.58 (2961)	116.58 (2961)
4.34.4	Aisle width for pallets 48" x 48" (b12 x L6) <sup>6,7</sup>	in. (mm)	114.10 (2898)	116.37 (2956)	114.10 (2898)	116.37 (2956)	118.69 (3015)	118.69 (3015)
4.34.5	Aisle width for pallets 48" x 40" across (b12 x L6) <sup>6,7</sup>	in. (mm)	108.22 (2749)	110.21 (2799)	108.22 (2749)	110.21 (2799)	112.31 (2853)	112.31 (2853)
4.35	Turning radius	in. (mm)	67.64 (1718)	67.64 (1718)	67.64 (1718)	67.64 (1718)	67.64 (1718)	67.64 (1718)
6.3	Battery according to DIN 43531/35/36 A,B,C, no (reference only)		C	C	C "Super"	C "Super"	C	C "Super"
6.4	Battery voltage/nominal capacity	V/Ah	48/420	48/560	48/465	48/620	48/700	48/775
6.5	Battery weight <sup>4</sup>	lb. (kg)	1653 (750)	2070 (939)	1653 (750)	2094 (950)	2467 (1119)	2568 (1165)

<sup>4</sup> These values may vary of +/- 5%.

<sup>5</sup> Forks retracted.

<sup>6</sup> Contact your local dealer or applications engineering for AST dimensions with cold storage cab or 4-Stage Masts.

<sup>7</sup> Contact your local dealer for AST dimensions with wide and extra wide frame options.

All weights (2.1 to 2.5) are with lowest mast and standard forks.

RL = Rated Load, NL = No Load



MR16N TRUCK DIMENSIONS FOR BATTERIES								
1.8	Load distance, center of drive axle to fork	in. (mm)	15.02 (382)	11.48 (292)	15.02 (382)	11.48 (292)	7.93 (202)	7.93 (202)
1.9	Wheelbase	in. (mm)	57.09 (1450)	57.09 (1450)	57.09 (1450)	57.09 (1450)	57.09 (1450)	57.09 (1450)
2.1	Service weight	lb. (kg)	6859 (3111)	7295 (3309)	6867 (3115)	7313 (3317)	7712 (3498)	7747 (3514)
2.3	Axle loading, NL front/rear <sup>5</sup>	lb. (kg)	4237/2621 (1922/1189)	4292/3003 (1947/1362)	4242/2626 (1924/1191)	4303/3009 (1952/1365)	*4310/3402 (1955/1543)*	4332/3415 (1965/1549)
2.4	Axle loading fork advanced, RL front/rear	lb. (kg)	1254/9132 (569/4142)	1482/9341 (672/4237)	1261/9134 (572/4143)	1493/9348 (677/4240)	*1669/9570 (757/4341)*	1689/9583 (766/4347)
2.5	Axle loading fork retracted, RL front/rear	lb. (kg)	3704/6684 (1680/3032)	3541/7282 (1606/3303)	3708/6687 (1682/3033)	3552/7288 (1611/3306)	*3338/7901 (1514/3584)*	3360/7915 (1524/3590)
4.19	Overall length	in. (mm)	96.40 (2449)	99.94 (2539)	96.40 (2449)	99.94 (2539)	103.48 (2629)	103.48 (2629)
4.20	Length to face of forks	in. (mm)	51.12 (1299)	54.67 (1389)	51.12 (1299)	54.67 (1389)	58.21 (1479)	58.21 (1479)
4.28	Reach distance	in. (mm)	22.24 (565)	18.70 (475)	22.24 (565)	18.70 (475)	15.16 (385)	15.16 (385)
4.34.1	Aisle width for pallets 39.3"x47.2" (1000mm x 1200mm) across - (L6 x b12) <sup>6</sup>	in. (mm)	108.74 (2762)	111.34 (2828)	108.74 (2762)	111.34 (2828)	114.09 (2898)	114.13 (2899)
4.34.2	Aisle width for pallets 31.5"x47.2" (800mm x 1200mm) lengthwise - (b12 x L6) <sup>6</sup>	in. (mm)	110.67 (2811)	113.90 (2893)	110.67 (2811)	113.90 (2893)	117.17 (2976)	117.17 (2976)
4.34.3	Aisle width for pallets 40" x 48" lengthwise (b12 x L6) <sup>6</sup>	in. (mm)	113.35 (2879)	116.42 (2957)	113.35 (2879)	116.42 (2957)	119.56 (3037)	119.56 (3037)
4.34.4	Aisle width for pallets 48" x 48" (b12 x L6) <sup>6</sup>	in. (mm)	115.59 (2936)	118.50 (3010)	115.59 (2936)	118.50 (3010)	121.51 (3086)	121.51 (3086)
4.34.5	Aisle width for pallets 48" x 40" across (b12 x L6) <sup>6</sup>	in. (mm)	109.45 (2780)	112.08 (2847)	109.45 (2780)	112.08 (2847)	114.86 (2917)	114.86 (2917)
4.35	Turning radius	in. (mm)	66.93 (1700)	66.93 (1700)	66.93 (1700)	66.93 (1700)	66.93 (1700)	66.93 (1700)
6.3	Battery according to DIN 43531/35/36 A,B,C, no (reference only)		B	B	B "Super"	B "Super"	B	B "Super"
6.4	Battery voltage/nominal capacity	V/Ah	48/420	48/560	48/465	48/620	48/700	48/775
6.5	Battery weight <sup>4</sup>	lb. (kg)	1645 (746)	2066 (937)	1653 (750)	2083 (945)	2467 (1119)	2502 (1135)

MR20 TRUCK DIMENSIONS FOR BATTERIES								
1.8	Load distance, center of drive axle to fork	in. (mm)	16.32 (415)	16.32 (415)	13.48 (343)	13.48 (343)		
1.9	Wheelbase	in. (mm)	59.06 (1500)	59.06 (1500)	59.06 (1500)	59.06 (1500)		
2.1	Service weight	lb. (kg)	7970 (3615)	7994 (3626)	8380 (3801)	8481 (3847)		
2.3	Axle loading, NL front/rear <sup>5</sup>	lb. (kg)	4985/2985 (2261/1354)	5000/2994 (2268/1358)	5062/3316 (2296/1504)	5128/3351 (2326/1520)		
2.4	Axle loading fork advanced, RL front/rear	lb. (kg)	1479/10897 (671/4943)	1497/10906 (679/4947)	1698/11089 (770/5030)	1766/11125 (801/5046)		
2.5	Axle loading fork retracted, RL front/rear	lb. (kg)	4480/7899 (2032/3583)	4495/7906 (2039/3586)	4345/8442 (1971/3829)	4414/8477 (2002/3845)		
4.19	Overall length	in. (mm)	96.48 (2451)	96.48 (2451)	99.31 (2523)	99.31 (2523)		
4.20	Length to face of forks	in. (mm)	51.79 (1316)	51.79 (1316)	54.63 (1388)	54.63 (1388)		
4.28	Reach distance	in. (mm)	24.13 (613)	24.13 (613)	21.30 (541)	21.30 (541)		
4.34.1	Aisle width for pallets 39.3"x47.2" (1000mm x 1200mm) across - (L6 x b12) <sup>6,7</sup>	in. (mm)	110.43 (2805)	110.43 (2805)	112.48 (2857)	112.48 (2857)		
4.34.2	Aisle width for pallets 31.5"x47.2" (800mm x 1200mm) lengthwise - (b12 x L6) <sup>6,7</sup>	in. (mm)	112.13 (2848)	112.13 (2848)	114.69 (2913)	114.69 (2913)		
4.34.3	Aisle width for pallets 40" x 48" lengthwise (b12 x L6) <sup>6,7</sup>	in. (mm)	114.91 (2919)	114.91 (2919)	117.34 (2980)	117.34 (2980)		
4.34.4	Aisle width for pallets 48" x 48" (b12 x L6) <sup>6,7</sup>	in. (mm)	117.19 (2977)	117.19 (2977)	119.50 (3035)	119.50 (3035)		
4.34.5	Aisle width for pallets 48" x 40" across (b12 x L6) <sup>6,7</sup>	in. (mm)	111.16 (2823)	111.16 (2823)	113.21 (2876)	113.21 (2876)		
4.35	Turning radius	in. (mm)	69.57 (1767)	69.57 (1767)	69.57 (1767)	69.57 (1767)		
6.3	Battery according to DIN 43531/35/36 A,B,C, no (reference only)		C	C "Super"	C	C "Super"		
6.4	Battery voltage/nominal capacity	V/Ah	48/560	48/620	48/700	48/775		
6.5	Battery weight <sup>4</sup>	lb. (kg)	2070 (939)	2094 (950)	2467 (1119)	2568 (1165)		

<sup>4</sup> These values may vary of +/- 5%.

<sup>5</sup> Forks retracted.

<sup>6</sup> Contact your local dealer or applications engineering for AST dimensions with cold storage cab or 4-Stage Masts.

<sup>7</sup> Contact your local dealer for AST dimensions with wide and extra wide frame options.

All weights (2.1 to 2.5) are with lowest mast and standard forks.

RL = Rated Load, NL = No Load

MR25 TRUCK DIMENSIONS FOR BATTERIES								
1.8	Load distance, center of drive axle to fork	in. (mm)	20.0 (508)	20.0 (508)	17.17 (436)	17.17 (436)		
1.9	Wheelbase	in. (mm)	65.75 (1670)	65.75 (1670)	65.75 (1670)	65.75 (1670)		
2.1	Service weight	lb. (kg)	8902 (4038)	9004 (4084)	9326 (4230)	9462 (4292)		
2.3	Axle loading, NL front/rear <sup>5</sup>	lb. (kg)	5556/3347 (2520/1518)	5626/3377 (2552/1532)	5655/3671 (2565/1665)	5745/3717 (2606/1686)		
2.4	Axle loading fork advanced, RL front/rear	lb. (kg)	1704/12710 (773/5765)	1773/12743 (804/5780)	1931/12908 (876/5855)	2022/12952 (917/5875)		
2.5	Axle loading fork retracted, RL front/rear	lb. (kg)	5227/9187 (2371/4167)	5296/9220 (2402/4182)	5084/9753 (2306/4424)	5176/9797 (2348/4444)		
4.19	Overall length	in. (mm)	99.51 (2528)	99.51 (2528)	102.34 (2600)	102.34 (2600)		
4.20	Length to face of forks	in. (mm)	54.82 (1393)	54.82 (1393)	57.66 (1465)	57.66 (1465)		
4.28	Reach distance	in. (mm)	29.06 (738)	29.06 (738)	26.22 (666)	26.22 (666)		
4.34.1	Aisle width for pallets 39.3"x47.2" (1000mm x 1200mm) across - (L6 x b12) <sup>6</sup>	in. (mm)	114.41 (2906)	114.41 (2906)	116.26 (2953)	116.26 (2953)		
4.34.2	Aisle width for pallets 31.5"x47.2" (800mm x 1200mm) lengthwise - (b12 x L6) <sup>6</sup>	in. (mm)	115.31 (2929)	115.31 (2929)	117.80 (2992)	117.80 (2992)		
4.34.3	Aisle width for pallets 40" x 48" lengthwise (b12 x L6) <sup>6</sup>	in. (mm)	118.26 (3004)	118.26 (3004)	120.60 (3063)	120.60 (3063)		
4.34.4	Aisle width for pallets 48" x 48" (b12 x L6) <sup>6</sup>	in. (mm)	120.73 (3067)	120.73 (3067)	122.92 (3122)	122.92 (3122)		
4.34.5	Aisle width for pallets 48" x 40" across (b12 x L6) <sup>6</sup>	in. (mm)	115.10 (2924)	115.10 (2924)	116.98 (2972)	116.98 (2972)		
4.35	Turning radius	in. (mm)	75.98 (1930)	75.98 (1930)	75.98 (1930)	75.98 (1930)		
6.3	Battery according to DIN 43531/35/36 A,B,C, no (reference only)		C	C "Super"	C	C "Super"		
6.4	Battery voltage/nominal capacity	V/Ah	48/700	48/775	48/840	48/930		
6.5	Battery weight <sup>4</sup>	lb. (kg)	2467 (1119)	2568 (1165)	2879 (1306)	3016 (1368)		

MR16HD TRUCK DIMENSIONS FOR BATTERIES								
1.8	Load distance, center of drive axle to fork	in. (mm)	12.13 (308)	12.13 (308)	11.54 (293)	11.54 (293)		
1.9	Wheelbase	in. (mm)	57.09 (1450)	57.09 (1450)	57.09 (1450)	57.09 (1450)		
2.1	Service weight	lb. (kg)	8902 (4038)	8927 (4049)	9312 (4224)	9414 (4270)		
2.3	Axle loading, NL front/rear <sup>5</sup>	lb. (kg)	5329/3574 (2417/1621)	5344/3583 (2424/1625)	5353/3960 (2428/1796)	5417/3997 (2457/1813)		
2.4	Axle loading fork advanced, RL front/rear	lb. (kg)	1947/10483 (883/4755)	1964/10490 (891/4758)	2158/10681 (979/4845)	2224/10717 (1009/4861)		
2.5	Axle loading fork retracted, RL front/rear	lb. (kg)	4788/7641 (2172/3466)	4806/7648 (2180/3469)	4639/8201 (2104/3720)	4705/8236 (2134/3736)		
4.19	Overall length	in. (mm)	99.31 (2523)	99.31 (2523)	99.31 (2523)	99.31 (2523)		
4.20	Length to face of forks	in. (mm)	54.06 (1373)	54.06 (1373)	54.65 (1388)	54.65 (1388)		
4.28	Reach distance	in. (mm)	19.33 (491)	19.33 (491)	19.33 (491)	19.33 (491)		
4.34.1	Aisle width for pallets 39.3"x47.2" (1000mm x 1200mm) across - (L6 x b12) <sup>6,7</sup>	in. (mm)	111.57 (2834)	111.57 (2834)	112.02 (2845)	112.02 (2845)		
4.34.2	Aisle width for pallets 31.5"x47.2" (800mm x 1200mm) lengthwise - (b12 x L6) <sup>6,7</sup>	in. (mm)	114.02 (2896)	114.02 (2896)	114.54 (2909)	114.54 (2909)		
4.34.3	Aisle width for pallets 40" x 48" lengthwise (b12 x L6) <sup>6,7</sup>	in. (mm)	116.58 (2961)	116.58 (2961)	117.10 (2974)	117.10 (2974)		
4.34.4	Aisle width for pallets 48" x 48" (b12 x L6) <sup>6,7</sup>	in. (mm)	118.69 (3015)	118.69 (3015)	119.17 (3027)	119.17 (3027)		
4.34.5	Aisle width for pallets 48" x 40" across (b12 x L6) <sup>6,7</sup>	in. (mm)	112.31 (2853)	112.31 (2853)	112.74 (2864)	112.74 (2864)		
4.35	Turning radius	in. (mm)	67.64 (1718)	67.64 (1718)	67.64 (1718)	67.64 (1718)		
6.3	Battery according to DIN 43531/35/36 A,B,C, no (reference only)		C	C "Super"	C	C "Super"		
6.4	Battery voltage/nominal capacity	V/Ah	48/560	48/620	48/700	48/775		
6.5	Battery weight <sup>4</sup>	lb. (kg)	2070 (939)	2094 (950)	2467 (1119)	2568 (1165)		

<sup>4</sup> These values may vary of +/- 5%.

<sup>5</sup> Forks retracted.

<sup>6</sup> Contact your local dealer or applications engineering for AST dimensions with cold storage cab or 4-Stage Masts.

<sup>7</sup> Contact your local dealer for AST dimensions with wide and extra wide frame options.

All weights (2.1 to 2.5) are with lowest mast and standard forks.

RL = Rated Load, NL = No Load

### MR20HD TRUCK DIMENSIONS FOR BATTERIES

		in (mm)	15.24 (387)	15.24 (387)	12.40 (315)	12.40 (315)
1.8	Load distance, center of drive axle to fork	in (mm)	15.24 (387)	15.24 (387)	12.40 (315)	12.40 (315)
1.9	Wheelbase	in (mm)	61.02 (1550)	61.02 (1550)	61.02 (1550)	61.02 (1550)
2.1	Service weight	lb (kg)	9755 (4425)	9857 (4471)	10179 (4617)	10315 (4679)
2.3	Axle loading, NL front/rear <sup>5</sup>	lb (kg)	5659/4096 (2567/1858)	5725/4131 (2597/1874)	5681/4497 (2577/2040)	5767/4548 (2616/2063)
2.4	Axle loading fork advanced, RL front/rear	lb (kg)	1964/12200 (891/5534)	2030/12236 (921/5550)	2172/12416 (985/5632)	2258/12467 (1024/5655)
2.5	Axle loading fork retracted, RL front/rear	lb (kg)	4927/9235 (2235/4189)	4996/9270 (2266/4205)	4738/9850 (2149/4468)	4826/9899 (2189/4490)
4.19	Overall length	in (mm)	99.51 (2528)	99.51 (2528)	102.34 (2600)	102.34 (2600)
4.20	Length to face of forks	in (mm)	54.82 (1393)	54.82 (1393)	57.66 (1465)	57.66 (1465)
4.28	Reach distance	in (mm)	21.10 (536)	21.10 (536)	18.27 (464)	18.27 (464)
4.34.1	Aisle width for pallets 39.3"x47.2" (1000mm x 1200mm) across - (L6 x b12) <sup>6</sup>	in (mm)	113.07 (2872)	113.07 (2872)	115.20 (2926)	115.20 (2926)
4.34.2	Aisle width for pallets 31.5"x47.2" (800mm x 1200mm) lengthwise - (b12 x L6) <sup>6</sup>	in (mm)	115.0 (2921)	115.0 (2921)	117.56 (2986)	117.56 (2986)
4.34.3	Aisle width for pallets 40" x 48" lengthwise (b12 x L6) <sup>6</sup>	in (mm)	117.72 (2990)	117.72 (2990)	120.17 (3052)	120.17 (3052)
4.34.4	Aisle width for pallets 48" x 48" (b12 x L6) <sup>6</sup>	in (mm)	119.94 (3046)	119.94 (3046)	122.27 (3106)	122.27 (3106)
4.34.5	Aisle width for pallets 48" x 40" across (b12 x L6) <sup>6</sup>	in (mm)	113.82 (2891)	113.82 (2891)	115.91 (2944)	115.91 (2944)
4.35	Turning radius	in (mm)	71.46 (1815)	71.46 (1815)	71.46 (1815)	71.46 (1815)
6.3	Battery according to DIN 43531/35/36 A,B,C, no (reference only)		C	C "Super"	C	C "Super"
6.4	Battery voltage/nominal capacity	V/Ah	48/700	48/775	48/840	48/930
6.5	Battery weight <sup>4</sup>	lb (kg)	2467 (1119)	2568 (1165)	2879 (1306)	3016 (1368)

<sup>4</sup> These values may vary of +/- 5%.

<sup>5</sup> Forks retracted.

<sup>6</sup> Contact your local dealer or applications engineering for AST dimensions with cold storage cab or 4-Stage Masts.

All weights (2.1 to 2.5) are with lowest mast and standard forks.

RL = Rated Load, NL = No Load

### TRUCK DIMENSIONS FOR BATTERIES - MR14, MR16, MR16N, MR20, MR25, MR16HD, MR20HD

TRUCK MODEL	Compartment Dimensions-Max.			Battery Dimensions-Max.			Volts	No. of Cells	Amp Hr Capacity Range	Weight	
	Width	Length	Height	X	Y	Z				Min	Max
	in (mm)	in (mm)	in (mm)	in (mm)	in (mm)	in (mm)				lb (kg)	lb (kg)
				+0"/-0.12" (+0/-3)	+0"/-0.12" (+0/-3)	+0"/-0.08" (+0/-2)					
MR14 - 3,000lb	48.15 (1223)	11.26 (286)	30.94 (786)	48.11 (1222)	11.14 (283)	30.87 (784)	48	24	420-465	1572 (713)	1737 (788)
MR14 - 3,000lb	48.15 (1223)	14.09 (358)	30.94 (786)	48.11 (1222)	13.98 (355)	30.87 (784)	48	24	560-620	1967 (892)	2200 (998)
MR14 - 3,000lb	48.15 (1223)	16.93 (430)	30.94 (786)	48.11 (1222)	16.81 (427)	30.87 (784)	48	24	700-775	2344 (1063)	2696 (1223)
MR16 - 3,500lb	48.15 (1223)	11.26 (286)	30.94 (786)	48.11 (1222)	11.14 (283)	30.87 (784)	48	24	420-465	1572 (713)	1737 (788)
MR16 - 3,500lb	48.15 (1223)	14.09 (358)	30.94 (786)	48.11 (1222)	13.98 (355)	30.87 (784)	48	24	560-620	1967 (892)	2200 (998)
MR16 - 3,500lb	48.15 (1223)	16.93 (430)	30.94 (786)	48.11 (1222)	16.81 (427)	30.87 (784)	48	24	700-775	2344 (1063)	2696 (1223)
MR16N - 3,500lb	40.75 (1035)	14.09 (358)	30.94 (786)	40.71 (1034)	13.90 (353)	30.87 (784)	48	24	420-465	1563 (709)	1737 (788)
MR16N - 3,500lb	40.75 (1035)	17.56 (446)	30.94 (786)	40.71 (1034)	17.44 (443)	30.87 (784)	48	24	560-620	1962 (890)	2187 (992)
MR16N - 3,500lb	40.75 (1035)	21.10 (536)	30.94 (786)	40.71 (1034)	20.98 (533)	30.87 (784)	48	24	700-775	2344 (1063)	2628 (1192)
MR20 - 4,500lb	48.15 (1223)	14.09 (358)	30.94 (786)	48.11 (1222)	13.98 (355)	30.87 (784)	48	24	560-620	1967 (892)	2200 (998)
MR20 - 4,500lb	48.15 (1223)	16.93 (430)	30.94 (786)	48.11 (1222)	16.81 (427)	30.87 (784)	48	24	700-775	2344 (1063)	2696 (1223)
MR25 - 5,500lb	48.15 (1223)	16.93 (430)	30.94 (786)	48.11 (1222)	16.81 (427)	30.87 (784)	48	24	700-775	2344 (1063)	2696 (1223)
MR25 - 5,500lb	48.15 (1223)	19.76 (502)	30.94 (786)	48.11 (1222)	19.65 (499)	30.87 (784)	48	24	840-930	2736 (1241)	3166 (1436)
MR16HD - 3,500lb	48.15 (1223)	14.09 (358)	30.94 (786)	48.11 (1222)	13.98 (355)	30.87 (784)	48	24	560-620	1967 (892)	2200 (998)
MR16HD - 3,500lb	48.15 (1223)	16.93 (430)	30.94 (786)	48.11 (1222)	16.81 (427)	30.87 (784)	48	24	700-775	2344 (1063)	2696 (1223)
MR20HD - 4,500lb	48.15 (1223)	16.93 (430)	30.94 (786)	48.11 (1222)	16.81 (427)	30.87 (784)	48	24	700-775	2344 (1063)	2696 (1223)
MR20HD - 4,500lb	48.15 (1223)	19.76 (502)	30.94 (786)	48.11 (1222)	19.65 (499)	30.87 (784)	48	24	840-930	2736 (1241)	3166 (1436)
MR2.0HD - 4,500lb	46.97 (1193)	19.37 (492)	30.94 (786)	46.85 (1190)	19.22 (488)	30.56 (776)	48	24	980-1085	2866 (1300)	3452 (1566)

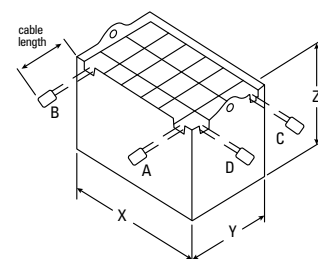

Battery compartment length is measured from front to rear.  
 Battery compartment width is measured across the truck.  
 Battery connector: 350 amp/48 volt (SB350 blue)  
 Battery lead: length 31.5" (800 mm) "A" position.  
 Battery cover - not needed

### FEATURES LIST - MR14, MR16, MR16N, MR20, MR25, MR16HD, MR20HD

PERFORMANCE	STD	OPT	OPERATION	STD	OPT
6.8mph Travel speed (MR14,MR16,MR16N)	•		180 Degree steering	•	
8.7mph Travel speed (MR20,MR25,MR16HD, MR20HD)	•		Keyless access		•
Lift performance package (MR20,MR25,MR16HD,MR20HD)	•		360 Degree steering		•
8.7mph Travel speed (MR14,MR16,MR16N)		•	Driver select steering mode 180/360 degree steering (push button)		•
Lift performance package (MR14,MR16,MR16N)		•	5th Hydraulic function		•
Laser line fork positioning aid (above free lift)		•	Universal support bracket		•
Auto sideshift centering		•	RF Terminal mount		•
Auto fork leveling in the horizontal position		•	Beverage holder and document tray		•
Height pre-selector (with/without pallet detection device)		•	Clipboard		•
Load backrest mounted color camera		•	Stretch film roll holder		•
Fork camera		•	Polycarbonate (lexan) protection on overhead guard		•
Inner mast camera and monitor		•	Metal grid protection on overhead guard (with or without cab)		•
Load weight Indicator		•	Full view overhead guard top		•
<b>DRIVE</b>	<b>STD</b>	<b>OPT</b>	High temperature environment		•
Park brake (spring applied, electrically released)	•		Side battery change - battery tray rollers		•
Top/front load wheel protection	•		Drive in rack overhead guard		•
Side load wheel protection		•	Side guide rollers		•
Various load wheels compounds		•	DC/DC Converter (12V/48V, 24V/48V, or 12-24V/48V)		•
Various drive tire compounds		•	Audible alarm (choice of forks leading, forks trailing, both travel directions)		•
<b>LIFT</b>	<b>STD</b>	<b>OPT</b>	Load backrest (39.4" (1000mm) / 59" (1500mm))		•
3 Stage mast/tilting carriage	•		Cold storage (-22 deg F (-30 deg C))		•
4 Stage mast / tilting carriage		•	Integrated cold storage cab (standard and drive in rack options)		•
Lift limit with override (1x or 2x height setting)		•	Cab intercom		•
Lower limit (with override option)		•	Drip rail (cold storage)		•
Telescoping forks		•	Pedestrian awareness lights (spotlight chassis direction - forks trailing)		•
Side shifting fork positioner		•	Pedestrian awareness lights (side line lights)		•
<b>HANDLING</b>	<b>STD</b>	<b>OPT</b>	Yale Vision		•
Touch point mini-levers hydraulic controls	•				
Speed slow down mast reached forward	•				
Speed slow down on cornering	•				
Speed slow down over free lift	•				
Simultaneous lift / reach functionality	•				
Joystick controls hydraulic controls		•			
Simultaneous hydraulic functions - 3 functions		•			
Lift comfort package		•			
<b>ERGONOMICS</b>	<b>STD</b>	<b>OPT</b>			
Intermediate step	•				
Grab handle on overhead guard and under armrest	•				
Adjustable length armrest	•				
Full suspension seat (2 in suspension travel)	•				
Standard display	•				
Adjustable steering column	•				
Premium touch screen display		•			
Full suspension seat (3 in suspension travel)		•			
Headrest		•			
Synchronized seat cushion and backrest movement		•			
Heated seat		•			
Anti-static seat		•			
Vinyl seat upholstery		•			
Flashing beacon		•			
Work lights x2 (mast side)		•			
Work lights x2 (driver side)		•			
Carriage mounted work lights		•			

# About Yale



Yale Lift Truck Technologies leverages over a century of material handling experience and substantial investment in innovation to bring the most advanced technology-driven lift truck solutions to market. The company offers a full line of award-winning lift trucks, including reach trucks, order pickers, turret trucks, pallet jacks and trucks, pallet stackers, tow tractors and counterbalanced forklifts, as well as powerful operator assist solutions, proven robotics and a wide range of power sources to help customers adapt to today's demanding supply chain. Yale and its independent dealer network support these solutions with comprehensive after-sales service, parts, financing and training.

## MATERIALS HANDLING FOR:

Third-party logistics (3PL)

Auto parts distribution

Beverage

Cold & frozen foods

Food distribution

Food processing

Furniture & furnishings

Government

Health & pharma

Home centers & durables

Retail & e-commerce

Yale Lift Truck Technologies  
P.O. Box 7367  
Greenville, NC 27835-7367  
U.S.A.

**yale.com**



EXPLORE MORE  
ONLINE.  
←

© 2023 Hyster-Yale Group, Inc., all rights reserved. YALE and  are trademarks of Hyster-Yale Group, Inc.

Trucks may be shown with optional equipment and/or features not available in all regions. Truck performance may be affected by the condition of the vehicle, how it is equipped and the application. Specifications are subject to change without notice. Consult your Yale® Dealer if any of the information shown is critical to your application.

CERTIFICATION: Yale lift trucks meet the design and construction requirements of B56.1-1969, per OSHA Section 1910.178(a)(2), and also comply with the B56.1 revision in effect at time of manufacture. Classified by Underwriters' Laboratories, Inc.