



NTA 030-035SB

SPEC SHEET

Very narrow aisle
turret truck

3,000-3,500 lbs.

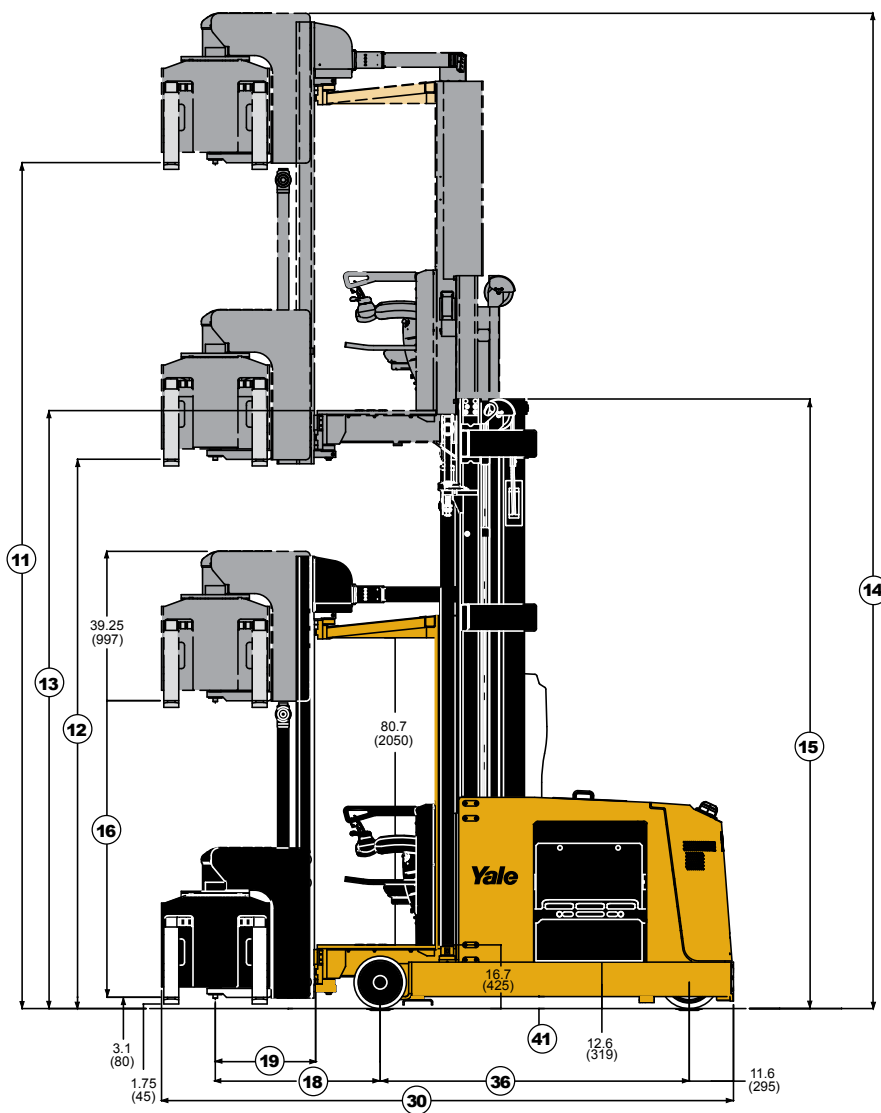
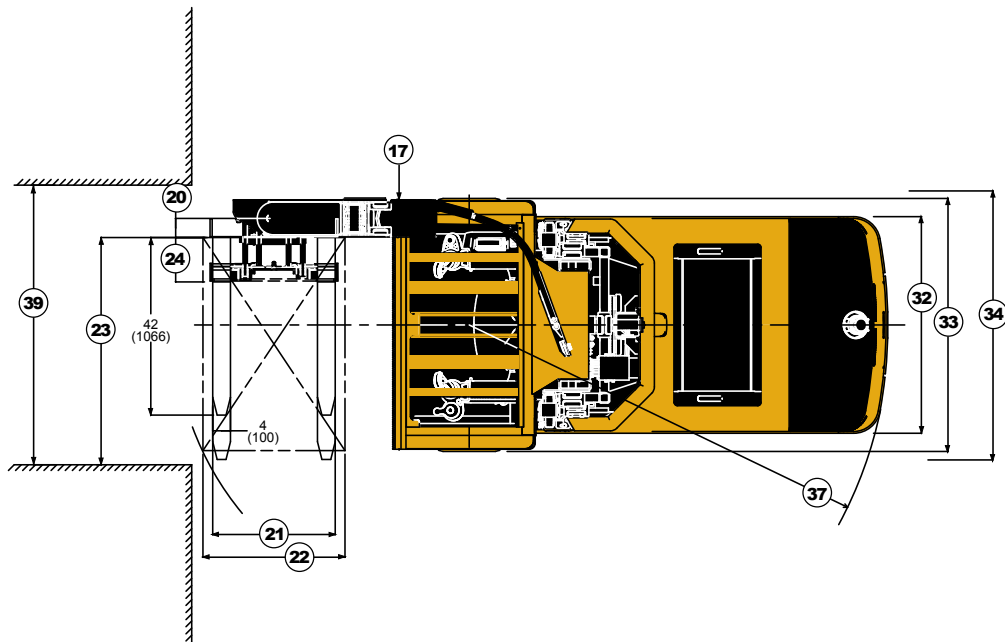

GENERAL SPECIFICATIONS - NTA030SB

				Yale			
				NTA030SB			
GENERAL	1	Manufacturer		Yale			
	2	Model designation		NTA030SB			
	3	Operation		Man-up turret - sit or stand operation			
	4	Wheelbase		Medium wheelbase	Long wheelbase		
	5	Rated capacity	lb. (kg)	3000 (1360)	3000 (1360)		
	6	Load center	in. (mm)	24 (610)	24 (610)		
	7	Drive power type: electric		Electric - 48 volt	Electric - 48 volt		
	8	Tire type: cushion, pneumatic	Load/drive	Cushion	Cushion		
	10	Mast type		Triform	Triform		
	DIMENSIONS	11	Mast, max. lift height, both masts (top of forks)		in. (mm)	See chart	See chart
12		Mast, max. lift height, main mast (top of forks)		in. (mm)	See chart	See chart	
13		Mast, maximum height, raised operator platform		in. (mm)	See chart	See chart	
14		Mast, maximum overall extended height		in. (mm)	See chart	See chart	
15		Mast, overall lower height		in. (mm)	See chart	See chart	
16		Auxiliary mast lift height (top of forks)		in. (mm)	See chart	See chart	
17		Traverse frame widths		in. (mm)	47.2/55.1/61/66.9 (1200/1400/1550/1700)	47.2/55.1/61/66.9 (1200/1400/1550/1700)	
18		Distance, rotator C/L to load wheel C/L	2-stg/3-stg	in. (mm)	43.3/46.3 (1101/1177)	43.3/46.3 (1101/1177)	
19		Pivot boom length		in. (mm)	26.4 (670)	26.4 (670)	
20		Pivot boom thickness		in. (mm)	8.3 (210)	8.3 (210)	
21		Fork carriage width		in. (mm)	28.3 (720)	28.3 (720)	
22		Fork spread adjustment (outside-outside dimension)	min/max	in. (mm)	20/28.3 (508/720)	20/28.3 (508/720)	
23		Traverse stroke		in. (mm)	40/46.8/52.7/57.7 (990/1190/1340/1490)	40/46.8/52.7/57.7 (990/1190/1340/1490)	
24		Reach carriage stroke (pantograph)		in. (mm)	4/5/6/8/10 (102/127/152/203/254)	4/5/6/8/10 (102/127/152/203/254)	
25		Cab width		in. (mm)	47.2/55.1/61/66.9 (1200/1400/1550/1700)	47.2/55.1/61/66.9 (1200/1400/1550/1700)	
26		Cab depth (front of cab to operator seat back)		in. (mm)	34.2 (870)	34.2 (870)	
27		Fork thickness x width x length	std. forks	in. (mm)	1.75 x 4 x 42 (45 x 100 x 1066)	1.75 x 4 x 42 (45 x 100 x 1066)	
28		Fork type			Pin	Pin	
29		Headlength (chassis length to face of traverse frame)	2-stg/3-stg	in. (mm)	105/108 (2669/2745)	109.8/112.8 (2789/2865)	
30		Overall truck length with tucked forks NL		2-stg/3-stg	in. (mm)	145.6/148.6 (3698/3774)	150.3/153.3 (3818/3894)
31		Length to face of forks (forks forward)		2-stg/3-stg	in. (mm)	135.6/138.6 (3444/3520)	140.3/143.3 (3564/3640)
32		Frame width		in. (mm)	48 (1220)	48 (1220)	
33		Base width (width across load wheels)		in. (mm)	48/56/62/68 (1220/1425/1575/1725)	48/56/62/68 (1220/1425/1575/1725)	
34		Width across guide rollers		in. (mm)	50.2/58/64/69.9 (1275/1475/1625/1775)	50.2/58/64/69.9 (1275/1475/1625/1775)	
35		Top of fork - mast lowered		in. (mm)	3.1 (80)	3.1 (80)	
36		Wheelbase		in. (mm)	76.5 (1943)	81.2 (2063)	
37		Minimum turning radius		in. (mm)	88.5 (2250)	93.3 (2370)	
38		Minimum transfer aisle with tucked load	2-stg/3-stg	in. (mm)	Contact sales	Contact sales	
39		Aisle width with pallet on forks	2-stg/3-stg	in. (mm)	Contact sales	Contact sales	
40		Ground clearance NL		in. (mm)	(45)	1.75 (45)	
41		Ground clearance center of wheelbase NL		in. (mm)	(75)	2.9 (75)	
WT.		42	Total approx. truck weight (with battery)		lb. (kg)	14740 (6701)	15475 (7034)
	43	Axle out, static w/rated load and standard mast	Load/drive	lb. (kg)	12922/4679 (5874/2127)	13332/5002 (6060/2274)	
PERFORMANCE	44	Travel speed RL/NL		mph	6.5/6.5	6.5/6.5	
	45	Lift speed, main mast RL/NL		fpm	65/83	65/83	
	46	Lift speed, auxiliary mast RL/NL		fpm	69/77	69/77	
	47	Lower speed, main mast RL/NL		fpm	98/98	98/98	
	48	Lower speed, auxiliary mast RL/NL		fpm	79/77	79/77	
	49	Attachment traverse speed RL/NL		in. per sec	7.5/7.9	7.5/7.9	
	50	Attachment rotate speed (full 180 deg. rotation)	max speed	sec	6	6	
	51	Maximum gradeability with RL		%	6	6	
BRAKES	52	Service brakes			Electric/mechanical	Electric/mechanical	
	53	Brake method of operation			Plugging	Plugging	
	54	Tire type	Load/drive		Polyurethane	Polyurethane	
WHEELS	55	Number of wheels: front/rear (x=drive)		Load/drive	2/1x	2/1x	
	56	Load wheel size	Load	in. (mm)	13.78 x 5.5 (350 x 140)	13.78 x 5.5 (350 x 140)	
	57	Drive wheel size	Drive	in. (mm)	15.75 x 6.3 (400 x 160)	16 x 7 (406 x 178)	
ELECTRIC	58	Battery		Type	Lead acid Thin Plate Pure Lead* Lithium-ion*	Lead acid Thin Plate Pure Lead* Lithium-ion*	
	59	Battery volts/max ampere hrs.		V/AH	48/1085	48/1240	
	60	Battery weight, minimum		lb. (kg)	2,976 (1350)	3,087 (1400)	
	61	Battery connector style on truck			Blue SB 350	Blue SB 350	
	62	Recommended battery lead length and connector position			30" position B	30" position B	
	63	Battery sizes (with optional spacer groups)	L/W	in.	44.2 x 20.8	38.7 x 23.6	
	64			in.	38.7 x 23.8	38.4 x 26.8	
	65			in.	-	38.7 x 27	
	66	Drive motor rating	60 min. rating	kw	7.5	7.5	
	67	Hoist motor rating (25% duty cycle rating)		kw	2 x 12	2 x 12	
	68	Drive motor control			AC - MOSFET	AC - MOSFET	
	69	Hoist motor control			AC - MOSFET	AC - MOSFET	

RL = rated load, NL = no load

*Optional with Yale Power Key

GENERAL SPECIFICATIONS - NTA035SB

GENERAL	1	Manufacturer		Yale		
	2	Model designation		NTA035SB		
	3	Operation		Man-up turret - sit or stand operation		
	4	Wheelbase		Short wheelbase	Medium wheelbase	Long wheelbase
	5	Rated capacity	lb. (kg)	3500 (1590)		
	6	Load center	in. (mm)	24 (610)		
	7	Drive power type: electric		Electric - 72 volt		
	8	Tire type: cushion, pneumatic	Load/drive	Cushion		
	10	Mast type		Triform	Quadform	Quadform
	DIMENSIONS	11	Mast, max. lift height, both masts (top of forks)		in. (mm) See chart	
12		Mast, max. lift height, main mast (top of forks)		in. (mm) See chart		
13		Mast, maximum height, raised operator platform		in. (mm) See chart		
14		Mast, maximum overall extended height		in. (mm) See chart		
15		Mast, overall lower height		in. (mm) See chart		
16		Auxiliary mast lift height (top of forks)		in. (mm) See chart		
17		Traverse frame widths		in. (mm) 47.2/55.1/61/66.9 (1200/1400/1550/1700)		
18		Distance, rotator C/L to load wheel C/L	2-Stg/3-stg	in. (mm) 43.3/46.3 (1101/1177)	43.3/49.3 (1101/1251)	43.3/49.3 (1101/1251)
19		Pivot boom length		in. (mm) 26.4 (670)		
20		Pivot boom thickness		in. (mm) 8.3 (210)		
21		Fork carriage width		in. (mm) 28.3 (720)		
22		Fork spread adjustment (outside-outside dimension)	Min/max	in. (mm) 20/28.3 (508/720)		
23		Traverse stroke		in. (mm) 40/46.8/52.7/57.7 (990/1190/1340/1490)		
24		Reach carriage stroke (pantograph)		in. (mm) 4/5/6/8/10 (102/127/152/203/254) 4/5/6/8/10 (102/127/152/203/254) 4/5/6/8/10 (102/127/152/203/254)		
25		Cab width		in. (mm) 47.2/55.1/61/66.9 (1200/1400/1550/1700)		
26		Cab depth (front of cab to operator seat back)		in. (mm) 34.2 (870)		
27		Fork thickness x width x length	Std. forks	in. (mm) 1.75 x 4 x 42 (45 x 100 x 1066)		
28		Fork type		Pin		
29		Headlength (chassis length to face of traverse frame)	2-Stg/3-stg	in. (mm) 109.8/112.8 (2789/2865)	114.9/120.8 (2919/3069)	122.6/128.5 (3114/3264)
30		Overall truck length with tucked forks NL	2-Stg/3-stg	in. (mm) 150.3/153.3 (3818/3894)	155.4/161.3 (3948/4098)	163.1/168 (4143/4293)
31		Length to face of forks (forks forward)	2-Stg/3-stg	in. (mm) 140.3/143.3 (3564/3640)	144.6/150.6 (3674/3824)	153.1/159.0 (3889/4039)
32		Frame width		in. (mm) 48 (1220)		
33		Base width (width across load wheels)		in. (mm) 48/56/62/68 (1220/1425/1575/1725)		
34		Width across guide rollers		in. (mm) 50.2/58/64/69.9 (1275/1475/1625/1775)		
35		Top of fork - mast lowered		in. (mm) 3.1 (80)		
36		Wheelbase		in. (mm) 81.2 (2063)	86.3 (2193)	94 (2388)
37		Minimum turning radius		in. (mm) 93.3 (2370)	98.2 (2495)	105.7 (2685)
38		Minimum transfer aisle with tucked load	2-Stg/3-stg	in. (mm) Contact sales		
39		Aisle width with pallet on forks	2-Stg/3-stg	in. (mm) Contact sales		
40		Ground clearance NL		in. (mm) 1.75 (45)		
41		Ground clearance center of wheelbase NL		in. (mm) 2.9 (75)		
WT.	42	Total approx. truck weight (with battery)		lb. (kg) 15744 (7170)	16907 (7685)	17426 (7921)
	43	Axle out, static w/rated load and standard mast	Load/drive	lb. (kg) 13913/5161 (6324/2346)	14491/5716 (6587/2598)	14738/5988 (6699/2722)
PERFORMANCE	44	Travel speed RL/NL		mph 6.5/6.5		
	45	Lift speed, main mast RL/NL		fpm 69/79		
	46	Lift speed, auxiliary mast RL/NL		fpm 69/77		
	47	Lower speed, main mast RL/NL		fpm 118/118		
	48	Lower speed, auxiliary mast RL/NL		fpm 79/77		
	49	Attachment traverse speed RL/NL		in. per sec 7.5/7.9		
	50	Attachment rotate speed (full 180 deg. rotation)	Max speed	sec 6		
	51	Maximum gradeability with RL		% 6		
ELECTRIC	52	Service brakes		Electric/mechanical		
	53	Brake method of operation		Plugging		
	WHEELS	54	Tire type	Load/drive	Polyurethane	
55		Number of wheels: front/rear (x=drive)	Load/drive	2/1x	2/1x	2/1x
56		Load wheel size	Load	in. (mm) 13.78 x 5.5 (350 x 140)		
57		Drive wheel size	Drive	in. (mm) 16 x 7 (406 x 178)		
ELECTRIC	58	Battery type		Lead acid Thin Plate Pure Lead* Lithium-ion*		
	59	Battery volts/max ampere hrs.	V/AH	72/775	72/930	72/1240
	60	Battery weight, minimum	lb. (kg)	3,307 (1500)	4,079 (1850)	4,189 (1900)
	61	Battery connector style on truck		Green SB 350		
	62	Recommended battery lead length and connector position		30" position B		
	63	Battery sizes (with optional spacer groups)	L/W	in. 38.3 x 13.5 (2x - 36V battery)	38.1 x 15.8 (2x - 36V battery)	38.3 x 17.9 (2x - 36V battery)
	64			in. 37.9 x 14.0 (2x - 36V battery)	37.9 x 15.5 (2x - 36V battery)	38.7 x 20.4 (2x - 36V battery)
	65			in. 38.3 x 26.7 (single 72V battery)	-	38.3 x 20.1 (2x - 36V battery)
	66	Drive motor rating (60 min. rating)	kw	7.5		
	67	Hoist motor rating (25% duty cycle rating)	kw	2 x 15		
	68	Drive motor control		AC - MOSFET		
	69	Hoist motor control		AC - MOSFET		

RL = rated load, NL = no load

*Optional with Yale Power Key

NTA030SB - MEDIUM WHEEL BASE / NTA035SB - LONG WHEEL BASE & SHORT WHEEL BASE

2-STAGE TRI-FORM MAST DIMENSIONS - TYPICAL CONFIGURATIONS

Total lift height (top of forks)	Overall lowered height	Overall extended height	Main lift maximum fork height	Aux mast lift height (FL)	Operator orderpicking height	Operator platform height max
in. (mm)	in. (mm)	in. (mm)	in. (mm)	in. (mm)	in. (mm)	in. (mm)
232.3 (5900)	118.1 (3000)	271.1 (6887)	148.0 (3760)	84.3 (2140)	220 (5588)	160.8 (4085)
255.9 (6500)	129.5 (3290)	294.8 (7487)	171.6 (4360)	84.3 (2140)	244 (6198)	184.4 (4685)
279.5 (7100)	141.3 (3590)	318.4 (8087)	195.3 (4960)	84.3 (2140)	268 (6807)	208.1 (5285)
302.4 (7680)	141.3 (3590)	341.2 (8667)	195.3 (4960)	107.1 (2720)	268 (6807)	208.1 (5285)
302.1 (7700)	153.1 (3890)	342.0 (8687)	218.9 (5560)	84.3 (2140)	291 (7391)	231.7 (5885)
326.8 (8300)	164.9 (4190)	365.6 (9287)	242.5 (6160)	84.3 (2140)	315 (8001)	255.3 (6485)
337.0 (8560)	153.1 (3890)	375.9 (9547)	218.9 (5560)	118.1 (3000)	291 (7391)	231.7 (5885)
350.4 (8900)	176.8 (4490)	389.3 (9887)	266.1 (6760)	84.3 (2140)	339 (8611)	278.9 (7085)
360.6 (9160)	164.9 (4190)	399.5 (10147)	242.5 (6160)	118.1 (3000)	315 (8001)	255.3 (6485)
374.0 (9500)	188.6 (4790)	412.9 (10487)	289.8 (7360)	84.3 (2140)	362 (9195)	302.6 (7685)
381.9 (9700)	192.5 (4890)	420.7 (10687)	297.6 (7560)	84.3 (2140)	370 (9398)	310.4 (7885)
384.3 (9760)	176.8 (4490)	423.1 (10747)	266.1 (6760)	118.1 (3000)	339 (8611)	278.9 (7085)
396.9 (10080)	206.3 (5240)	435.7 (11067)	312.6 (7940)	84.3 (2140)	385 (9779)	325.4 (8265)
407.9 (10360)	188.6 (4790)	446.7 (11347)	289.8 (7360)	118.1 (3000)	362 (9195)	302.6 (7685)

MAST SIZES BELOW ARE ONLY AVAILABLE ON NTA030SB - LONG WHEEL BASE AND NTA035SB - SHORT WHEEL BASE

408.7 (10380)	212.2 (5390)	447.5 (11367)	324.4 (8240)	84.3 (2140)	397 (10084)	337.2 (8565)
415.7 (10560)	192.5 (4890)	454.6 (11547)	297.6 (7560)	118.1 (3000)	370 (9398)	310.4 (7885)
420.5 (10680)	218.1 (5540)	459.3 (11667)	336.2 (8540)	84.3 (2140)	409 (10389)	349.0 (8865)
430.7 (10940)	206.3 (5240)	469.6 (11927)	312.6 (7940)	118.1 (3000)	385 (9779)	325.4 (8265)
436.2 (11080)	226.0 (5740)	475.1 (12067)	352.0 (8940)	84.3 (2140)	424 (10770)	364.8 (9265)
442.5 (11240)	212.2 (5390)	481.4 (12227)	324.4 (8240)	118.1 (3000)	397 (10084)	337.2 (8565)
454.3 (11540)	218.1 (5540)	493.2 (12527)	336.2 (8540)	118.1 (3000)	409 (10389)	349.0 (8865)
455.9 (11580)	235.8 (5990)	494.8 (12567)	371.7 (9440)	84.3 (2140)	444 (11278)	384.4 (9765)
463.8 (11780)	239.8 (6090)	502.6 (12767)	379.5 (9640)	84.3 (2140)	452 (11481)	392.3 (9965)
470.0 (11940)	226.0 (5740)	508.9 (12927)	352.0 (8940)	118.1 (3000)	424 (10770)	364.8 (9265)
475.6 (12080)	245.7 (6240)	514.4 (13067)	391.3 (9940)	84.3 (2140)	464 (11786)	404.1 (10265)
489.8 (12440)	235.8 (5990)	528.6 (13427)	371.7 (9440)	118.1 (3000)	444 (11278)	384.4 (9765)
491.3 (12480)	253.5 (6440)	530.2 (13467)	407.1 (10340)	84.3 (2140)	479 (12167)	419.9 (10665)
497.6 (12640)	239.8 (6090)	536.5 (13627)	379.5 (9640)	118.1 (3000)	452 (11481)	392.3 (9965)
509.4 (12940)	245.7 (6240)	548.3 (13927)	391.3 (9940)	118.1 (3000)	464 (11786)	404.1 (10265)
525.2 (13340)	253.5 (6440)	564.1 (14327)	407.1 (10340)	118.1 (3000)	479 (12167)	419.9 (10665)

If additional "total lift" or "operator pick height" is required for your application, contact your local Yale® dealer for assistance.

NTA035SB - MEDIUM WHEEL BASE / LONG WHEEL BASE

2-STAGE QUAD-FORM MAST DIMENSIONS - TYPICAL CONFIGURATIONS

Total lift height (top of forks)	Overall lowered height	Overall extended height	Main lift maximum fork height	Aux mast lift height (FL)	Operator orderpicking height	Operator platform height max
in. (mm)	in. (mm)	in. (mm)	in. (mm)	in. (mm)	in. (mm)	in. (mm)
219.7 (5580)	118.1 (3000)	258.5 (6567)	135.4 (3440)	84.3 (2140)	208 (5283)	148.2 (3765)
239.4 (6080)	127.6 (3240)	278.2 (7067)	155.1 (3940)	84.3 (2140)	227 (5766)	167.9 (4265)
259.1 (6580)	137.4 (3490)	297.9 (7567)	174.8 (4440)	84.3 (2140)	247 (6274)	187.6 (4765)
281.9 (7160)	141.1 (3585)	320.7 (8147)	174.8 (4440)	107.1 (2720)	247 (6274)	187.6 (4765)
301.6 (7660)	147.2 (3740)	340.4 (8647)	194.5 (4940)	107.1 (2720)	267 (6782)	207.3 (5265)
318.1 (8080)	166.9 (4240)	357.0 (9067)	233.9 (5940)	84.3 (2140)	306 (7772)	246.7 (6265)
332.3 (8440)	157.1 (3990)	371.1 (9427)	214.2 (5440)	118.1 (3000)	287 (7290)	227.0 (5765)
340.9 (8660)	166.9 (4240)	397.8 (9647)	233.9 (5940)	107.1 (2720)	306 (7772)	246.7 (6265)
360.6 (9160)	176.8 (4490)	399.5 (10147)	253.5 (6440)	107.1 (2720)	326 (8280)	266.3 (6765)
371.7 (9440)	176.8 (4490)	410.5 (10427)	253.5 (6440)	118.1 (3000)	326 (8280)	266.3 (6765)
380.3 (9660)	186.6 (4740)	419.2 (10647)	273.2 (6940)	107.1 (2720)	346 (8788)	286.0 (7265)
391.3 (9940)	186.6 (4740)	430.2 (10927)	273.2 (6940)	118.1 (3000)	346 (8788)	286.0 (7265)
400.0 (10160)	196.5 (4990)	439.9 (11147)	292.9 (7740)	107.1 (2720)	365 (9271)	305.7 (7765)
408.7 (10380)	212.2 (5390)	447.5 (11367)	324.4 (8240)	84.3 (2140)	397 (10084)	337.2 (8565)
411.0 (10440)	196.5 (4990)	449.9 (11427)	292.9 (7740)	118.1 (3000)	365 (9271)	305.7 (7765)
419.7 (10660)	206.3 (5240)	458.5 (11647)	312.6 (7940)	107.1 (2720)	385 (9779)	325.4 (8265)
431.5 (10960)	212.2 (5390)	470.4 (11947)	324.4 (8240)	107.1 (2720)	397 (10084)	337.2 (8565)
442.5 (11240)	212.2 (5390)	481.4 (12227)	324.4 (8240)	118.1 (3000)	397 (10084)	337.2 (8565)
459.1 (11660)	226.0 (5740)	497.9 (12647)	352.0 (8940)	107.1 (2720)	424 (10770)	364.8 (9265)
470.1 (11940)	226.0 (5740)	508.9 (12927)	352.0 (8940)	118.1 (3000)	424 (10770)	364.8 (9265)
478.7 (12160)	235.8 (5990)	517.6 (13147)	371.6 (9440)	107.1 (2720)	444 (11278)	384.4 (9765)
489.8 (12440)	235.8 (5990)	528.6 (13427)	371.6 (9440)	118.1 (3000)	444 (11278)	384.4 (9765)
509.4 (12940)	245.7 (6240)	548.3 (13927)	391.3 (9940)	118.1 (3000)	464 (11786)	404.1 (10265)

MASTS BELOW ARE AVAILABLE ON NTA035SB - LONG WHEEL BASE ONLY

514.2 (13060)	253.5 (6440)	553.0 (14047)	407.1 (10340)	107.1 (2720)	479 (12167)	419.9 (10665)
525.2 (13340)	253.5 (6440)	564.1 (14327)	407.1 (10340)	118.1 (3000)	479 (12167)	419.9 (10665)

If additional "total lift" or "operator pick height" is required for your application, contact your local Yale dealer for assistance.

NTA030SB - MEDIUM WHEEL BASE, NTA030SB / NTA035SB - LONG WHEEL BASE & SHORT WHEEL BASE

3-STAGE TRI-FORM MAST DIMENSIONS - TYPICAL CONFIGURATIONS

Total lift height (top of forks)	Overall lowered height	Overall extended height	Main lift maximum fork height	Aux mast lift height (FL)	Operator orderpicking height	Operator platform height max
in. (mm)	in. (mm)	in. (mm)	in. (mm)	in. (mm)	in. (mm)	in. (mm)
227.9 (5790)	118.1 (3000)	266.8 (6777)	143.7 (3650)	84.3 (2140)	216 (5486)	156.5 (3975)
250.8 (6370)	141.1 (3585)	289.6 (7357)	143.7 (3650)	107.1 (2720)	216 (5486)	156.5 (3975)
280.3 (7120)	141.1 (3585)	319.2 (8107)	173.2 (4400)	107.1 (2720)	246 (6248)	186.0 (4725)
320.9 (8150)	152.2 (3865)	359.7 (9137)	202.8 (5150)	118.1 (3000)	275 (6985)	215.6 (5475)
350.4 (8900)	152.2 (3865)	389.3 (9887)	232.3 (5900)	118.1 (3000)	305 (7747)	245.1 (6225)
368.9 (9370)	141.1 (3585)	407.8 (10357)	261.8 (6650)	107.1 (2720)	334 (8484)	274.6 (6975)
375.6 (9540)	147.2 (3740)	414.4 (10527)	291.3 (7400)	84.3 (2140)	364 (9246)	304.1 (7725)
405.1 (10290)	157.1 (3990)	444.0 (11277)	320.9 (8150)	84.3 (2140)	393 (9982)	333.7 (8475)
409.5 (10400)	152.2 (3865)	448.3 (11387)	291.3 (7400)	118.1 (3000)	364 (9246)	304.1 (7725)
MAST SIZES BELOW ARE ONLY AVAILABLE ON NTA030SB - LONG WHEEL BASE AND NTA035SB - SHORT WHEEL BASE						
434.6 (11040)	166.9 (4240)	473.5 (12027)	350.4 (8900)	84.3 (2140)	423 (10744)	363.2 (9225)
439.0 (11150)	157.1 (3990)	477.8 (12137)	320.9 (8150)	118.1 (3000)	393 (9982)	333.7 (8475)
464.2 (11790)	176.8 (4490)	503.0 (12777)	379.9 (9650)	84.3 (2140)	452 (11481)	392.7 (9975)
468.5 (11900)	166.9 (4240)	507.4 (12887)	350.4 (8900)	118.1 (3000)	423 (10744)	363.2 (9225)
493.7 (12540)	186.6 (4740)	532.6 (13527)	409.4 (10400)	84.3 (2140)	482 (12243)	422.2 (10725)
498.0 (12650)	176.8 (4490)	536.9 (13637)	379.9 (9650)	118.1 (3000)	452 (11481)	392.7 (9975)

If additional "total lift" or "operator pick height" is required for your application, contact your local Yale dealer for assistance.

NTA035SB - MEDIUM WHEEL BASE / LONG WHEEL BASE

3-STAGE QUAD-FORM MAST DIMENSIONS - TYPICAL CONFIGURATIONS

Total lift height (top of forks)	Overall lowered height	Overall extended height	Main lift maximum fork height	Aux mast lift height (FL)	Operator orderpicking height	Operator platform height max
in. (mm)	in. (mm)	in. (mm)	in. (mm)	in. (mm)	in. (mm)	in. (mm)
279.9 (7110)	118.1 (3000)	318.8 (8097)	195.7 (4970)	84.3 (2140)	268 (6807)	208.5 (5295)
309.4 (7860)	127.6 (3240)	348.3 (8847)	225.2 (5720)	84.3 (2140)	298 (7569)	238.0 (6045)
313.8 (7970)	152.2 (3865)	352.6 (8957)	195.7 (4970)	118.1 (3000)	268 (6807)	208.5 (5295)
332.3 (8440)	141.1 (3585)	371.1 (9427)	225.2 (5720)	107.1 (2720)	298 (7569)	238.0 (6045)
343.3 (8720)	152.2 (3865)	382.2 (9707)	225.2 (5720)	118.1 (3000)	298 (7569)	238.0 (6045)
361.8 (9190)	141.1 (3585)	400.7 (10177)	254.7 (6470)	107.1 (2720)	327 (8306)	267.5 (6795)
372.8 (9470)	152.2 (3865)	411.7 (10457)	254.7 (6470)	118.1 (3000)	327 (8306)	267.5 (6795)
391.3 (9940)	147.2 (3740)	430.2 (10927)	284.3 (7220)	107.1 (2720)	357 (9068)	297.0 (7545)
402.4 (10220)	152.2 (3865)	441.2 (11207)	284.3 (7220)	118.1 (3000)	357 (9068)	297.0 (7545)
420.9 (10690)	157.1 (3990)	459.7 (11677)	313.8 (7970)	107.1 (2720)	386 (9804)	326.6 (8295)
427.6 (10860)	166.9 (4240)	466.4 (11847)	343.3 (8720)	84.3 (2140)	416 (10566)	356.1 (9045)
431.9 (10970)	157.1 (3990)	470.7 (11957)	313.8 (7970)	118.1 (3000)	386 (9804)	326.6 (8295)
450.4 (11440)	166.9 (4240)	489.3 (12427)	343.3 (8720)	107.1 (2720)	416 (10566)	356.1 (9045)
461.4 (11720)	166.9 (4240)	500.3 (12707)	343.3 (8720)	118.1 (3000)	416 (10566)	356.1 (9045)
479.9 (12190)	176.8 (4490)	518.8 (13177)	372.8 (9470)	107.1 (2720)	445 (11303)	385.6 (9795)
490.9 (12470)	176.8 (4490)	529.8 (13457)	372.8 (9470)	118.1 (3000)	445 (11303)	385.6 (9795)
509.4 (12940)	186.6 (4740)	548.3 (13927)	402.4 (10220)	107.1 (2720)	475 (12065)	415.2 (10545)
516.1 (13110)	196.5 (4990)	555.0 (14097)	431.9 (10970)	84.3 (2140)	504 (12802)	444.7 (11295)
520.5 (13220)	186.6 (4740)	559.3 (14207)	402.4 (10220)	118.1 (3000)	475 (12065)	415.2 (10545)
539.0 (13690)	196.5 (4990)	577.8 (14677)	431.9 (10970)	107.1 (2720)	504 (12802)	444.7 (11295)
545.7 (13860)	206.3 (5240)	584.5 (14847)	461.4 (11720)	84.3 (2140)	534 (13564)	474.2 (12045)
550.0 (13970)	196.5 (4990)	588.9 (14957)	431.9 (10970)	118.1 (3000)	504 (12802)	444.7 (11295)

MAST BELOW ARE AVAILABLE ONLY ON NTA035SB - LONG WHEEL BASE

568.5 (14440)	206.3 (5240)	607.4 (15427)	461.4 (11720)	107.1 (2720)	534 (13564)	474.2 (12045)
579.5 (14720)	206.3 (5240)	618.4 (15707)	461.4 (11720)	118.1 (3000)	534 (13564)	474.2 (12045)

MASTS BELOW ARE SPECIAL ORDER WITH NTA035SB - LONG WHEEL BASE ONLY - DIMENSIONS ARE APPROXIMATELY (INCHES)

581	219	620	496	84	569	509
591	211	631	473	118	546	486
603	215	642	485	118	558	498
615	222	655	508	107	581	521
627	226	667	520	107	593	533
634	236	674	549	84	622	562
651	234	690	544	107	617	557
668	236	707	549	118	622	562

If additional "total lift" or "operator pick height" is required for your application, contact your local Yale dealer for assistance.

FEATURES LIST - NTA030-035SB

PERFORMANCE	STD	OPT
AC hoist system with regenerative lowering	●	
Auto deceleration system (ADS)	●	
Operator adjustable performance modes (soft, standard, medium, hard)	●	
End of aisle slow down		●
End of aisle slow down to stop		●
End of aisle stop		●
Wire guidance - 5.25 kHz line frequency		●
Wire guidance - 6.25 kHz line frequency		●
DRIVE	STD	OPT
15.7" x 6.2" Polyurethane drive wheel	●	
13.8" x 5.5" Polyurethane load wheels	●	
LIFT	STD	OPT
2 stage tri form construction mast 232" maximum lift height, 119" overall lowered height	●	
3 Stage tri form construction masts		●
2 Stage quad form construction masts (3,500 lbs. model)		●
3 Stage quad form construction masts (3,500 lbs. model)		●
HANDLING	STD	OPT
28" carriage with 26" rotator	●	
1.75" x 4" x 42" Pin type standard taper forks	●	
1.50" x 5" x 42" Pin type standard taper forks		●
1.75" x 4" x 32" Pin type standard taper forks		●
1.75" x 4" x 40" Pin type standard taper forks		●
1.75" x 4" x 47" Pin type standard taper forks		●
Adjustable mechanical stabilizers		●
Fixed narrow mechanical stabilizers		●
Guide rollers (adds 2" to chassis width)		●
ERGONOMICS	STD	OPT
Rotating seat with auto centering & locking position	●	
Seat side controls	●	
Multi-turn steering	●	
Sit, stand or lean operator positions	●	
Flip-up side rails with gas spring assist and interlock	●	
Flip-up full-suspension cloth seat with height adjustment	●	
Adjustable armrests independent of seat position	●	
Anti-fatigue floor mat - ribbed rubber	●	
Operator fan & dome light - ohg mounted	●	
Forward mounted controls		●
Return to center steering		●
OPERATION	STD	OPT
44.2" x 20.8" x 30.9" Battery compartment	●	
Medium wheel base	●	
38.3" x 26.7" x 30.9" Battery compartment (3,500 lbs. model)	●	
Short wheel base (3,500 lbs. model)	●	
Key switch start	●	
55" Operator platform width	●	
Retractable tether with full body harness	●	
56" Chassis width	●	
24V DC/DC converter (2 amp)	●	
Without battery	●	
Without charger	●	
Fully integrated canbus control system	●	
Parking brake with foot switch release	●	
Graphics display with real time truck status	●	
Battery discharge indicator with lift interrupt	●	
Integral multi-mode hour meter	●	
Real-time onboard diagnostics	●	
Active thermal management system	●	
Override for forks traverse (in MDU compartment)	●	
Manual lowering valve (in MDU compartment)	●	
Battery top access door	●	
Static discharge strap	●	
Electronic horn	●	
Power supply disconnect button	●	
One piece motor compartment cover with gas cylinder assist	●	
Welded steel frame	●	
38.4" x 26.8" x 30.9" Battery compartment	●	
38.7" x 23.6" x 30.9" Battery compartment		●

OPERATION CONTINUED	STD	OPT
38.7" x 23.8" x 30.9" Battery compartment		●
38.7" x 27.0" x 30.9" Battery compartment		●
37.9" x 14.0" x 30.9" Battery compartment (3,500 lbs. model)		●
38.1" x 15.8" x 30.9" Battery compartment (3,500 lbs. model)		●
38.3" x 13.5" x 30.9" Battery compartment (3,500 lbs. model)		●
38.3" x 17.9" x 30.9" Battery compartment (3,500 lbs. model)		●
38.3" x 20.1" x 30.9" Battery compartment (3,500 lbs. model)		●
38.7" x 20.4" x 30.9" Battery compartment (3,500 lbs. model)		●
38.3" x 15.7" x 30.5" Battery compartment (3,500 lbs. model)		●
Long wheel base		●
Medium wheel base (3,500 lbs. model)		●
Key switch start with operator password		●
Clip board		●
Hydraulic stabilizers		●
Lexan windshield		●
RF terminal bracket		●
Trash bin & beverage holder		●
47" Operator platform width		●
61" Operator platform width		●
67" Operator platform width		●
Front barrier on operator platform		●
48" Chassis width		●
62" Chassis width		●
68" Chassis width		●
Yale Vision wireless access HID prox card reader		●
Yale Vision wireless access iClass MiFare prox card reader		●
Yale Vision wireless access ISO prox card reader		●
Yale Vision wireless monitoring with cellular connectivity		●
Yale Vision wireless monitoring with WIFI connectivity		●
Yale Vision wireless verification		●
Yale Reliant™		●
Audible alarm - reverse direction activated - self-adjusting 82-102 dB(A)		●
Motion alarm - forward and reverse operation - self-adjusting 82-102 dB(A)		●
12V DC/DC converter (2.4 amp)		●
24V DC/DC converter (2 amp)		●
Installation assistance package		●
RFID control system		●
APPEARANCE	STD	OPT
2-Part poly YALE gold paint	●	
CONSTRUCTION	STD	OPT
UL classification type "E"	●	
Cold store construction (-40° F)		●
UL classification type "EE" - includes UL label		●
VISIBILITY	STD	OPT
Amber LED strobe light, continuous operation with key on	●	
Work lights - right and left side	●	
Flashing amber strobe on motor cover and under operator compartment	●	
Wire mesh installed on top of operator compartment		●
Lexan overhead guard cover		●
Blue and red spot lights		●
ENERGY SYSTEM	STD	OPT
Lead acid	●	
Yale Power Key		●
SUPPLEMENTAL	STD	OPT
English literature pack and labels	●	
Operator's, parts and service manual	●	
12 Months / no hour limit full truck warranty, 36 months / 6,000 hours powertrain warranty, 60 months / 10,000 hour frame warranty	●	
Stabilizer label		●
French literature pack and labels		●
Spanish literature pack and labels		●
Multiple extended protection plans (contact warranty department for details)		●

About Yale



Yale Lift Truck Technologies leverages over a century of material handling experience and substantial investment in innovation to bring the most advanced technology-driven lift truck solutions to market. The company offers a full line of award-winning lift trucks, including reach trucks, order pickers, turret trucks, pallet jacks and trucks, pallet stackers, tow tractors and counterbalanced forklifts, as well as powerful operator assist solutions, proven robotics and a wide range of power sources to help customers adapt to today's demanding supply chain. Yale and its independent dealer network support these solutions with comprehensive after-sales service, parts, financing and training.

MATERIALS HANDLING FOR:

Third-party logistics (3PL)

Auto parts distribution

Beverage

Cold & frozen foods

Food distribution

Food processing

Furniture & furnishings

Government

Health & pharma

Home centers & durables

Retail & e-commerce

Yale Lift Truck Technologies
P.O. Box 7367
Greenville, NC 27835-7367
U.S.A.

yale.com



EXPLORE MORE
ONLINE.
←

© 2024 Hyster-Yale Group, Inc., all rights reserved. YALE and  are trademarks of Hyster-Yale Group, Inc.

Trucks may be shown with optional equipment and/or features not available in all regions. Truck performance may be affected by the condition of the vehicle, how it is equipped and the application. Specifications are subject to change without notice. Consult your Yale® Dealer if any of the information shown is critical to your application.

CERTIFICATION: Yale lift trucks meet the design and construction requirements of B56.1-1969, per OSHA Section 1910.178(a)(2), and also comply with the B56.1 revision in effect at time of manufacture. Classified by Underwriters' Laboratories, Inc.